

Introduction Objective

The exercises of Structural Design III deepen the understanding of the relationship between force, form and material with the help of graphic statics. These exercises illustrate the design process of a structure built from one of the main building materials: steel, reinforced concrete, timber and masonry. We will look at the following design steps: brief discussion of the concept, calculation of the relevant loads, global equilibrium, internal force flow, variations of typology-topology-geometry, design for both vertical and horizontal loads and material properties.

For further reading, following literature is recommended:

- Skript «Tragwerksentwurf III-IV», Pages 57 - 64: Erläuterungen zum Konstruieren in Mauerwerk
- Skript «Tragwerksentwurf III-IV», Pages 115 - 124: Erläuterungen zur dreidimensionalen Raumbildung in Mauerwerk
- Skript zu «Tragwerksentwurf III-IV», Pages 185 - 195: Materialanhang zum Baustahl
- Faustformel, Pages 88 - 91: Erläuterungen zum Werkstoff Mauerwerk
- Faustformel, Page 167: Erläuterungen zum Kräfteverlauf in Gewölben

Architectonical conditions

You want to design a chapel using masonry. It should be built as a composition of identical modules that are statically independent. In this exercise, we are dealing with the design of one module with a groundfloor covering an area of 10 by 5 meters. The inner space should have a height of at least 3 meters.

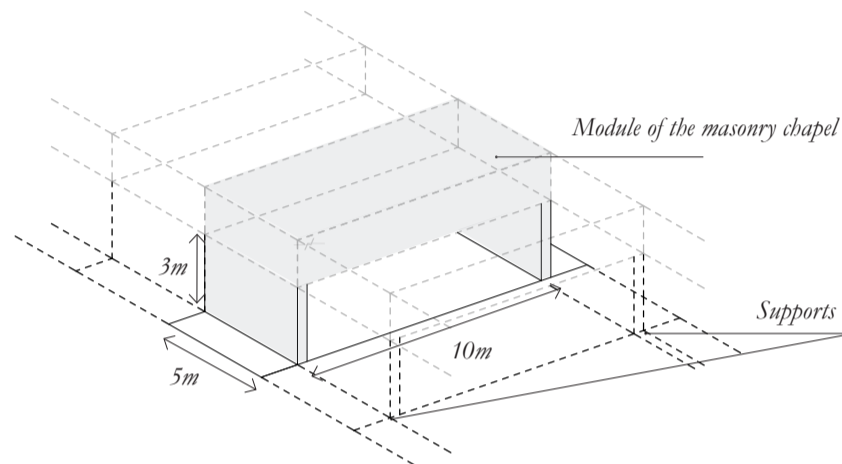

Form and force

The design process begins studying several possible structural schemes in masonry. Analyze the relationship between force and form. Show a possible force flow for both loading conditions: evenly distributed force (row 1) and asymmetrical loading condition (row 2).

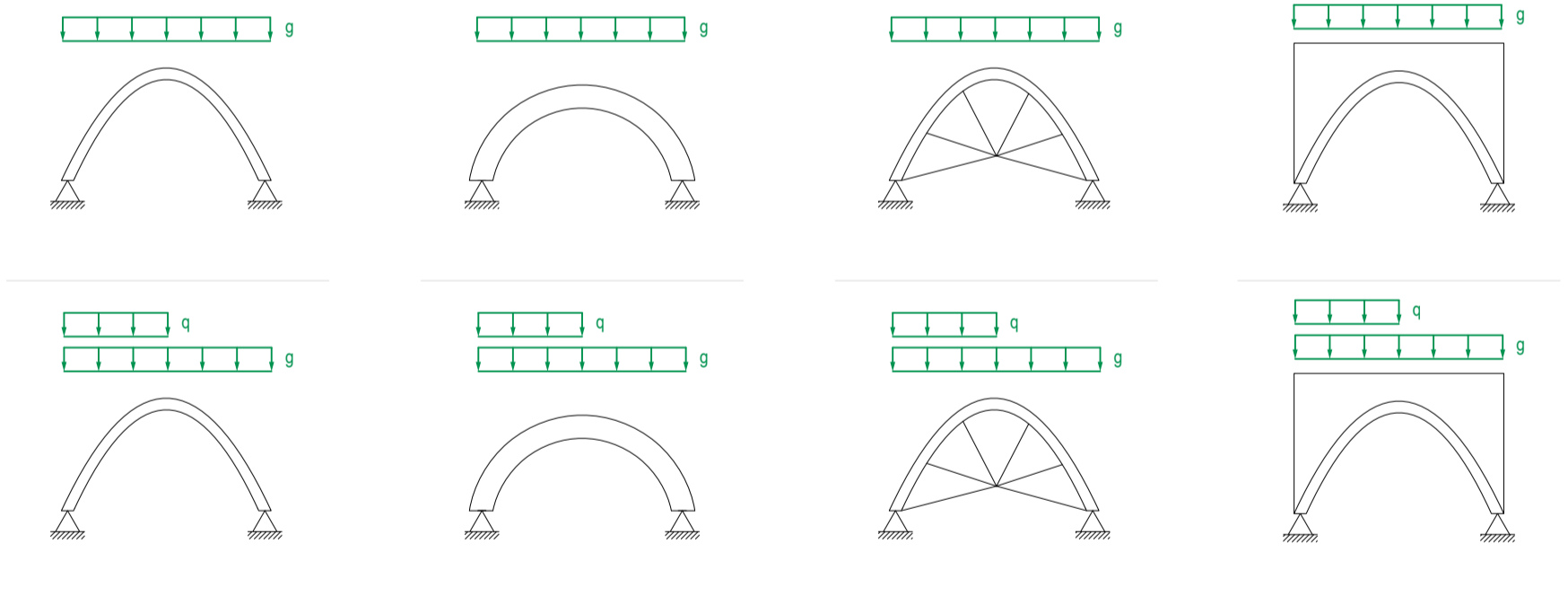

Idea for the structural design

It is decided to install a vault resting on two supporting walls. In the following exercises you will look at different variations that deal with the horizontal thrust.

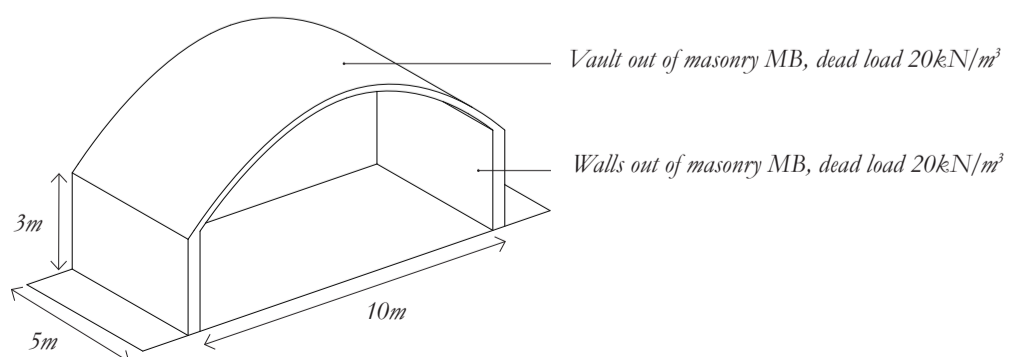

Task 1 Transfer of vertical loads: design variation 1

Structure equilibrating the horizontal thrust by means of tension cables

Axonometry

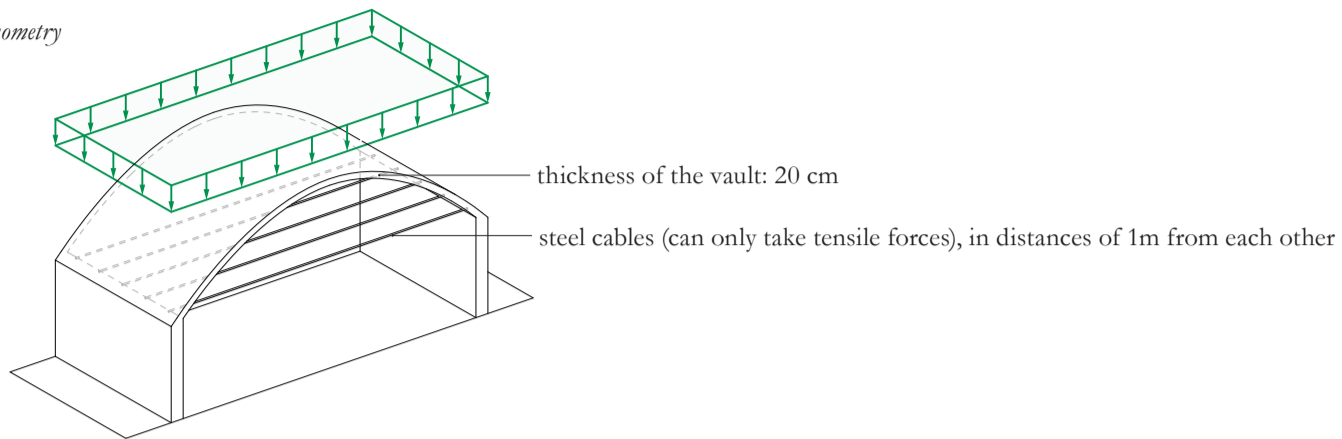

1a Determination of the internal forces

In order to determine the internal forces within the structure, we will first calculate the external loads. At this stage of the design, we will only consider the self-weight. All other external loads can be neglected. Also, for simplification, the archlength of the vault can be set equal to its span. Draw a possible force flow and determine the magnitude of the inner forces as well as the support forces in the drawings below with the help of a force-diagram. Use the colours red for tension, blue for compression and green for the external forces.

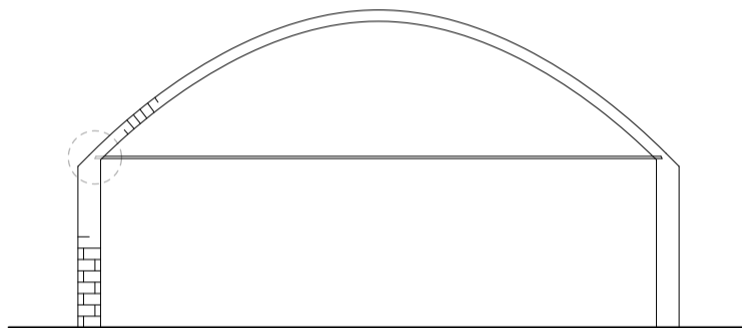

Elevation (1:100)

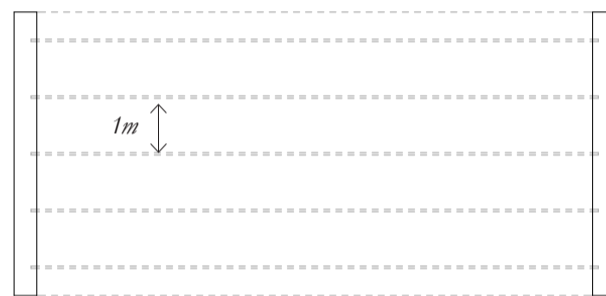

Floorplan (1:100)

Force diagramm (1cm:10kN)

1b Relations between form, force and material

Hint:
«Skript TE
3-4» S.191
Knickdiagramm,
«Skript TE
3-4» S.190
Materialkennwerte,
Anhang
«Formelsammlung»

Evaluate if there is buckling risk in the wall by using the results of task 1a. The walls have hinge-support on both ends. The thickness (t) of the wall is 40 cm. And the force excentricity (e) is 10cm.

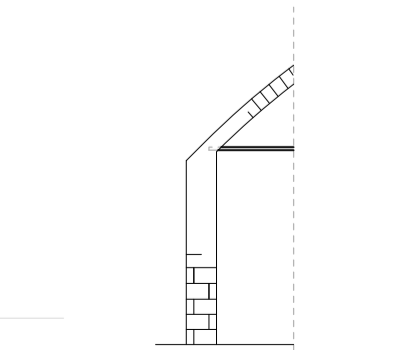
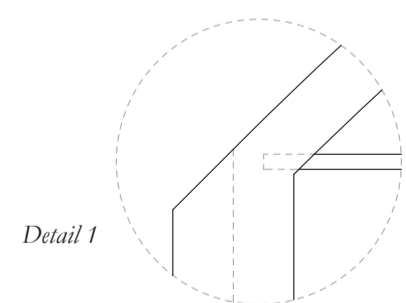
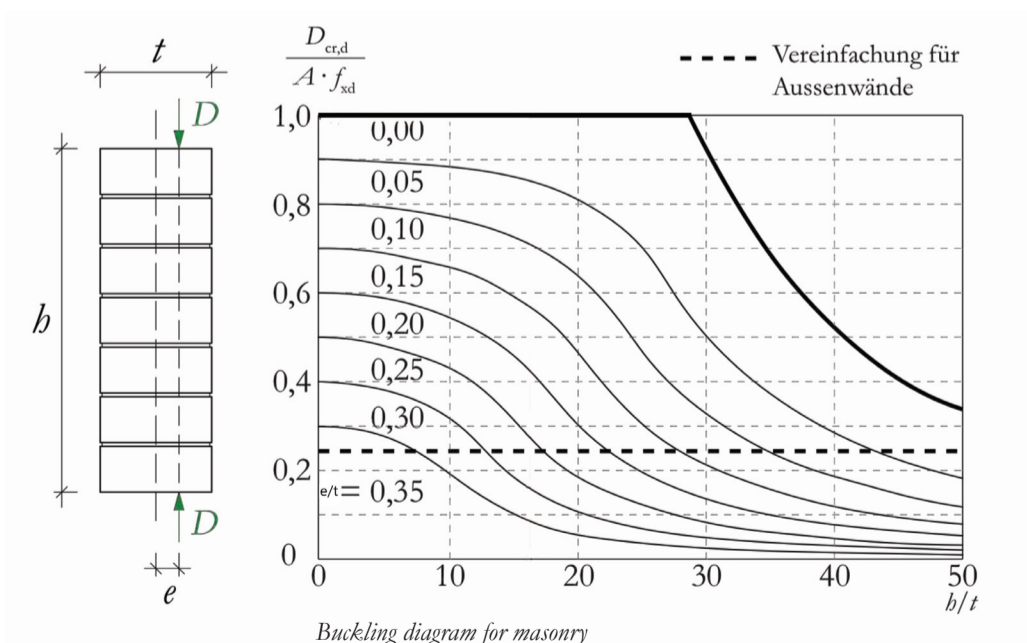

Can the walls resist a horizontal load applied in the center of the wall without any additional structural elements?

Task 2 Transfer of vertical loads: design variation 2

Structure redirecting the horizontal thrust by means additional weight and buttresses

In order to create a fully open space, you want to avoid the use of horizontal tension cables in the inside. Instead, additional weight and buttresses will be used to redirect the horizontal thrust into the ground.

Axonometry

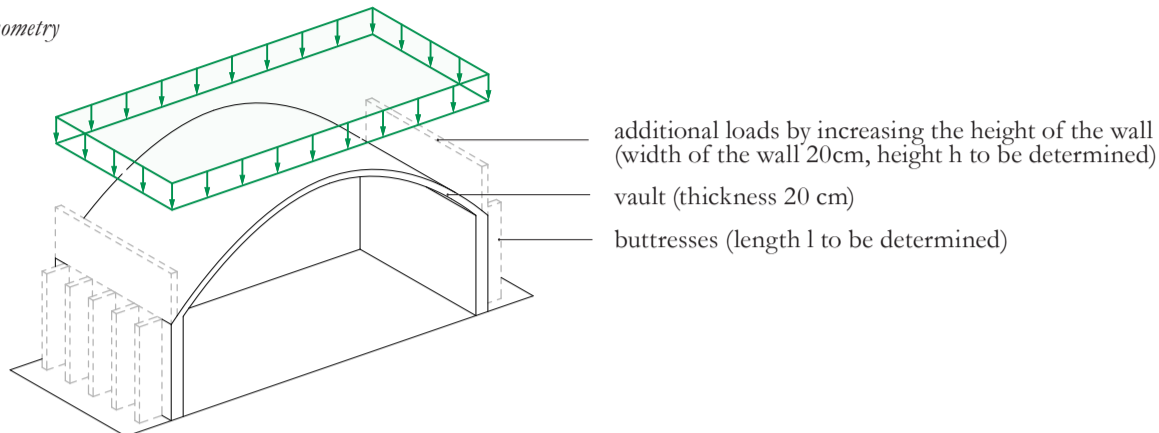

2a Determination of the height of the wall and length of the buttresses

In this variant the vault has no cables but instead it has two thin walls at the extremes and also buttresses. You can use the same self-weight for the vault that you calculated in 1a. Determine, by using the force diagram, the minimal height h and the minimal length l which have to be added in order to deviate the present forces. Assume that the structure cannot take tension forces. Use the colour red for tension, blue for compression and green for the external forces. Take into account that the compression forces in masonry cannot exceed an angle of 30 degrees from to the vertical.

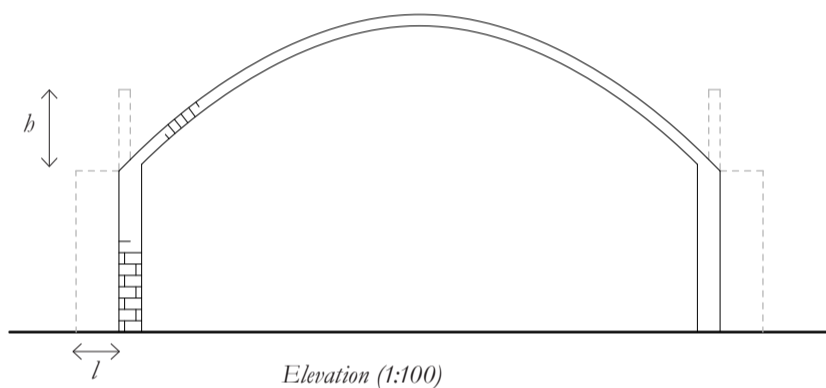

Necessary length l

Minimal height h

2b Question on the relations between form, force and material

Help:
 «Skript TE 3-4» S.190
 →
 Materialkennwerte,
 «Skript TE 3-4»
 S.196-197

Calculate the required thickness of the buttresses. Consider that the buttresses are built using masonry and the joints are filled with mortar, which means that its strength can be increased by a factor of 1.5. Assume that the force spreads over a width of 0.1 m.

What would be the influence on the buttress length (l) if a horizontal point load is applied in the middle of the buttress?

Force diagram (1cm:10kN)

