

Introduction Objective

The exercises of Structural Design III deepen the understanding of the relationship between force, form and material with the help of graphic statics. These exercises illustrate the design process of a structure built from one of the main building materials: steel, reinforced concrete, timber and masonry. We will look at the following steps: brief discussion of the concept, calculation of the relevant loads, global equilibrium, internal force flow, variations of typology-topology-geometry, design for both vertical and horizontal loads and dimensioning.

For further reading, following literature is recommended:

- Script «Tragwerksentwurf III-IV», Page 27 - 40: Erläuterungen zum Konstruieren in Stahl
- Script «Tragwerksentwurf III-IV», Page 95 - 107: Erläuterungen zur dreidimensionalen Raumbildung in Stahl
- Script «Tragwerksentwurf III-IV», Page 155 - 163: Materialanhang zum Baustahl
- Faustformel, Page 75 - 79: Erläuterungen zum Werkstoff Stahl
- Faustformel, Page 131 - 133: Erläuterungen zum Kräfteverlauf in Scheiben mit Öffnungen

Architectural conditions

The following architectural conditions are given: A space for a Café is designed above the 8*8 meter platform. To be usable as a covered area for the customers, the room is situated 4 meters over the platform. In the corner of this platform there are 3 steps, preventing the building to have a column there. The final project should rest on columns on the other 3 corners.

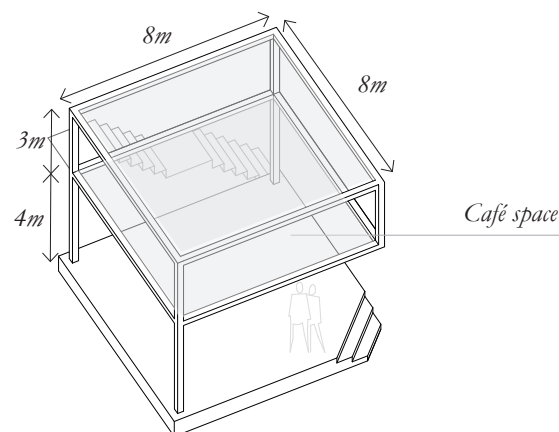

Console girder possibilities

Consider different possibilities how the structure of the Café could be composed. Discuss how the variants of the continuous girder, Vierendel girder and truss, shown in the sketches below, influence the weight as well as the spatial and architectural qualities of the structure.

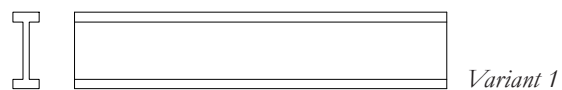

Variant 1

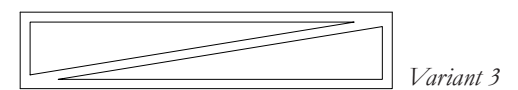

Variant 3

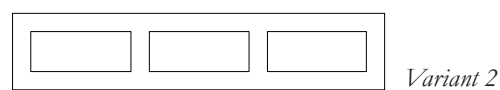

Variant 2

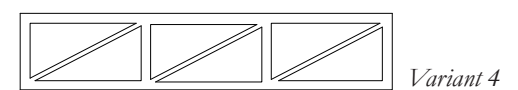

Variant 4

Idea for the structural design

You decide to use steel trusses and reinforced concrete slabs (25cm) for the structure. In the following tasks you will analyse different design variants considering this choice. But, before that, calculate the loads of the building and distribute them to the four corners as shown in the drawing below.

Hint 1: Consider the dead loads of both the concrete slab and the steel beam.

Hint 2: To calculate the weight of the steel beams, consider the slenderness (Script TWE II, Table 14).

Hint 3: Find the value of the live load in eQUILIBRIUM/courses/Structural Design III/Lasten und Kennwerte.

Hint 4: Note that the value for the snow load in the city of Zurich is 1.2 kN/m².

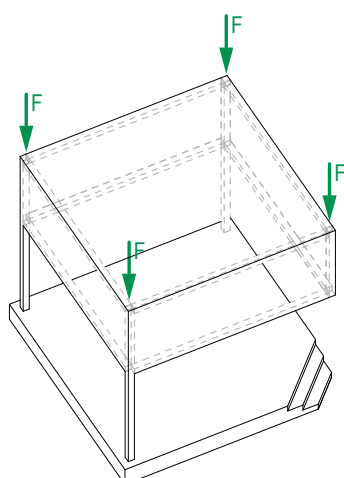

Task 1 Transfer of vertical loads: design variation 1

The structure is designed as a three-dimensional cantilevering truss.

1a Global equilibrium & qualitative forceflow

The following axonometric drawing shows a possible structure for carrying the vertical loads calculated in the last page (440 kN on each corner). Draw a possible internal force-flow and determine with the help of force diagrams the magnitude of the forces in the structural members as well as in the supports for the indicated load case. Use the colours red for tension, blue for compression and green for the support forces.

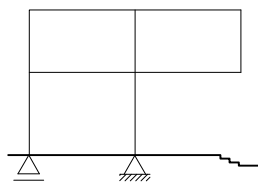
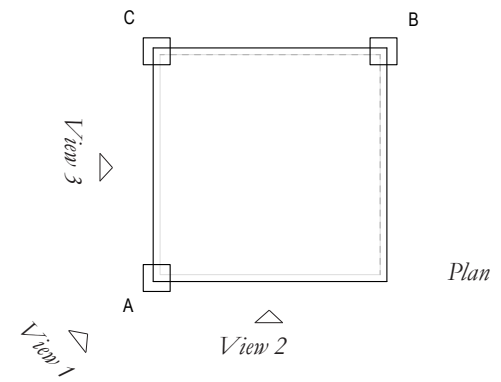
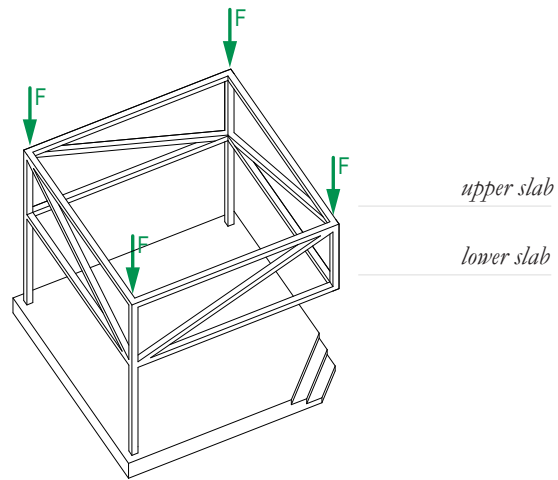

View 1

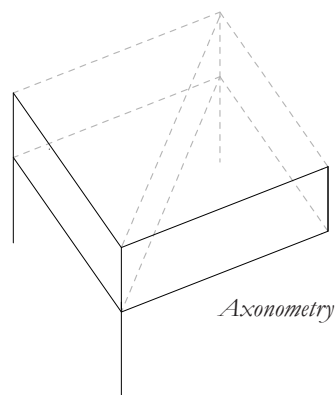

Axonometry

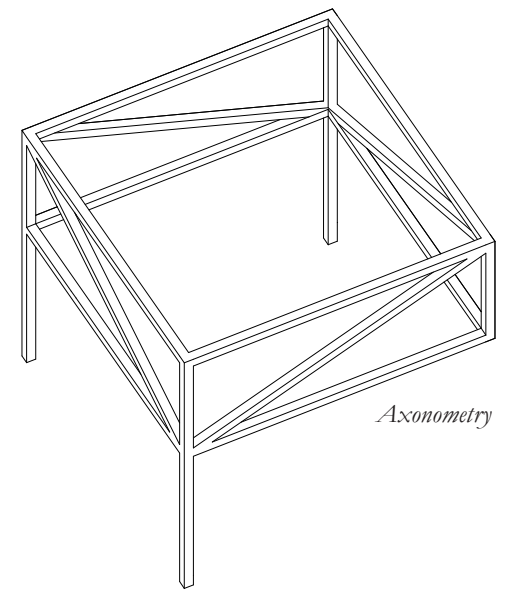

Axonometry

1b Quantitative forceflow

Force-diagram (1cm:100kN)

View 3

View 2

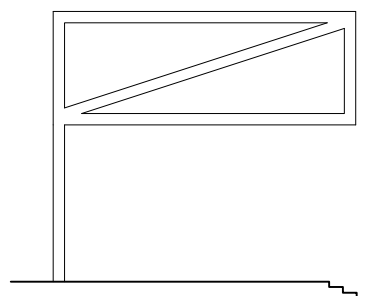
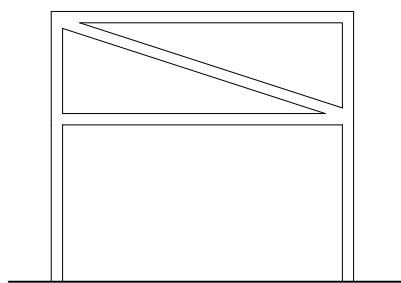

Floor plan (upper slab)

Floor plan (lower slab)

Force-diagram (1cm:200kN)

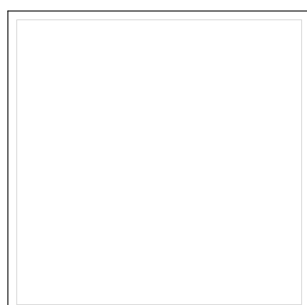
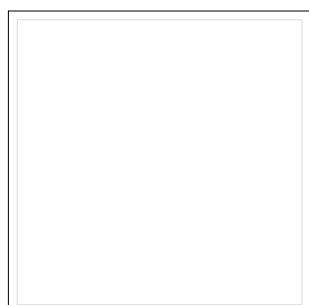

Task 2 Transfer of vertical loads: design variation 2

The structure is designed as a three-dimensional cantilevering truss

2a Global equilibrium & qualitative forceflow

Besides the changed arrangement of the diagonals, some mechanical installations need to be placed on the rooftop, above the missing column. These installations will apply a punctual load of 160 kN on this corner, which influences the behaviour of the structure. Draw a possible internal force-flow and determine with the help of force diagrams the magnitude of the forces in the structural members as well as in the supports for the indicated load case. Use the colours red for tension, blue for compression and green for the support forces.

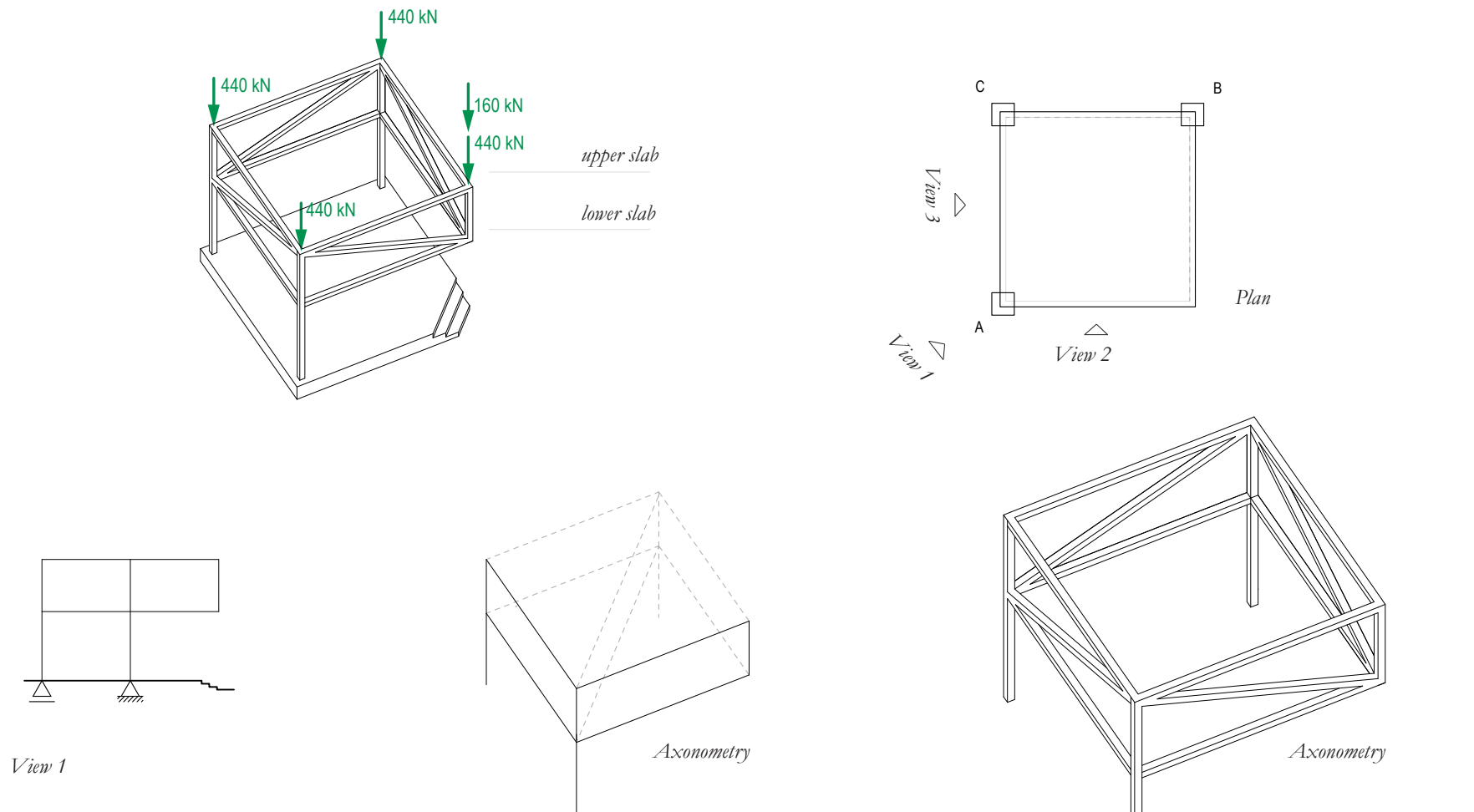

2b Quantitative forceflow

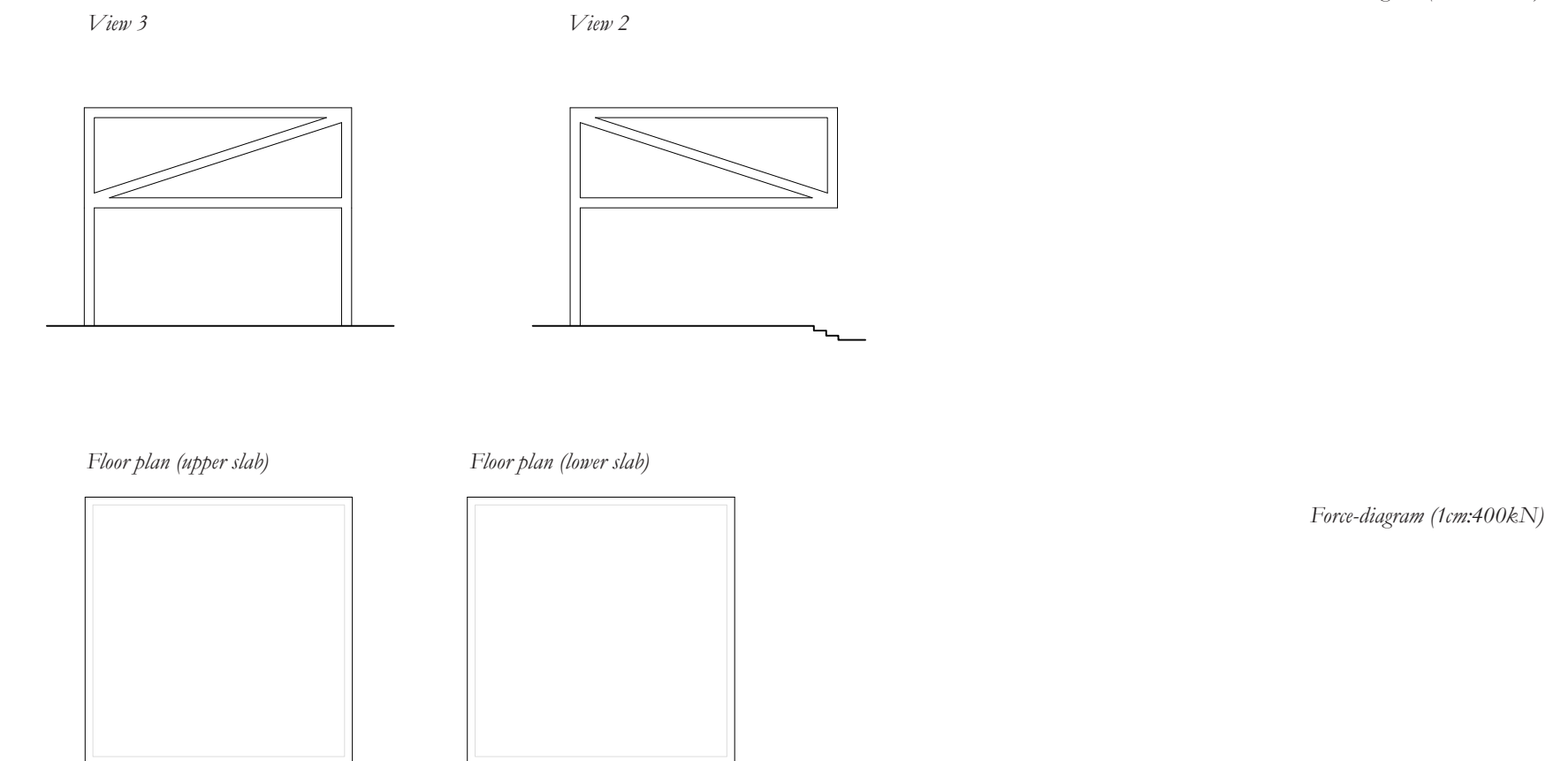

2c Dimensioning of elements

Determine the cross-sectional area of the diagonal tension elements. Determine with the help of the table (*Equilibrium Website/ Stahlprofile/ Seite 9/9 (ROR)*) appropriate pipe cross-sections (Steel: S 235)

Task 3 Determination of the internal forces in the structure under horizontal forces

3a Quantitative analysis of forceflow in lower slab

Discuss the stability of the structure under the influence of horizontal forces in the lower slab, draw a possible force-flow and calculate the internal forces using the force diagram. The axonometry below shows a possible bracing solution in order to guarantee the stability of the structure under the influence of horizontal forces acting in the lower slab. Use the colours red for tension, blue for compression and green for the support forces.

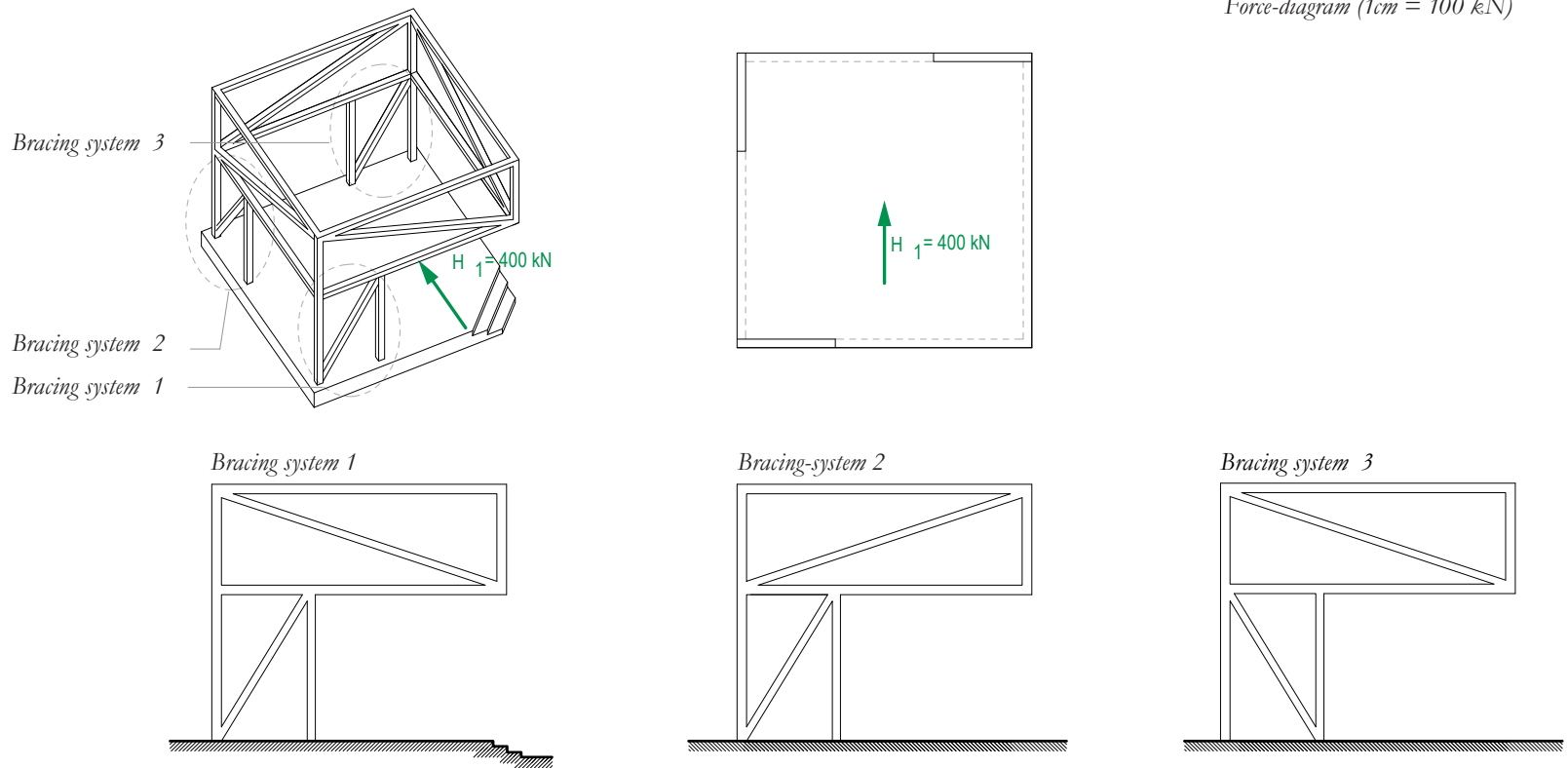

3b Quantitative analysis of forceflow in upper slab

Discuss the stability of the structure under the influence of horizontal forces in the upper slab, draw a possible force-flow and calculate the internal forces using the force diagram. The axonometry below shows a possible bracing solution in order to guarantee the stability of the structure under the influence of horizontal forces acting in the upper slab. Use the colours red for tension, blue for compression and green for the support forces.

