

Tragwerksentwurf I

Structural Design I

Philippe Block · Joseph Schwartz



Tragwerksentwurf
Structural Design



1. Gleichgewicht
1. Equilibrium

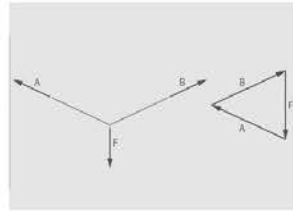

2. Graphische Statik
2. Graphic statics



3. Seile
3. Cables



4. Bogen
4. Arches



5. Bogen-Seil
5. Arch-cables

Tragwerksentwurf I *Structural Design I*

Tragwerksentwurf II *Structural Design II*

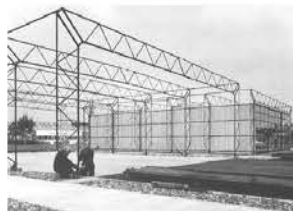

6. Fachwerke
6. Trusses



7. Balken
7. Beams



8. Rahmen
8. Frames



9. Platten
9. Plates



10. Stützen
10. Columns



11. Nachhaltigkeit
11. Sustainability

Bögen

Arches

>> Seil und Bogen – Inversionsprinzip
Cables and arches – inversion principle

Fallbeispiel: Gotische Kathedrale
Case study: Gothic cathedral

Aussteifungskonzepte
Concepts for stiffening

Stützlinien
Thrust lines

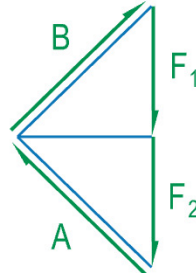
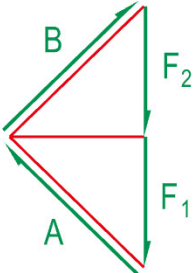
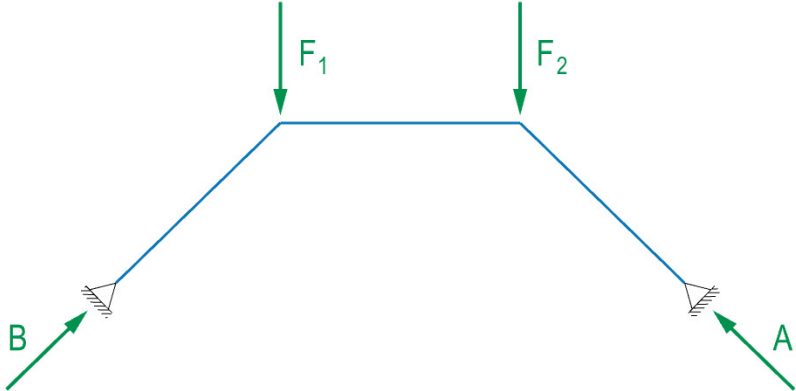
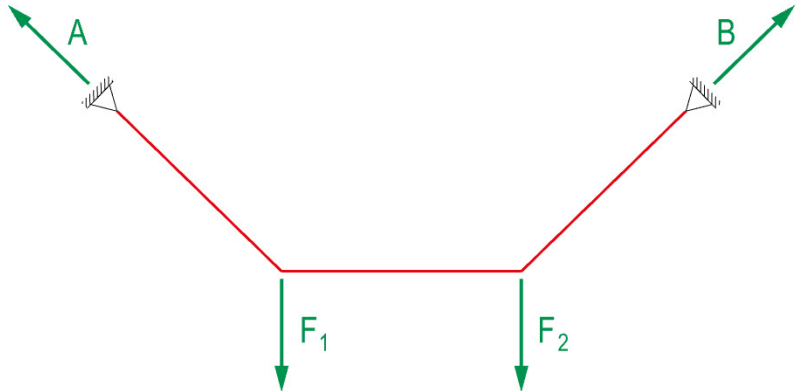



Wilhelm Riphahn, Fritz Leonhardt: Mülheimer bridge, Cologne, 1951



Robert Maillart: Valtschielbachbridge, Donath, 1925

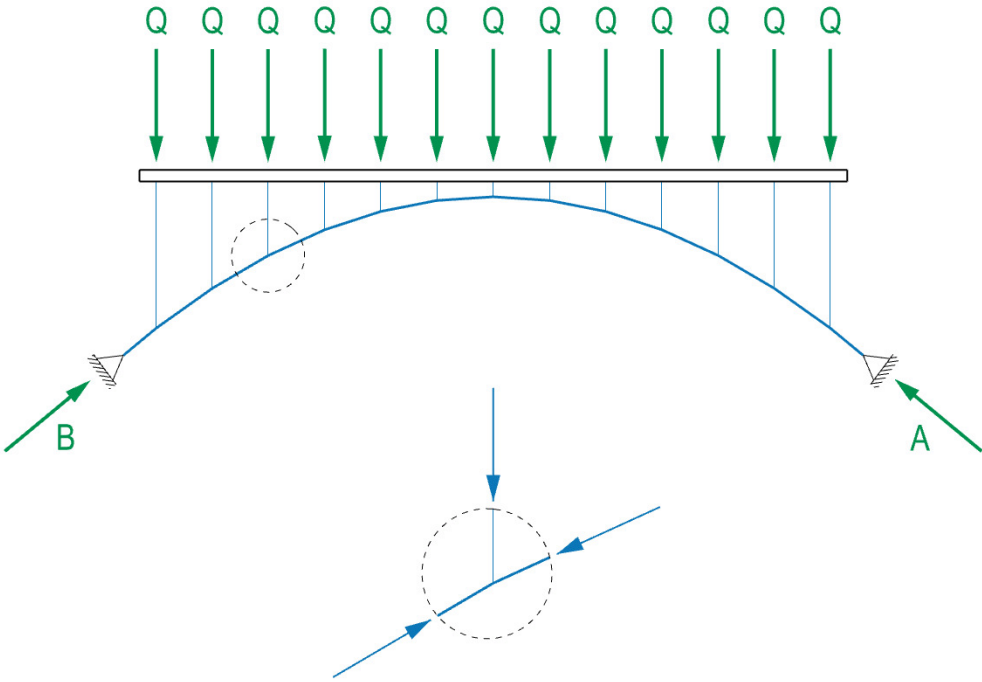
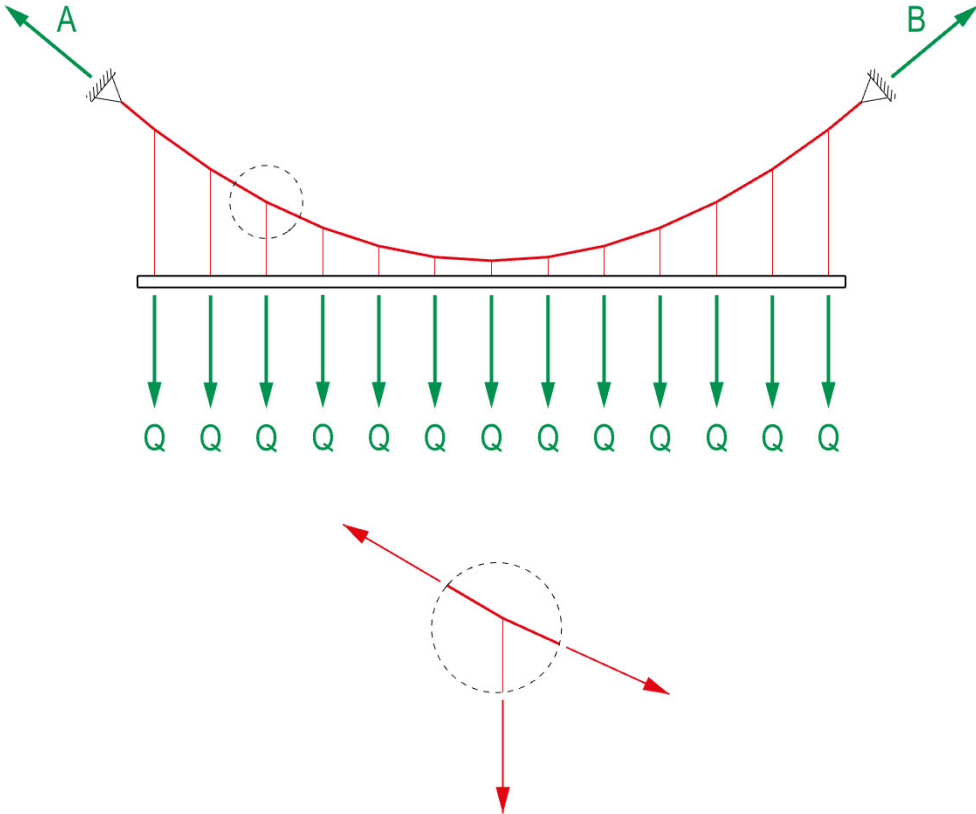

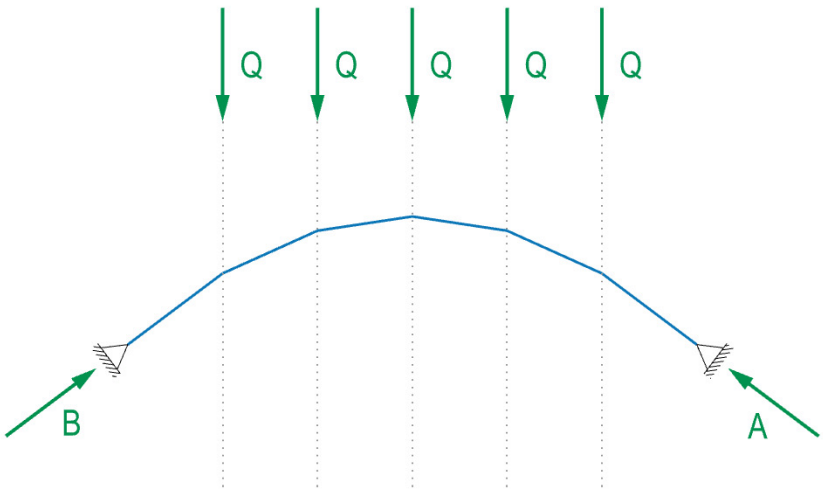
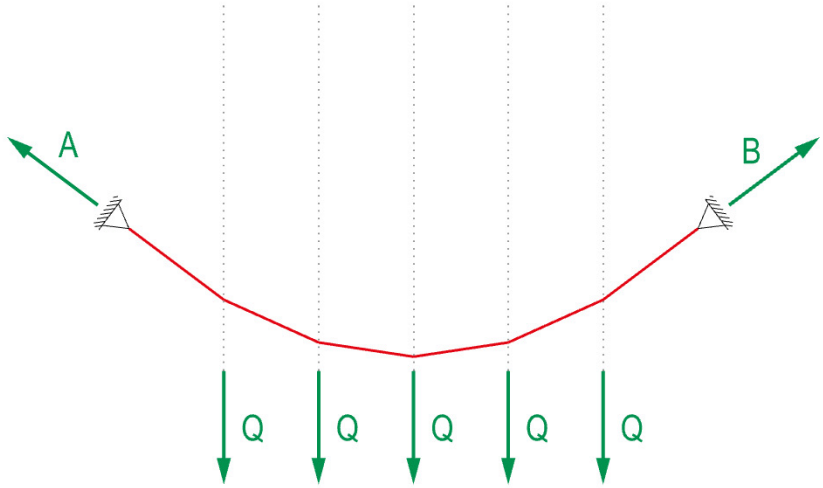
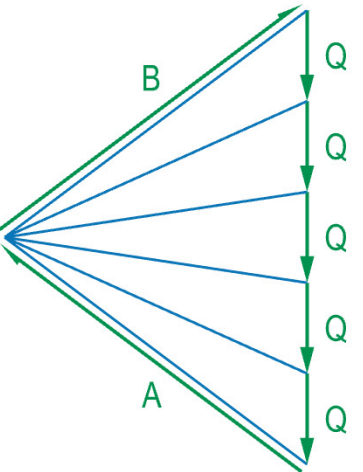
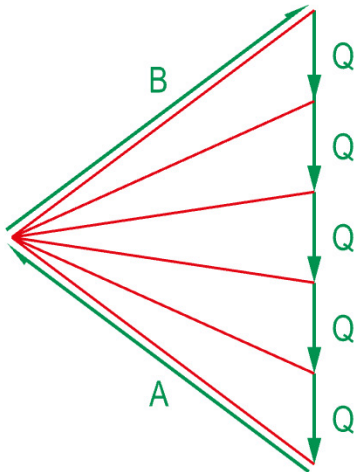

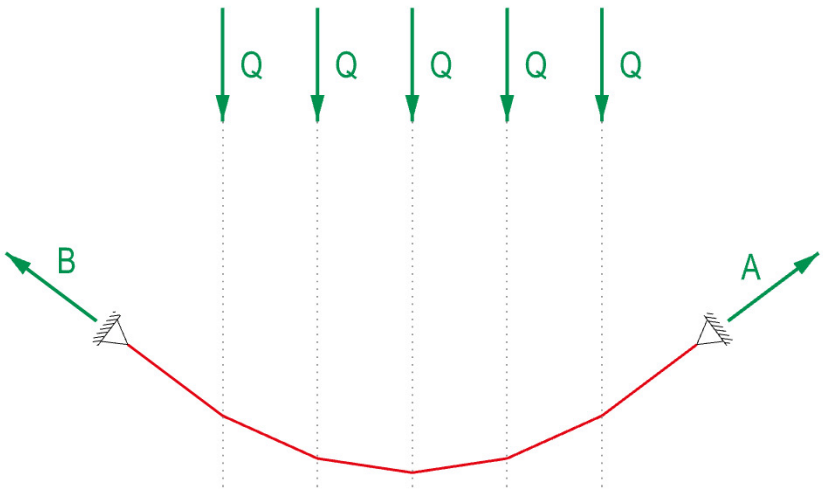
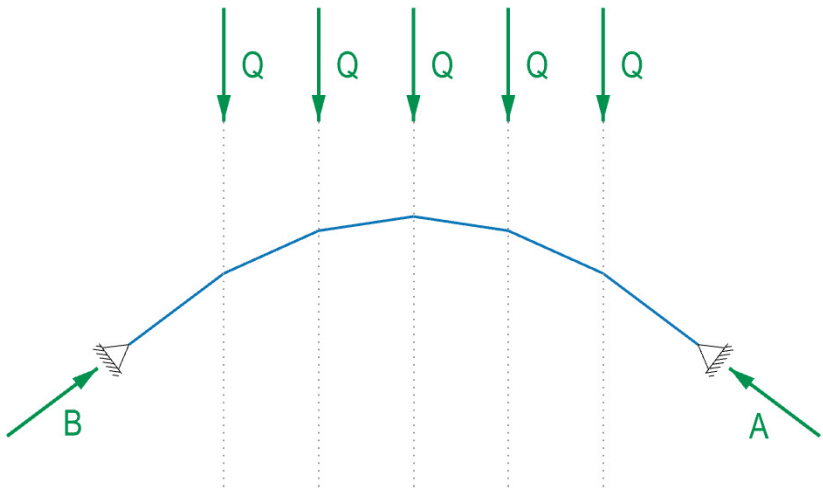
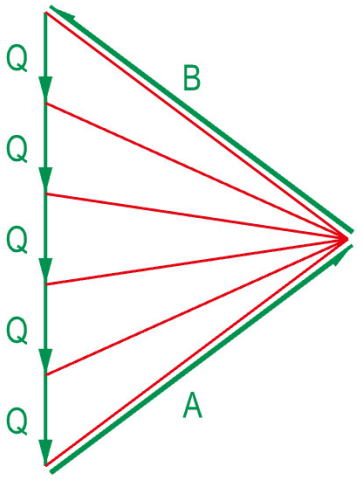
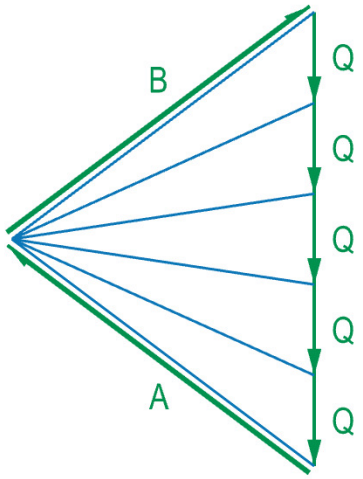

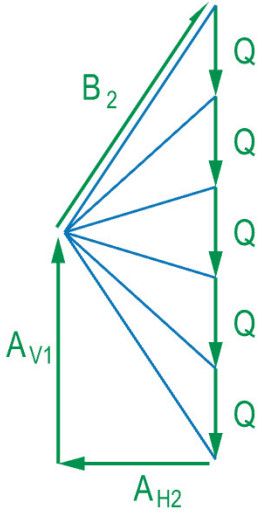
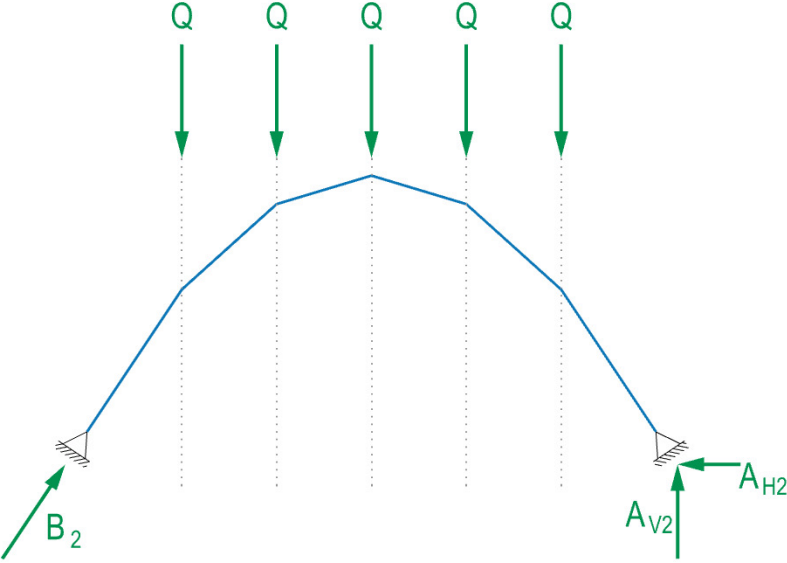
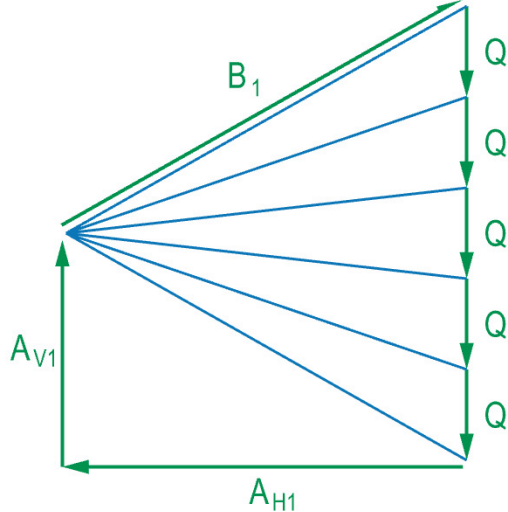
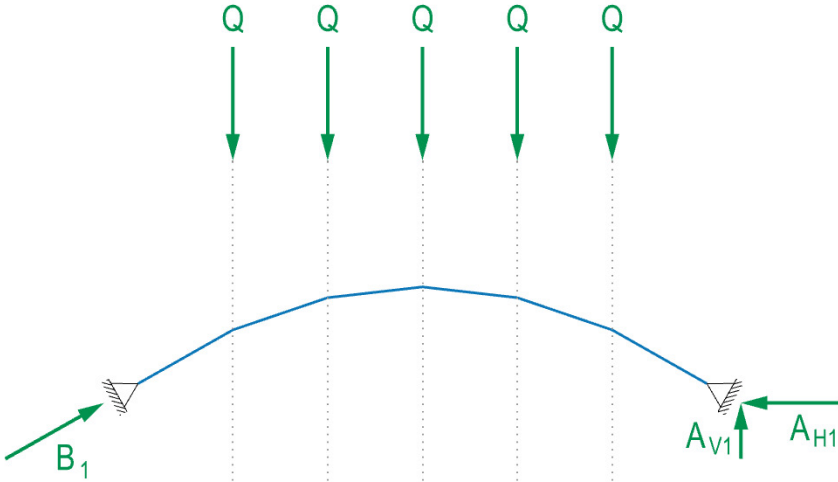

abcccddeeeefggiiiiillmmmmnnnnnooprssstttttuuuuuuux

abcccddeeeefggiiiiiiiillmmmmnnnnnooprssstttttuuuuuuux

ut pendet continuum flexile, sic stabit contiguum rigidum inversum

abcccddeeeefggiiiiiiiillmmmmnnnnnooprssstttttuuuuuuux

ut pendet continuum flexile, sic stabit contiguum rigidum inversum

„As hangs the flexible line, so but inverted will stand the rigid arch.“

abcccddeeeefggiiiiiiiillmmmmnnnnnooprssstttttuuuuuuux

ut pendet continuum flexile, sic stabit contiguum rigidum inversum

„As hangs the flexible line, so but inverted will stand the rigid arch.“

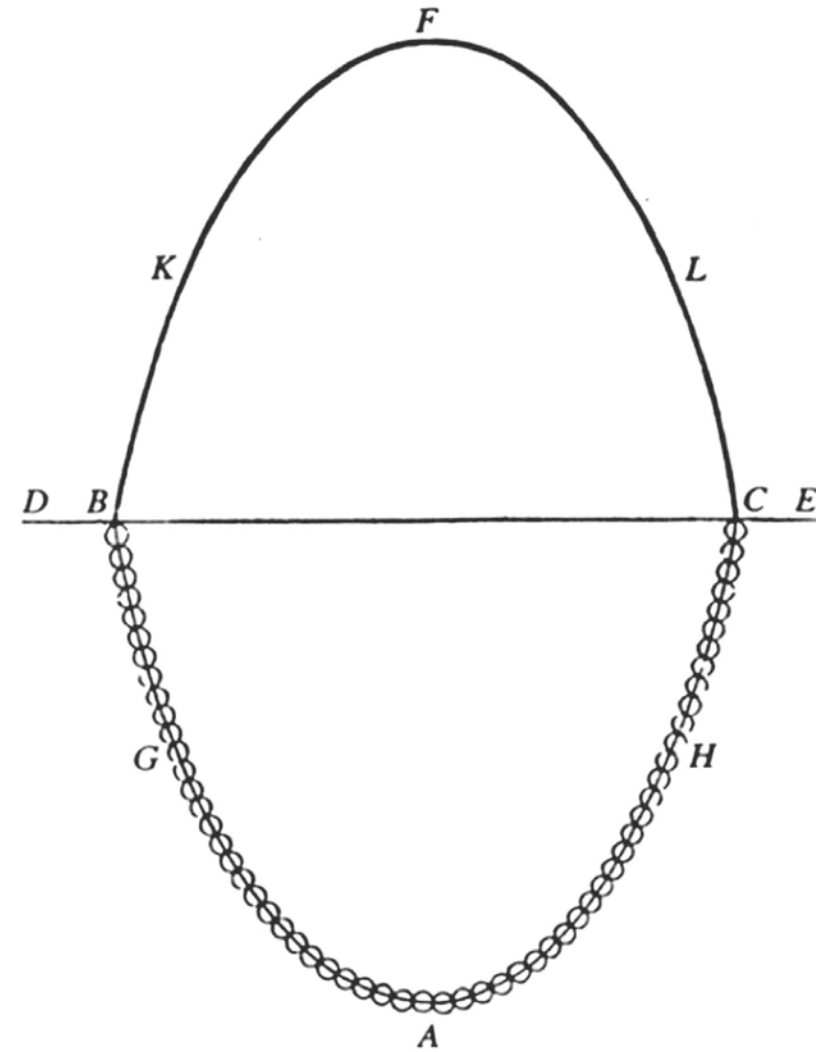



Modell of Colonia Güell church and crypt of Colonia Güell, Antonio Gaudí, 1898-1914

Bögen

Arches

Seil und Bogen – Inversionsprinzip

Cables and arches – inversion principle



Fallbeispiel: Gotische Kathedrale

Case study: Gothic cathedral

Aussteifungskonzepte

Concepts for stiffening

Stützlinien

Thrust lines

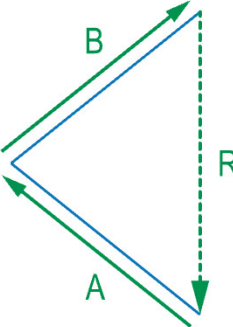
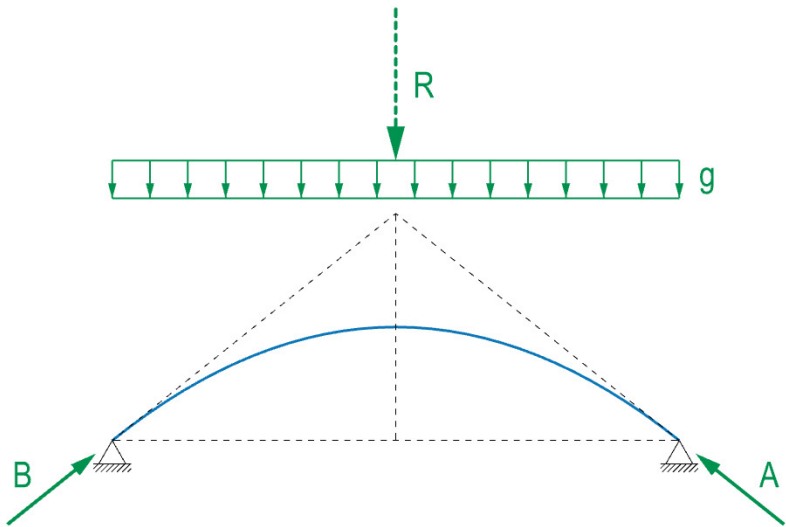

Case study: Gothic cathedral

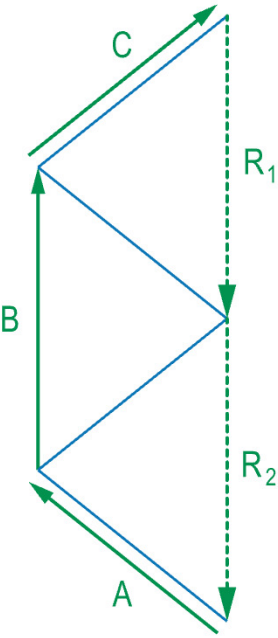
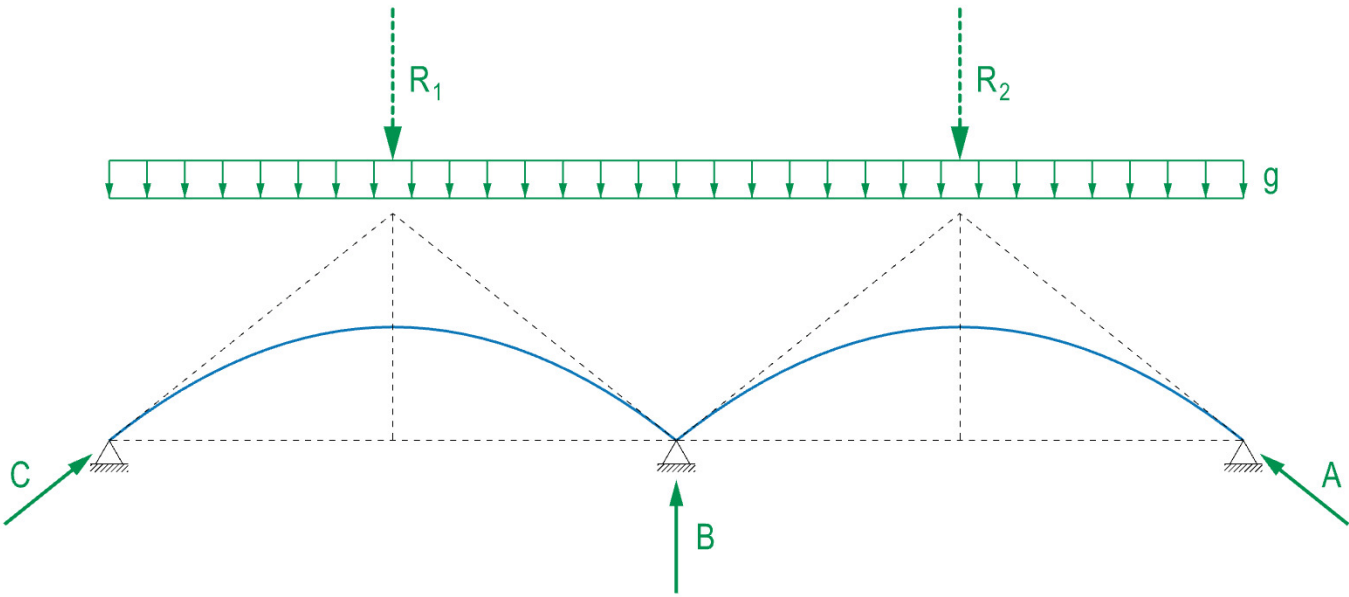

Case study: Gothic cathedral

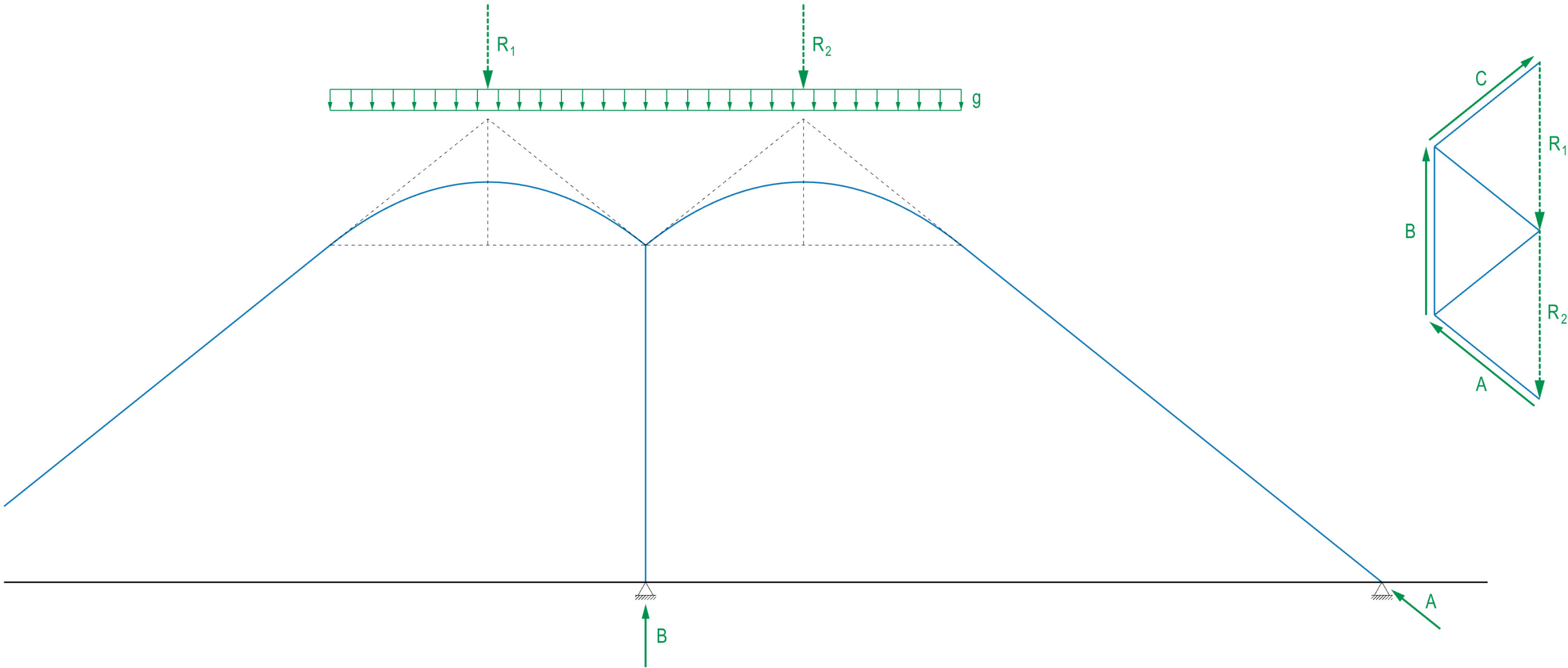

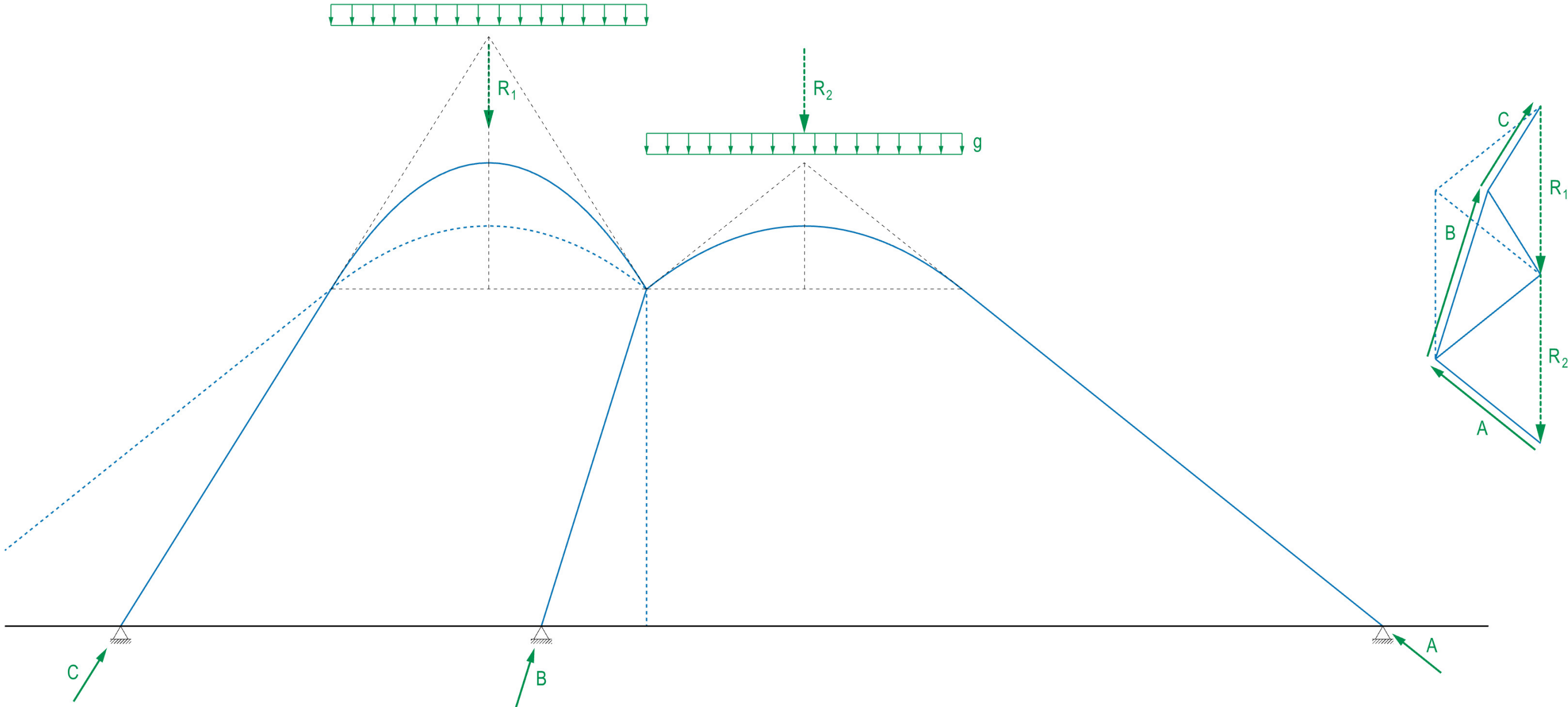

Case study: Gothic cathedral

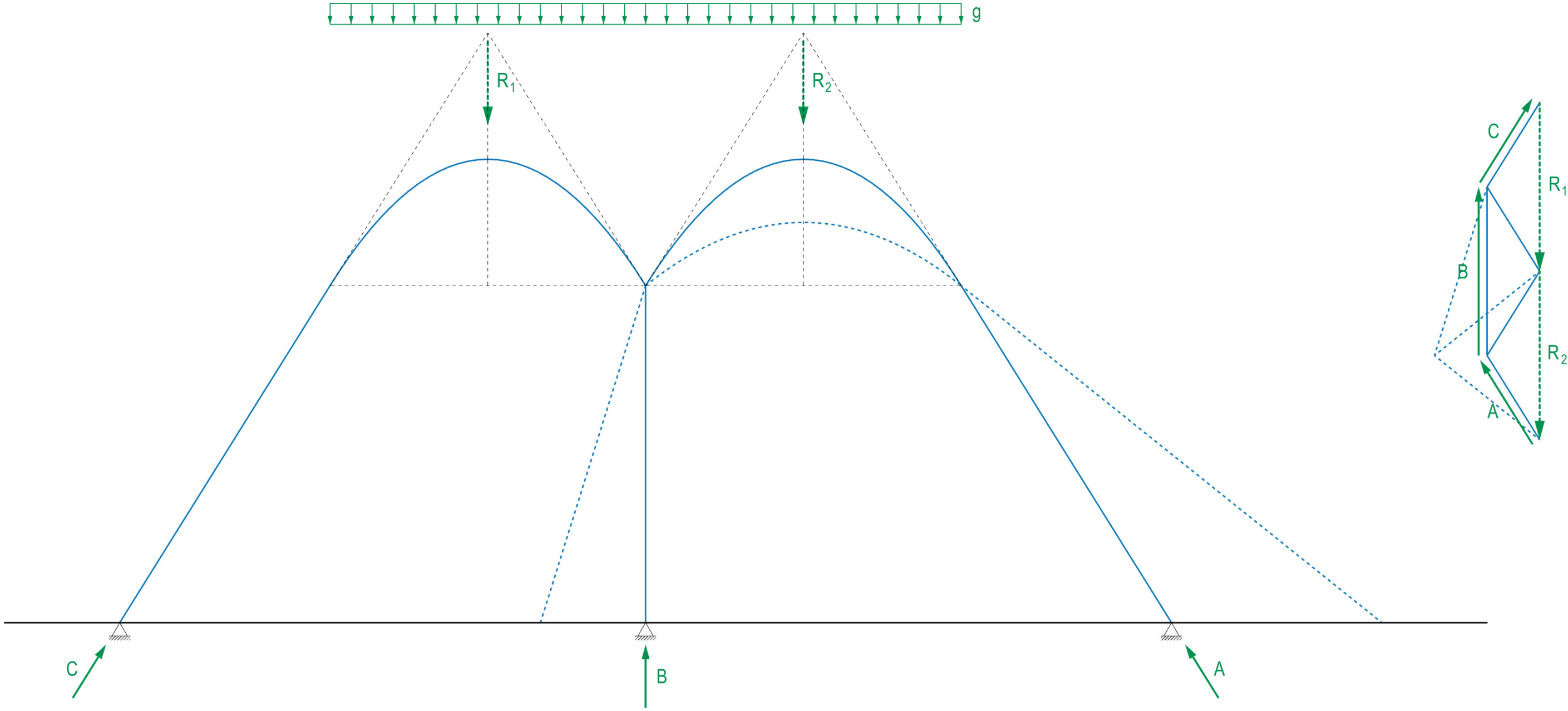

Case study: Gothic cathedral

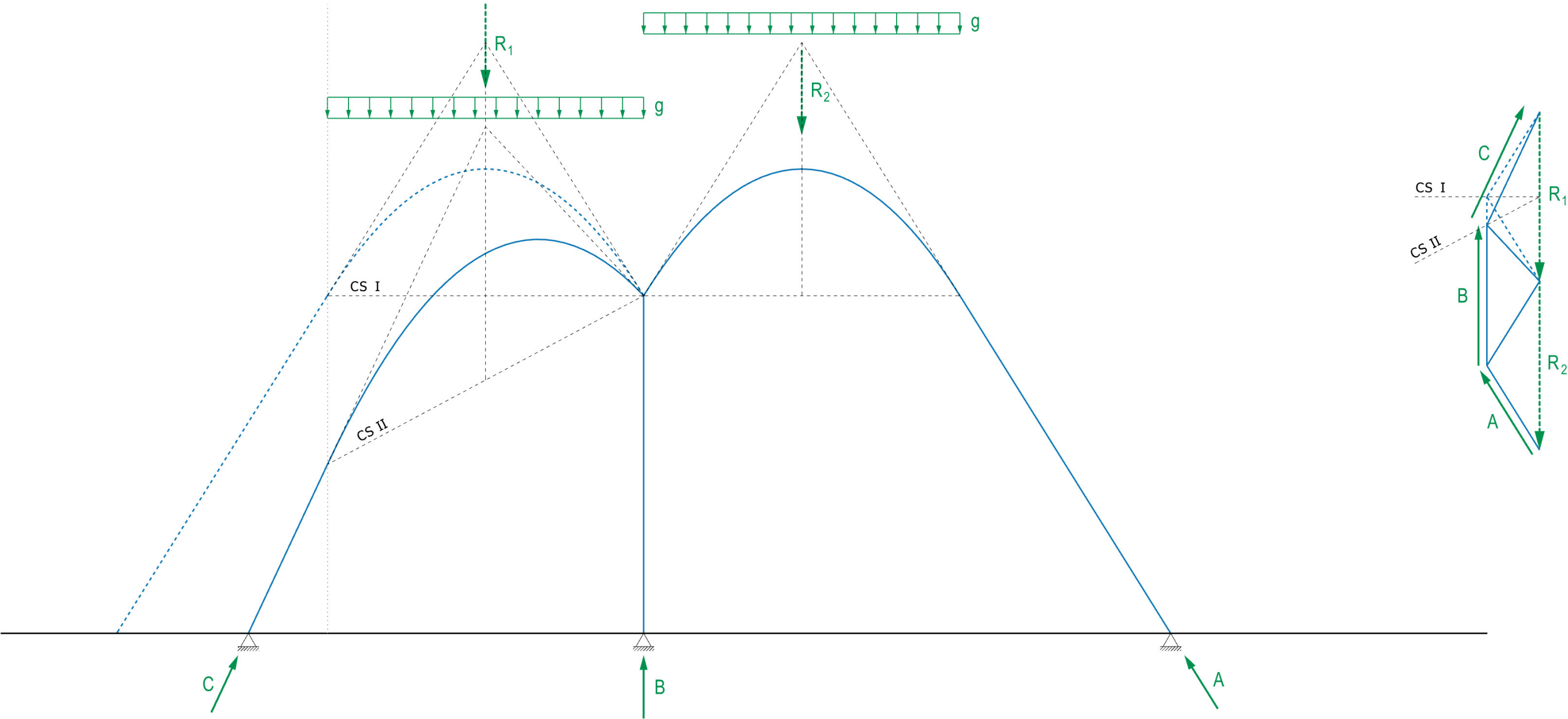

Case study: Gothic cathedral

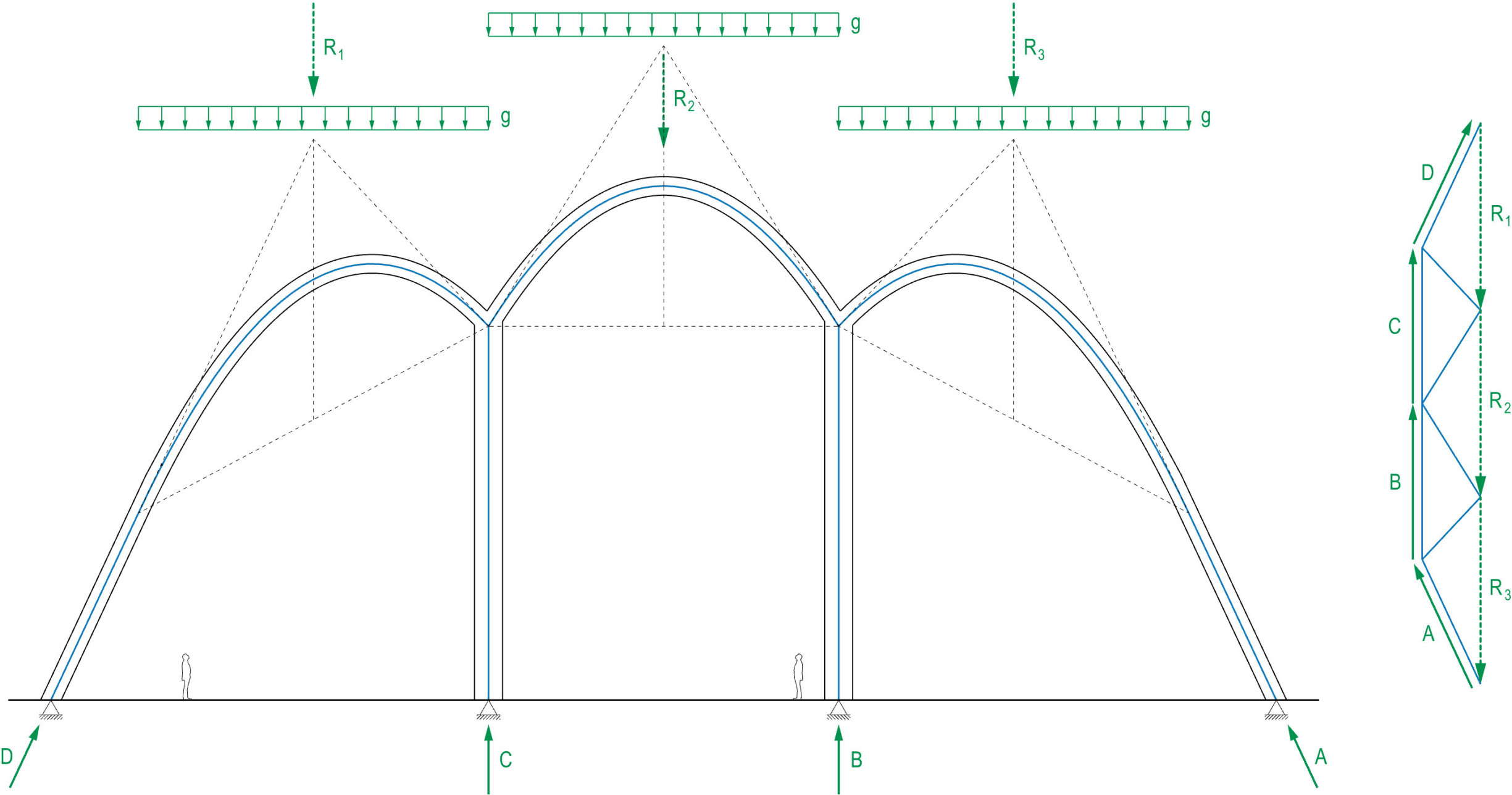

Case study: Gothic cathedral

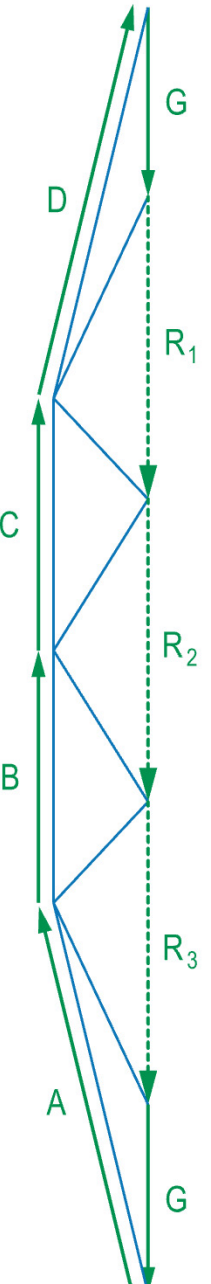
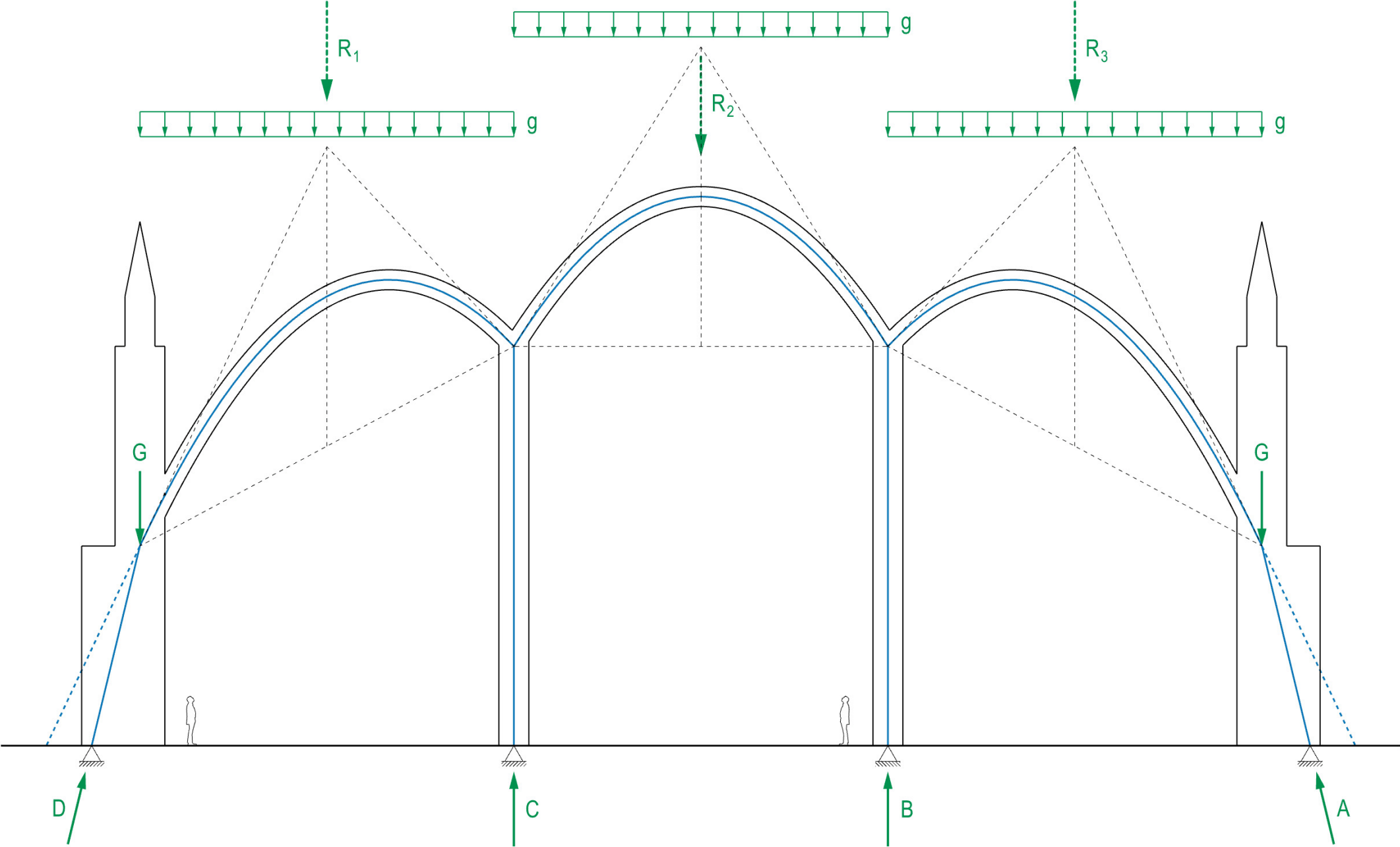

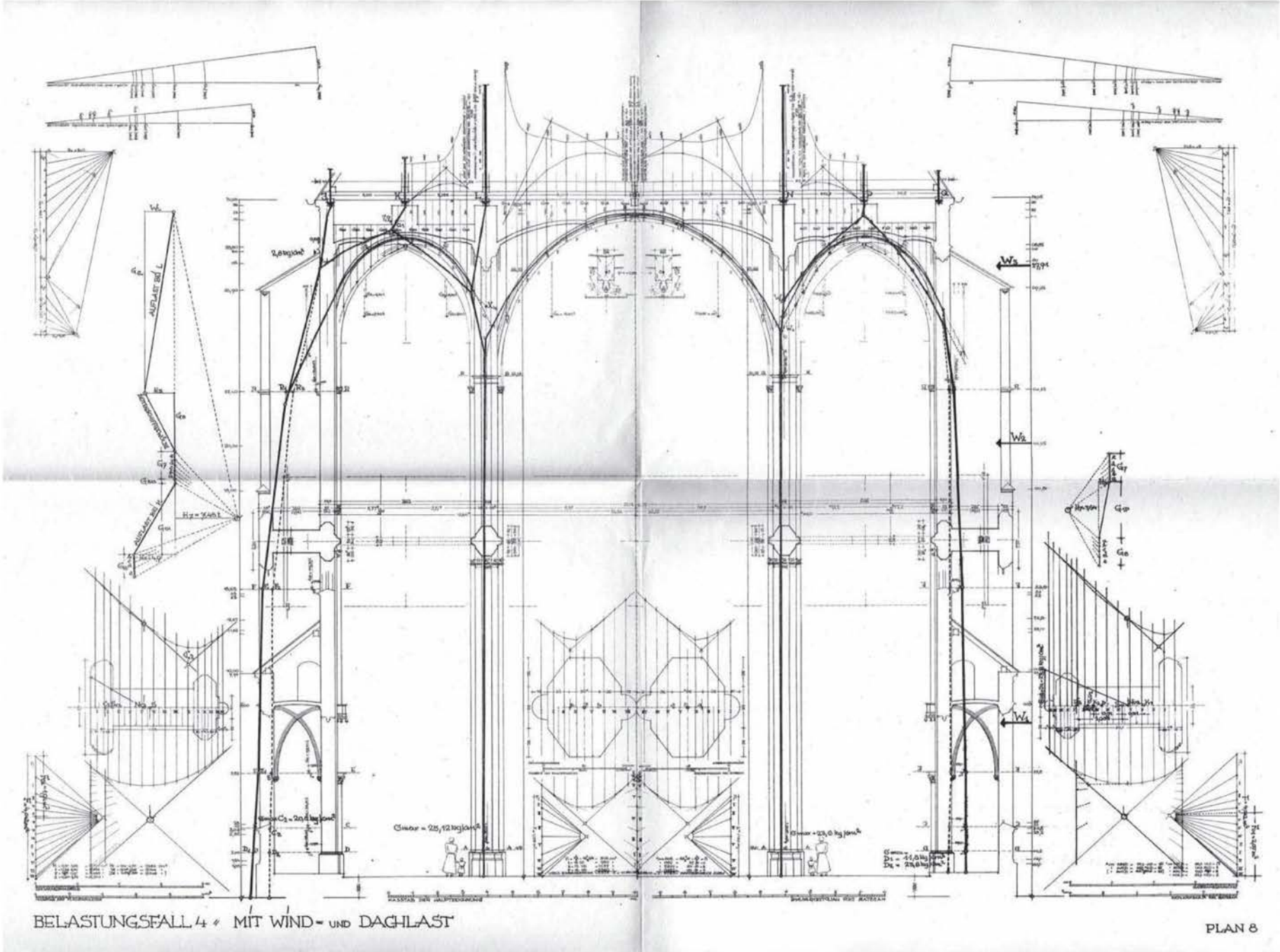



Beauvais Cathedral, France, 1247



Beauvais Cathedral, France, 1247

Bögen

Arches

Seil und Bogen – Inversionsprinzip

Cables and arches – inversion principle

Fallbeispiel: Gotische Kathedrale

Case study: Gothic cathedral



Aussteifungskonzepte

Concepts for stiffening

Stützlinien

Thrust lines

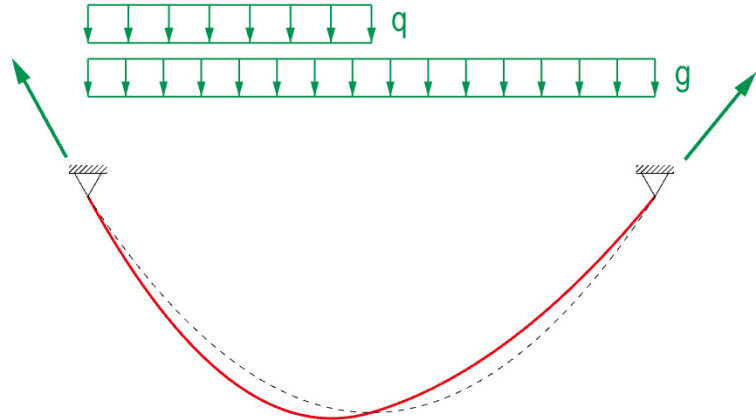

=

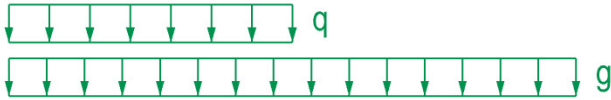
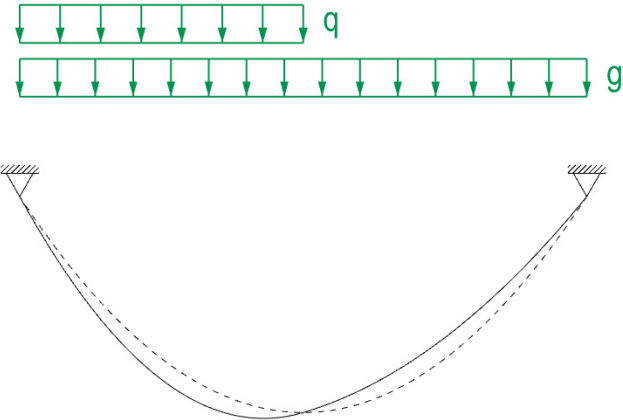

≠

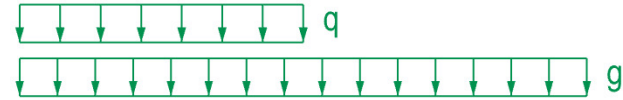
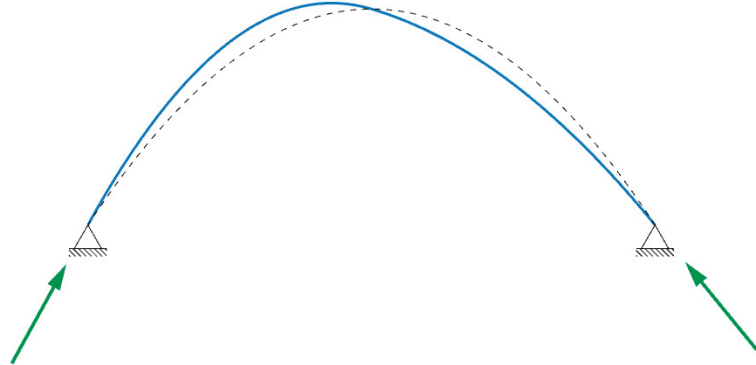

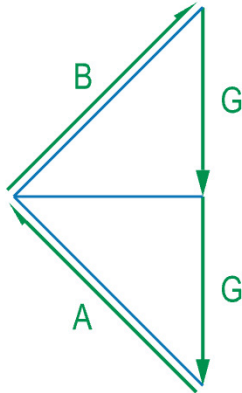
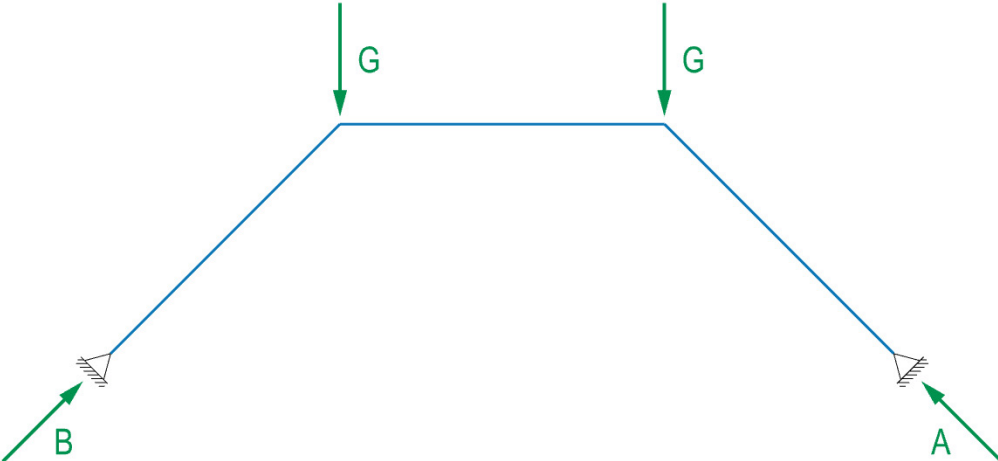

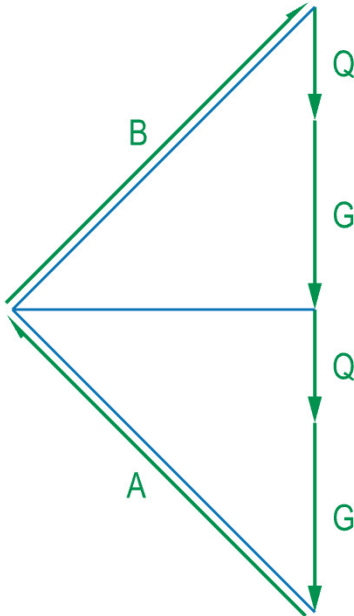
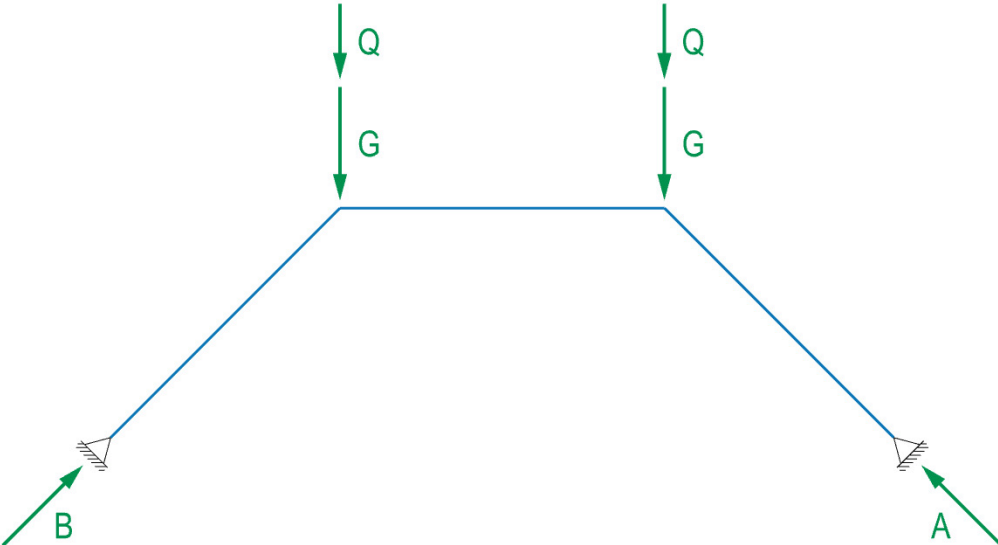

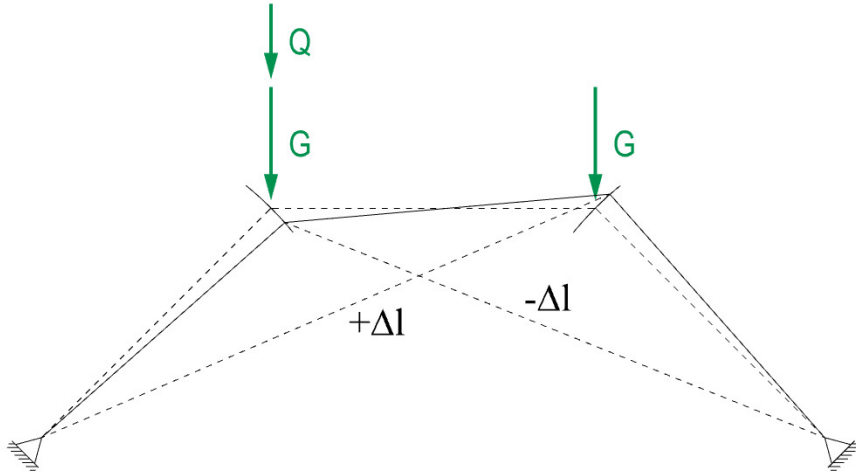

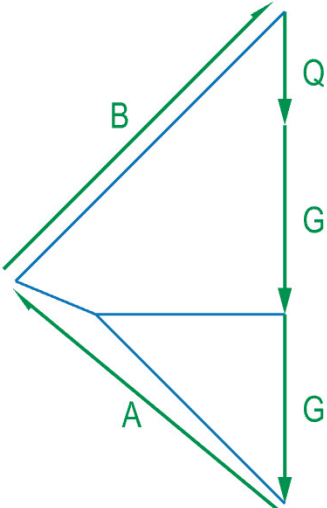
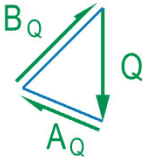
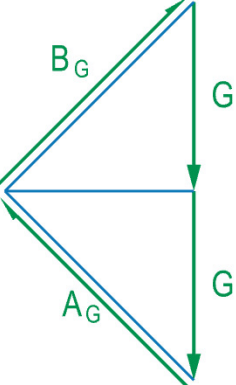
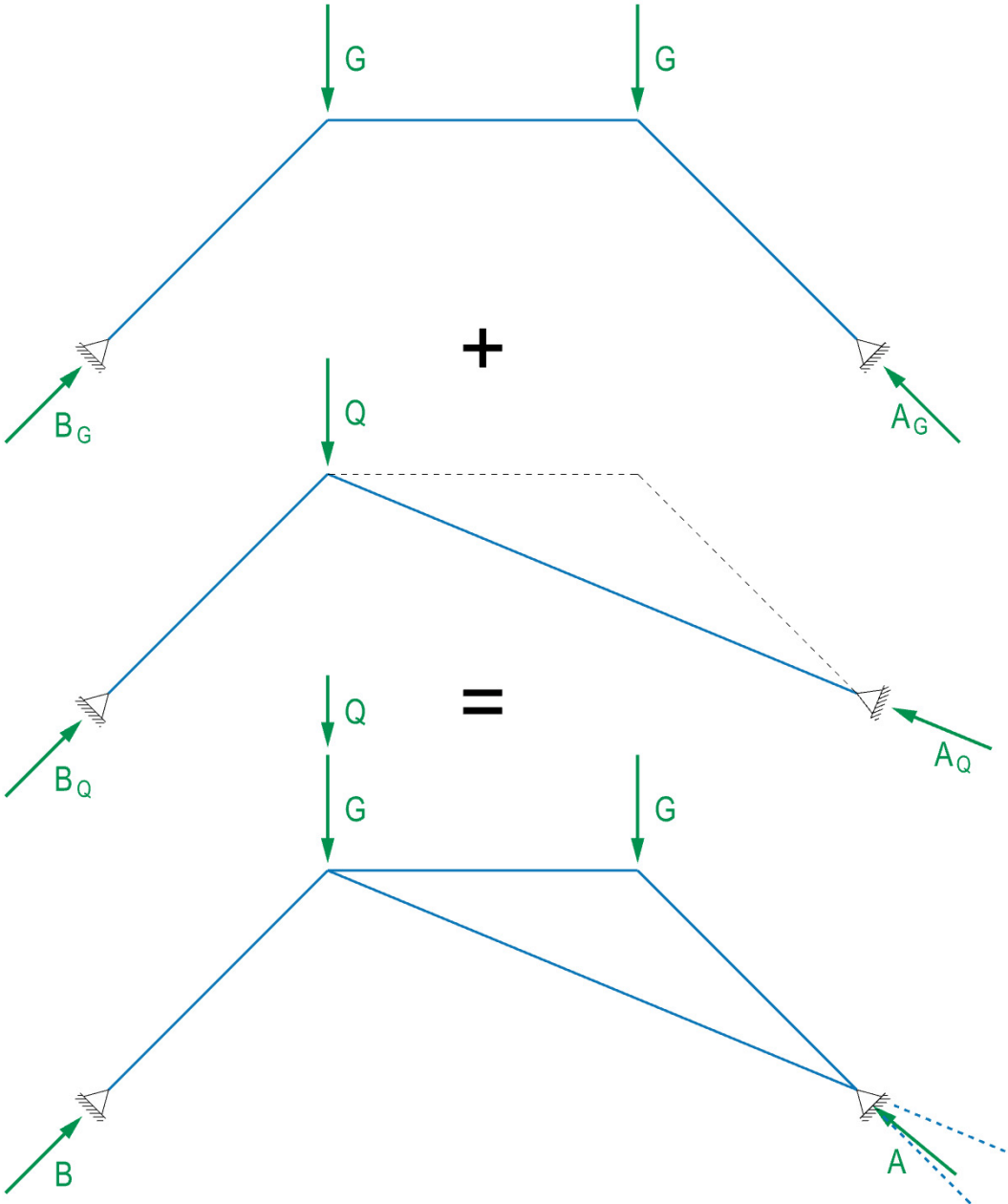

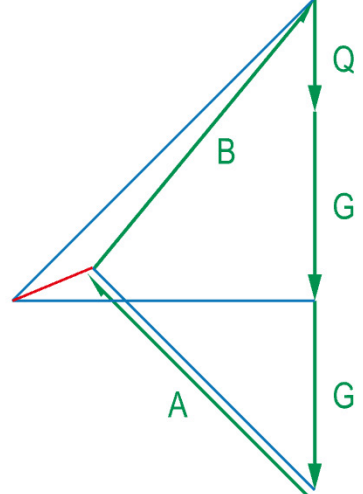
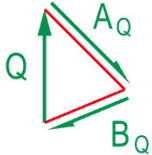
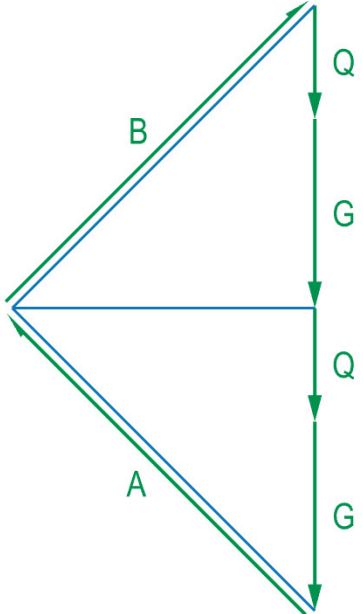
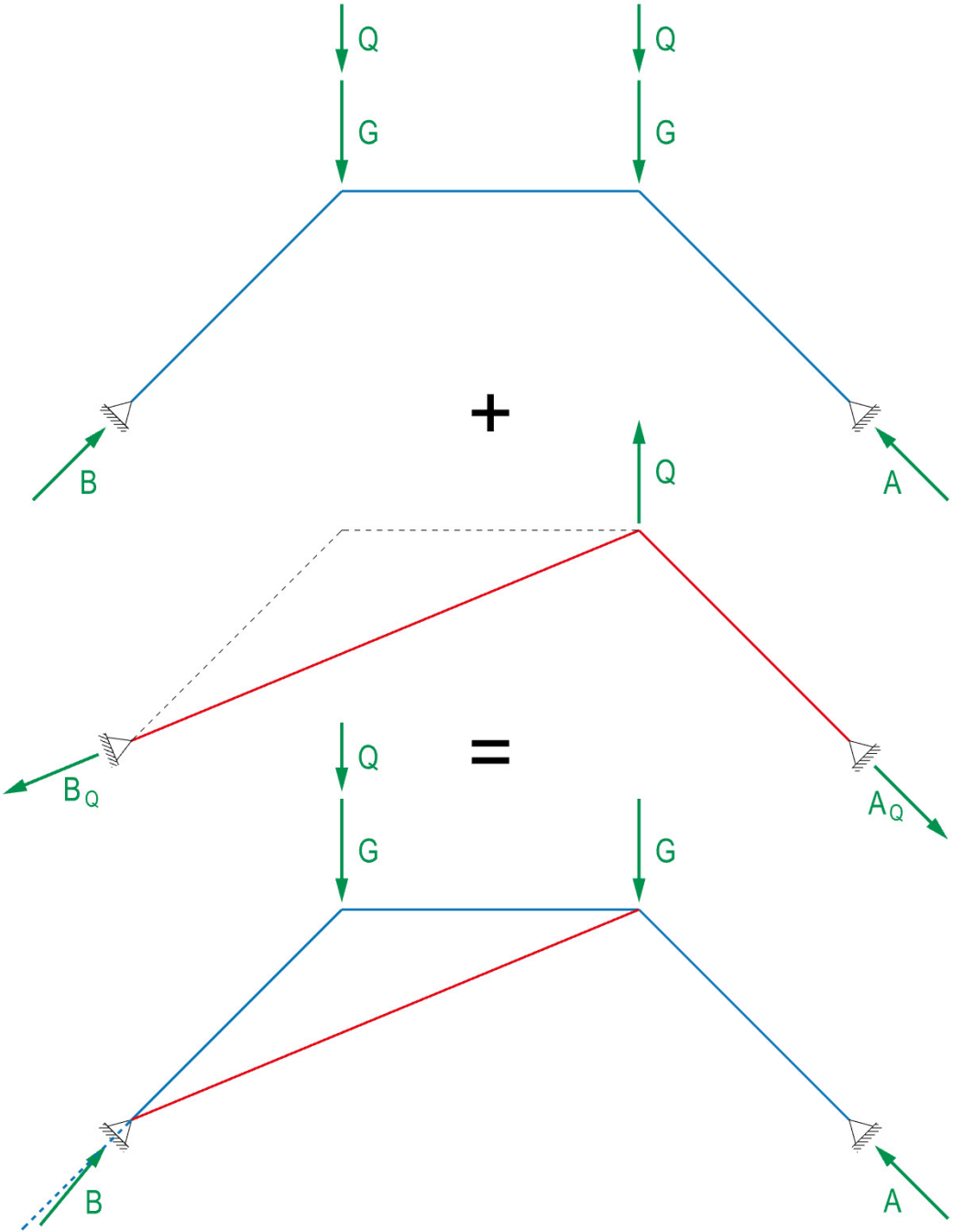

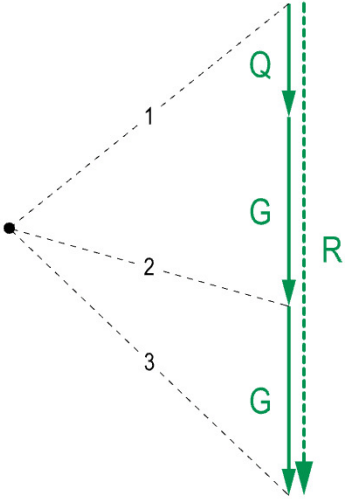
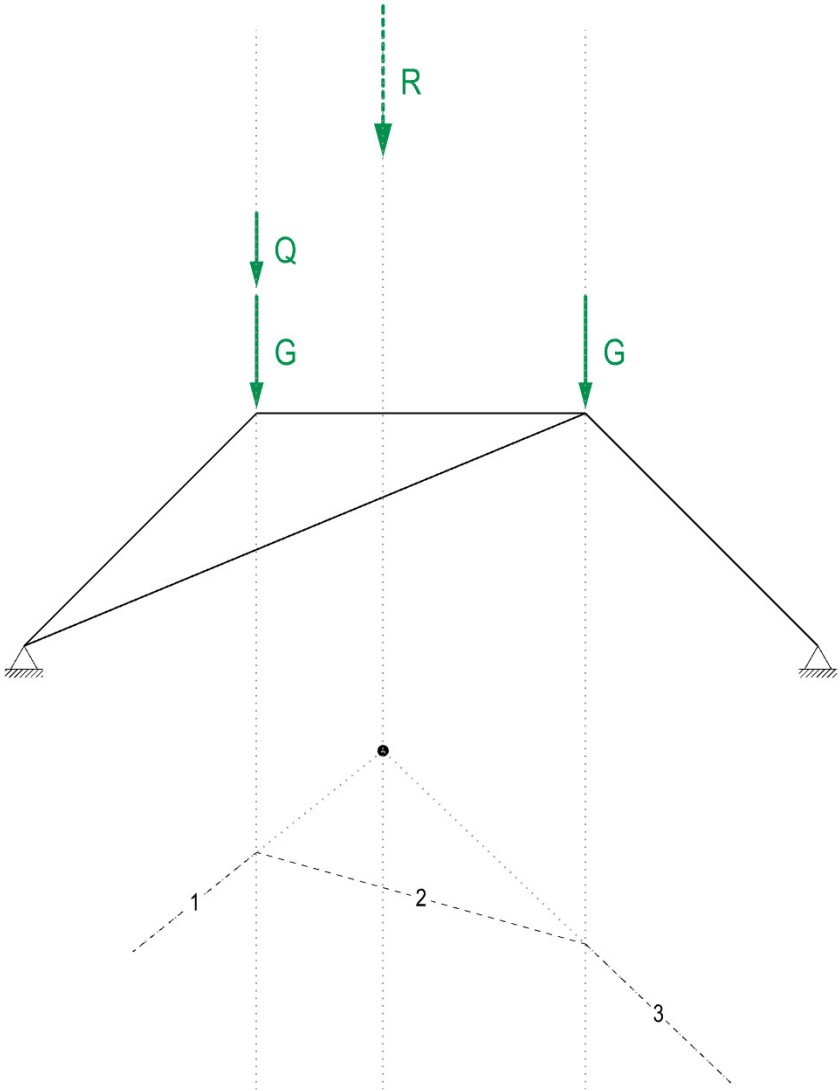

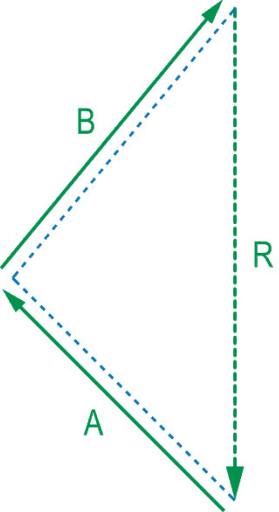
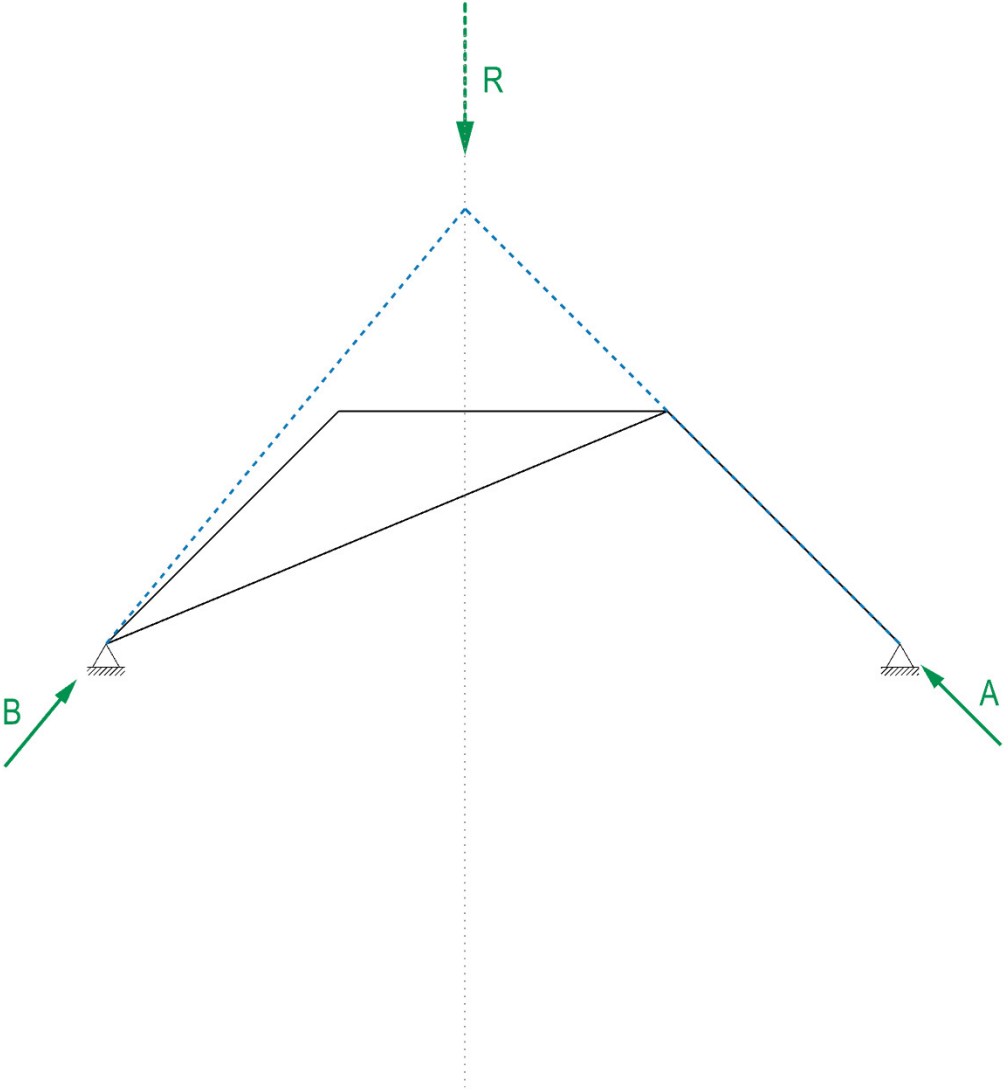

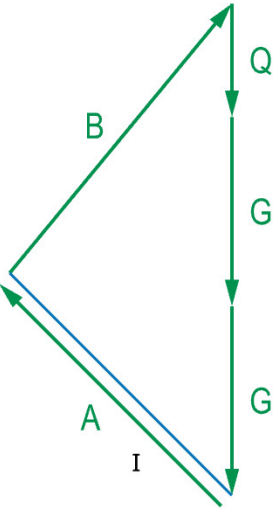
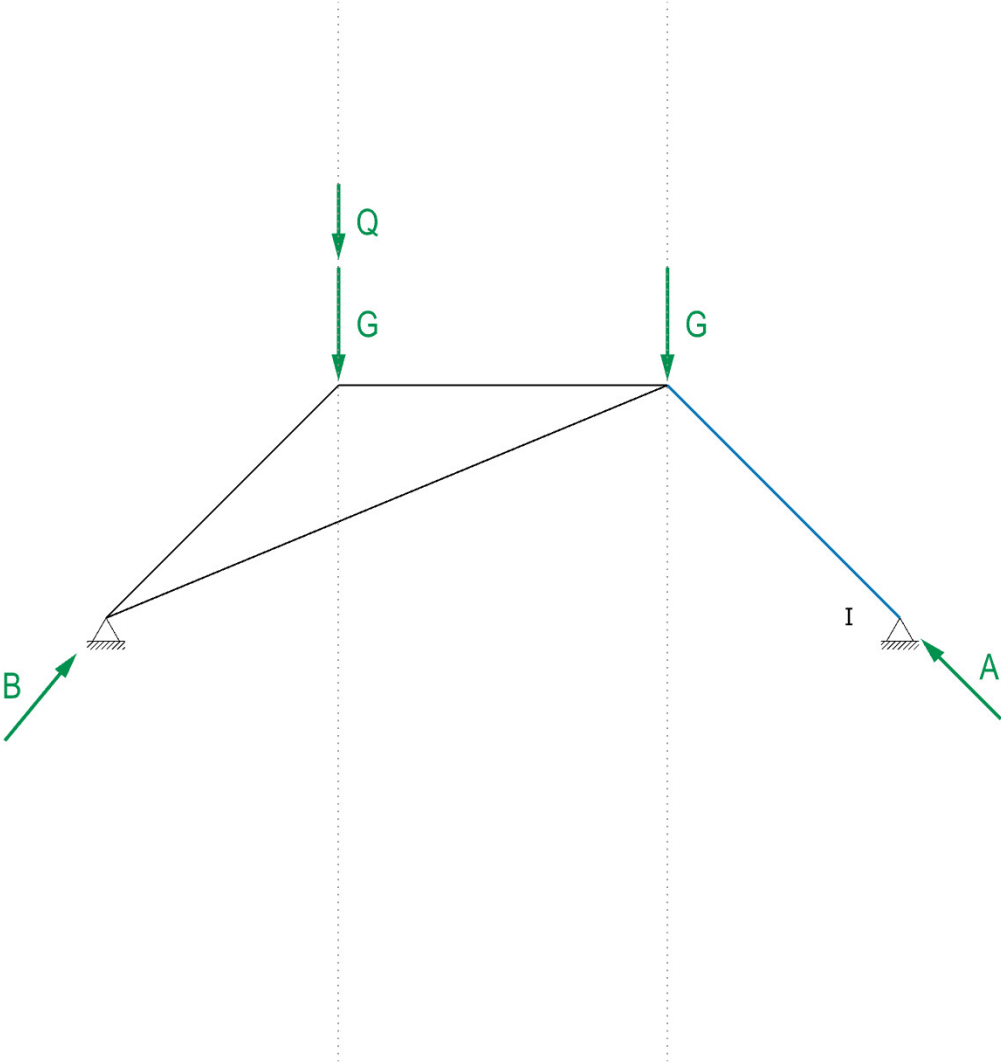

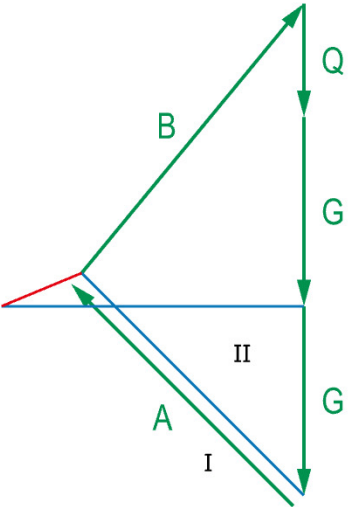
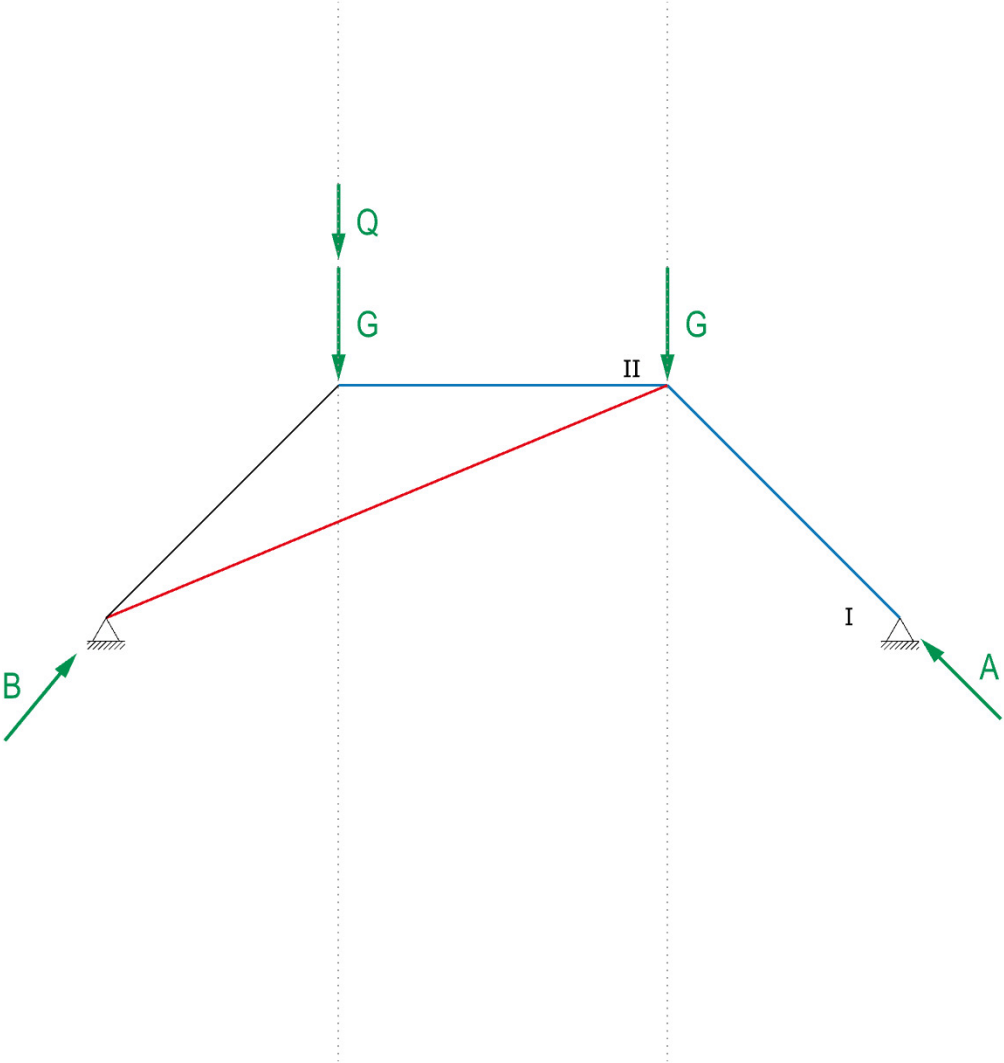

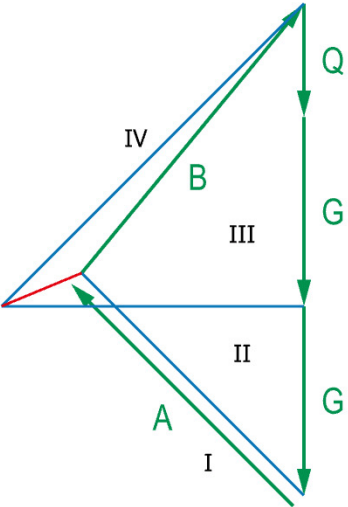
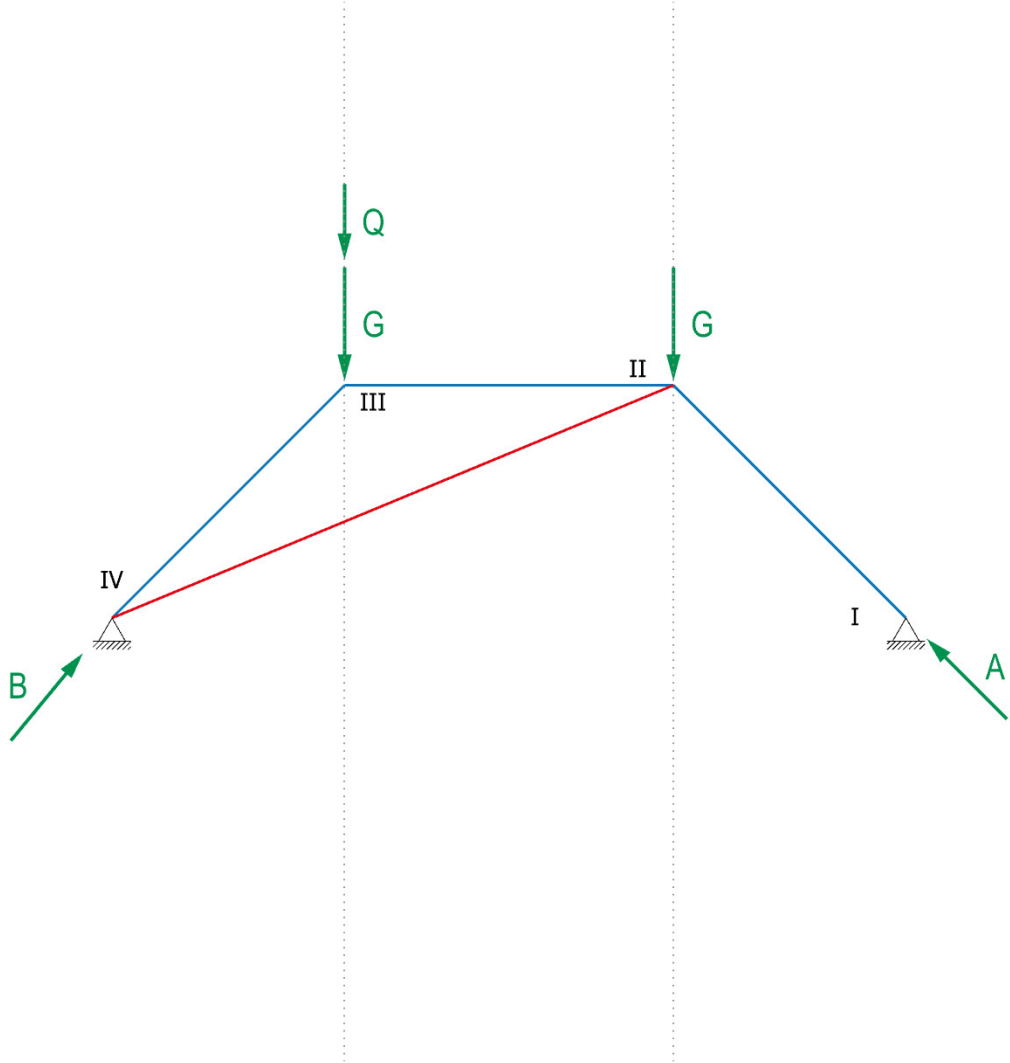

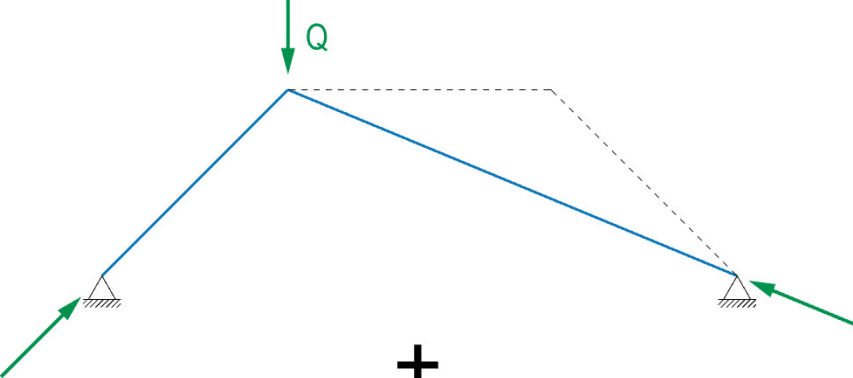

+

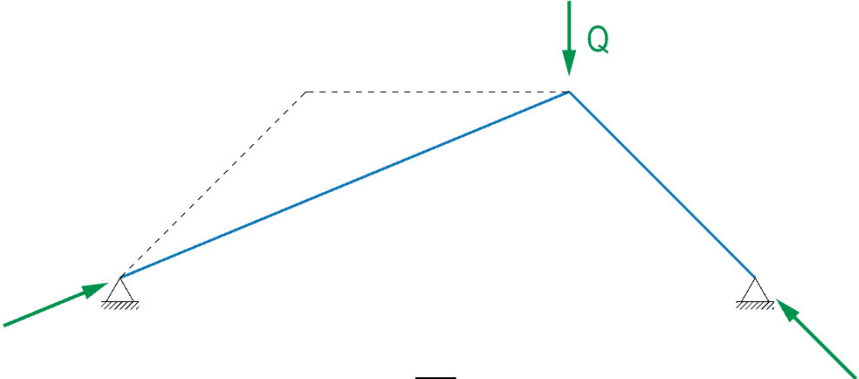

=

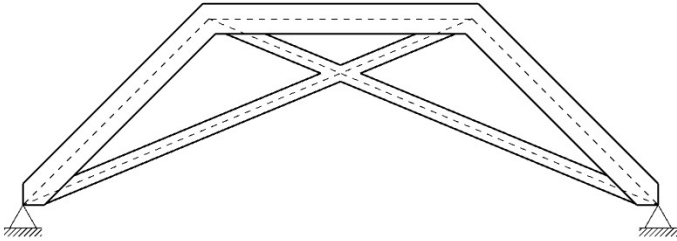

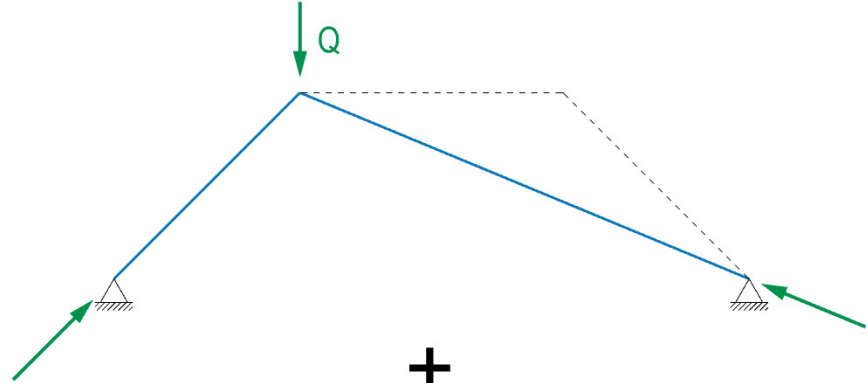

+

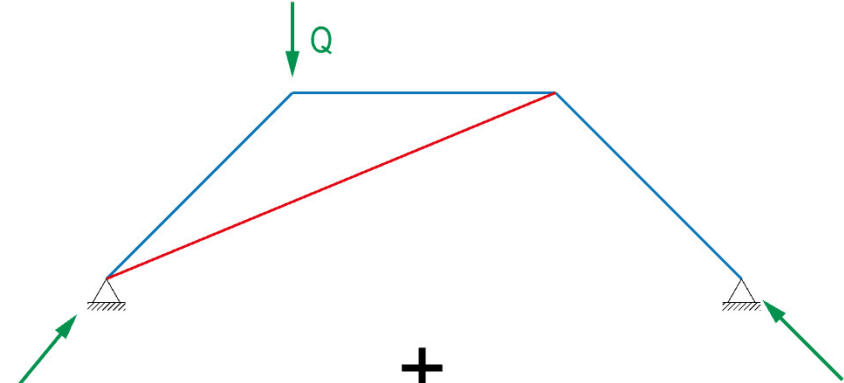

+

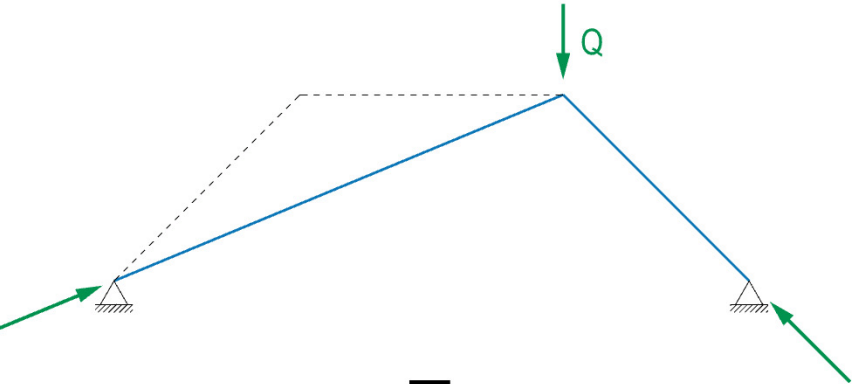

=

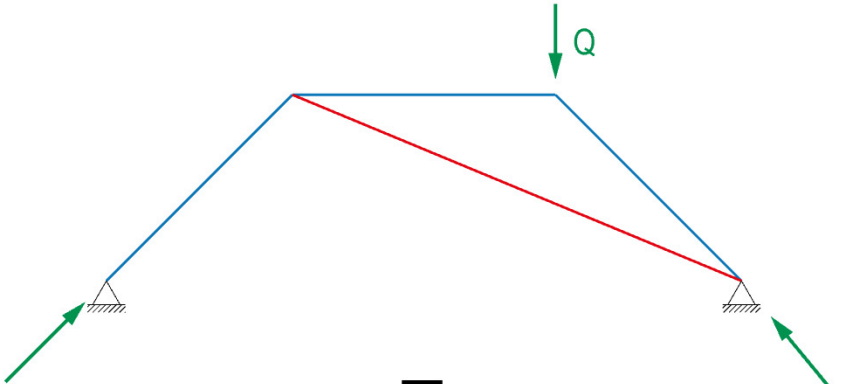

=

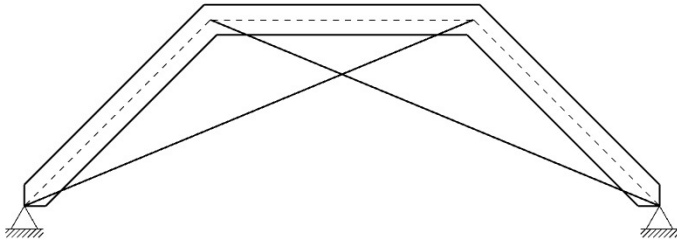
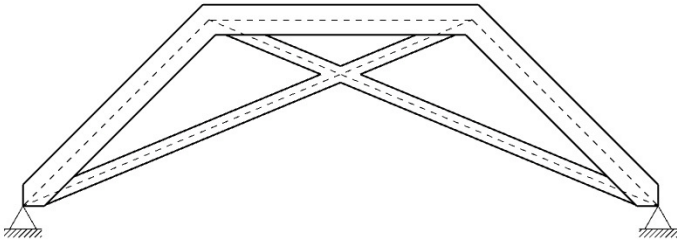

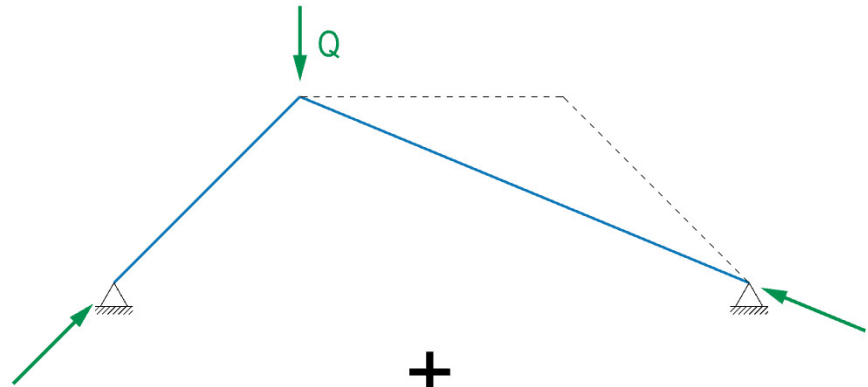

+

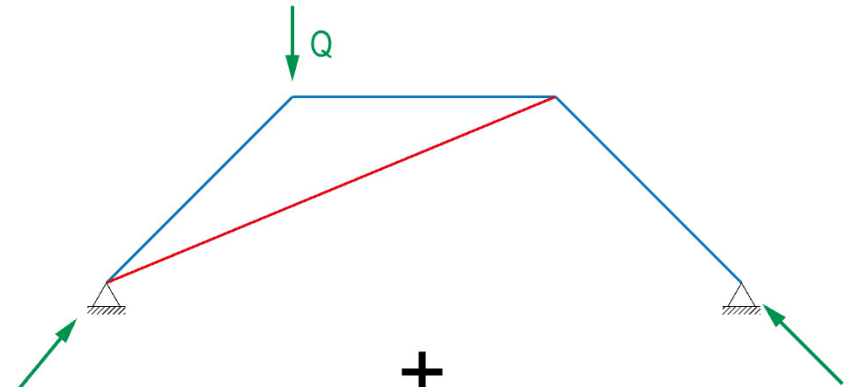

+

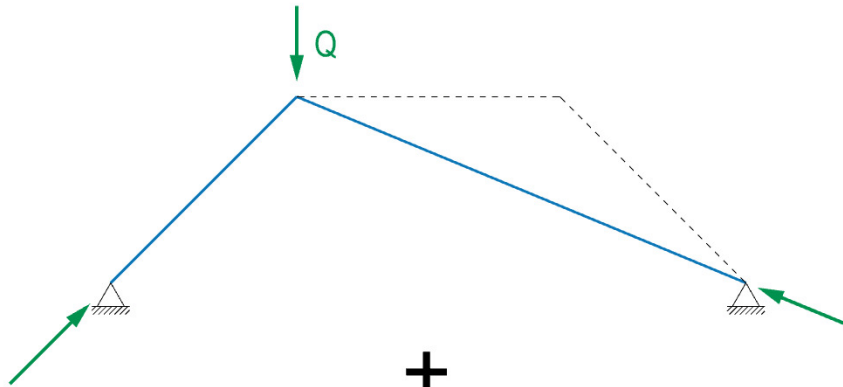

+

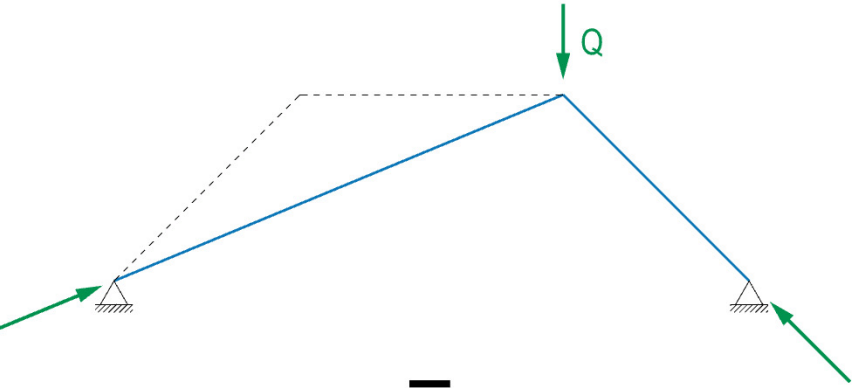

=

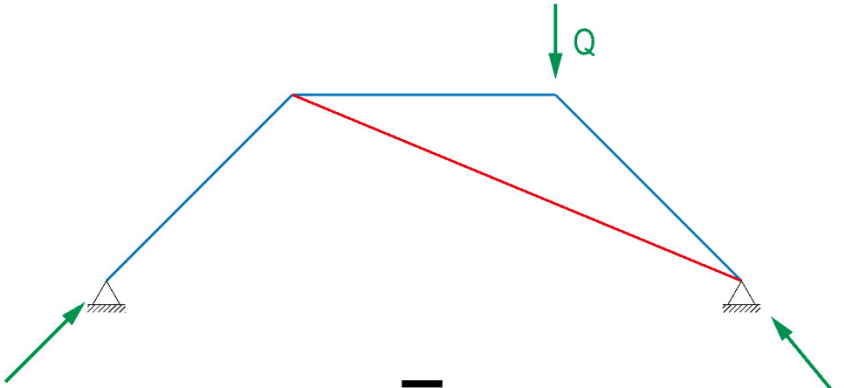

=

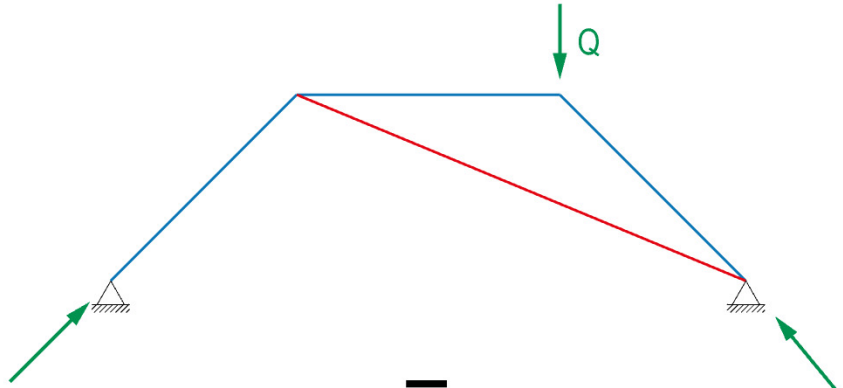

=

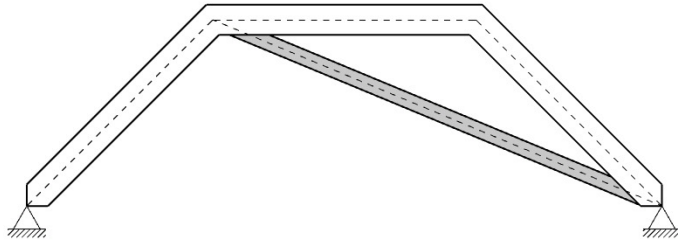
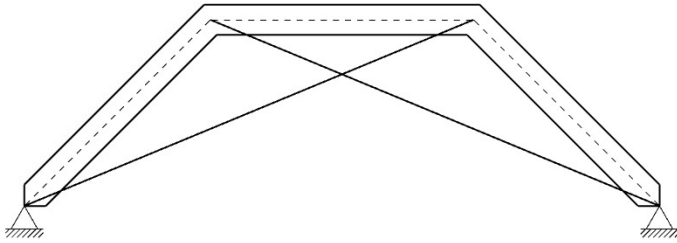
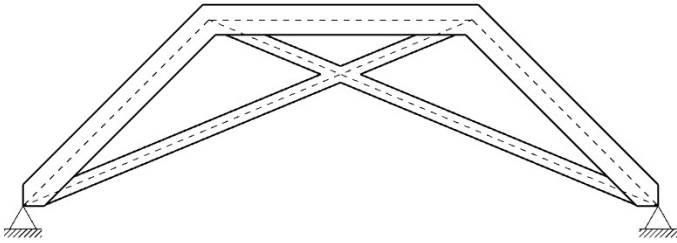

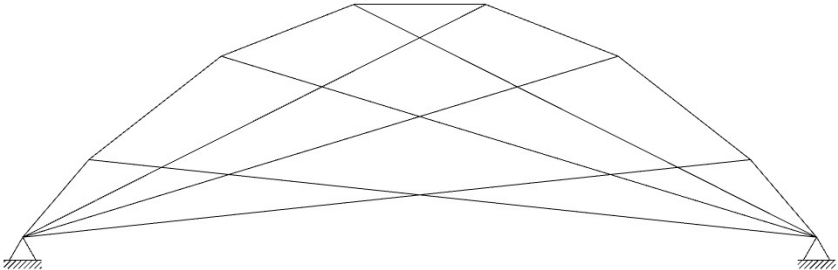
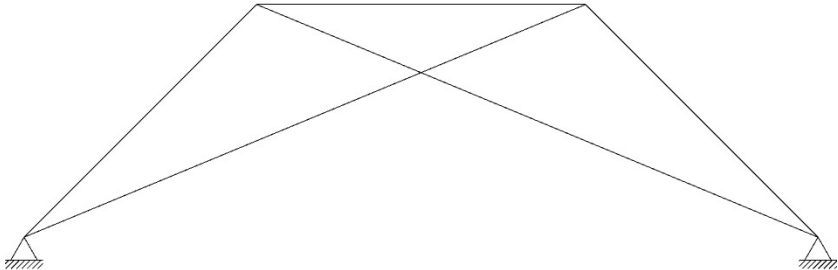

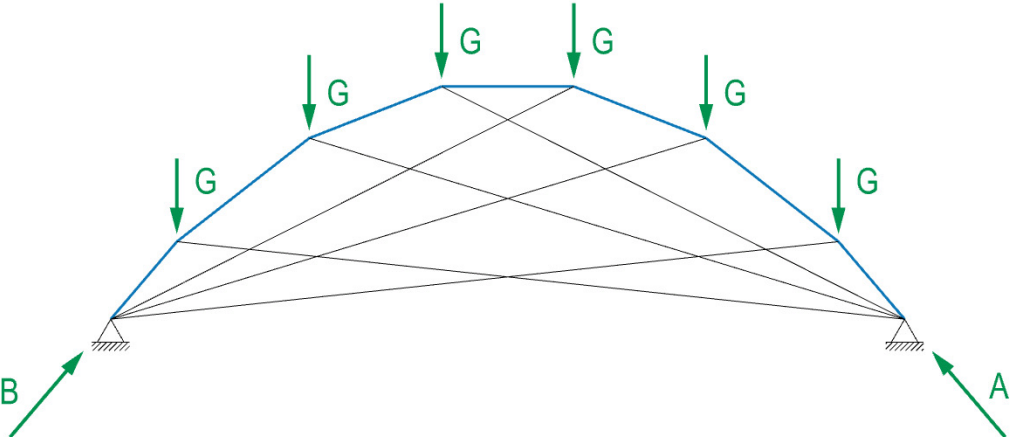
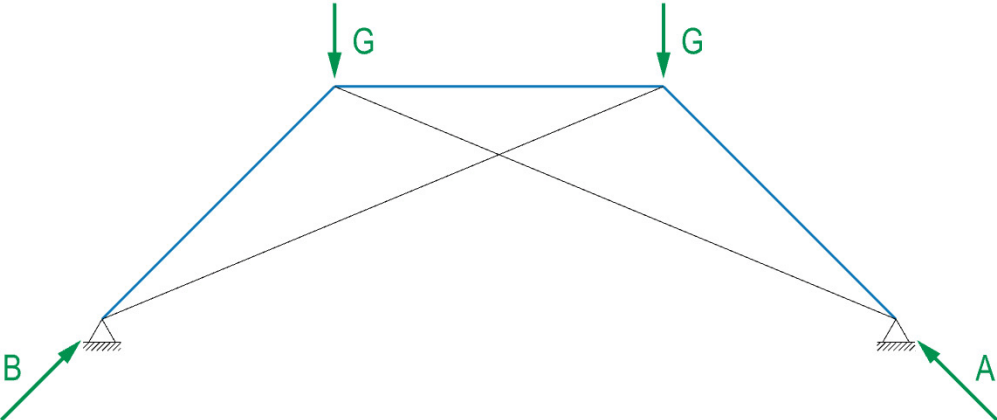

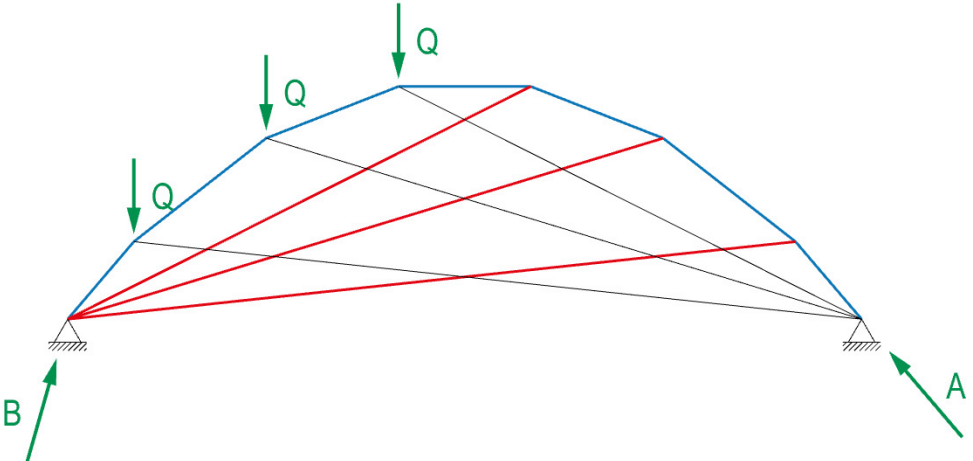
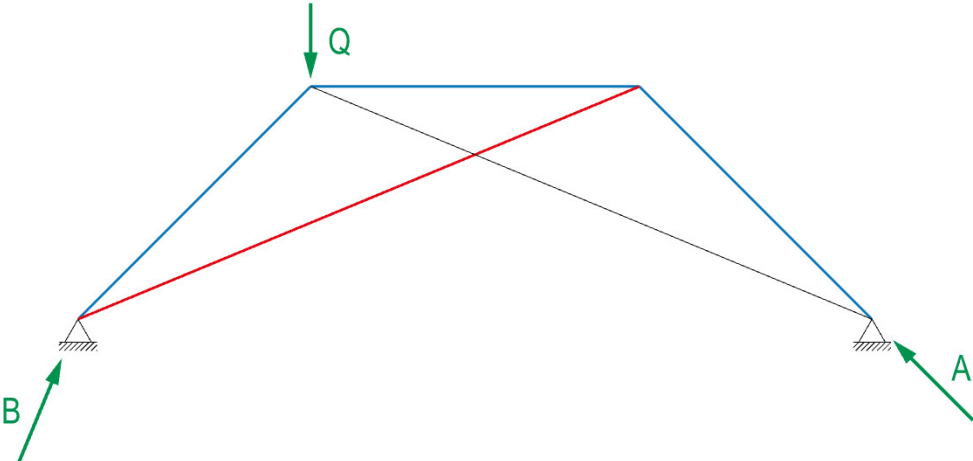

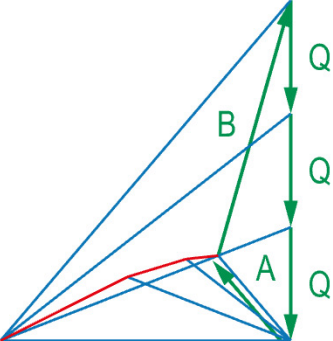
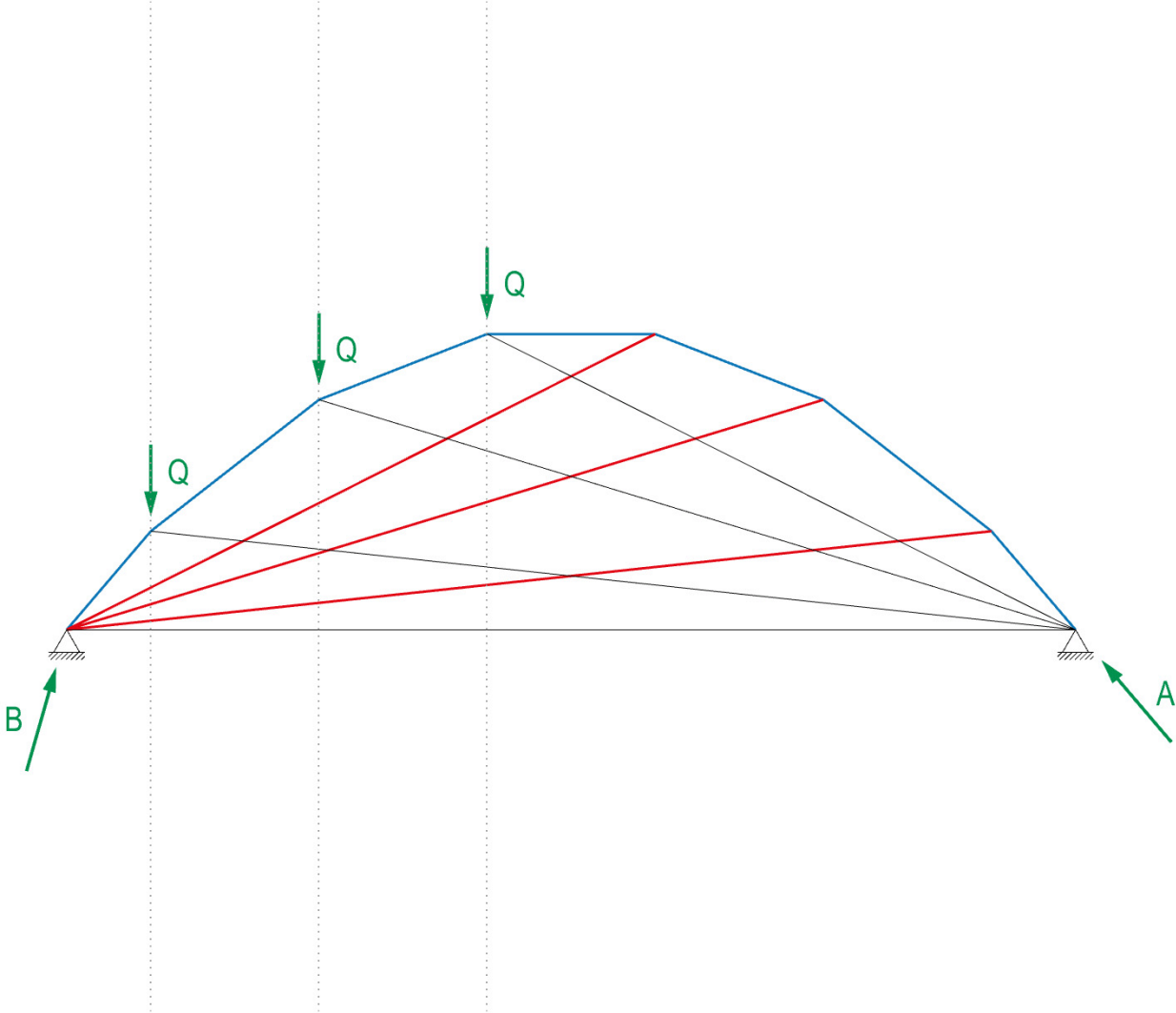



A. Pomerantsev, V. Shukhov: State warehouse GUM, Moscow, 1893



A. Pomerantsev, V. Shukhov: State warehouse GUM, Moscow, 1893

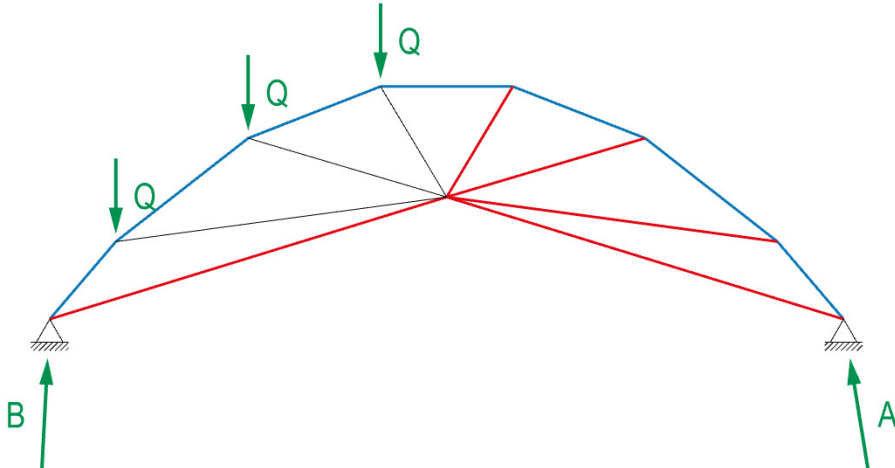
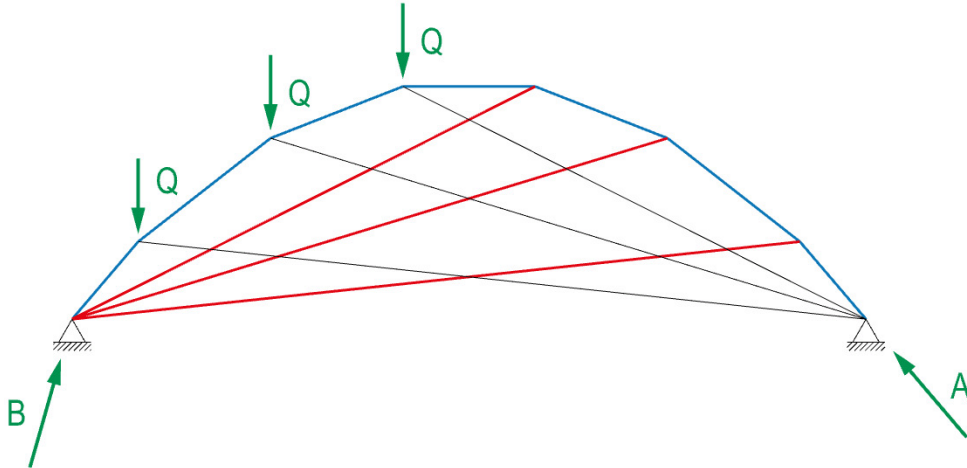

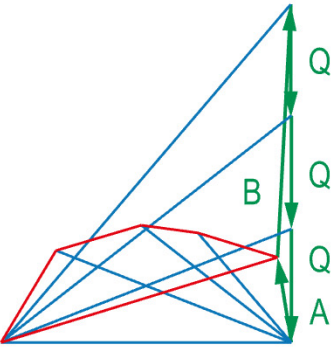
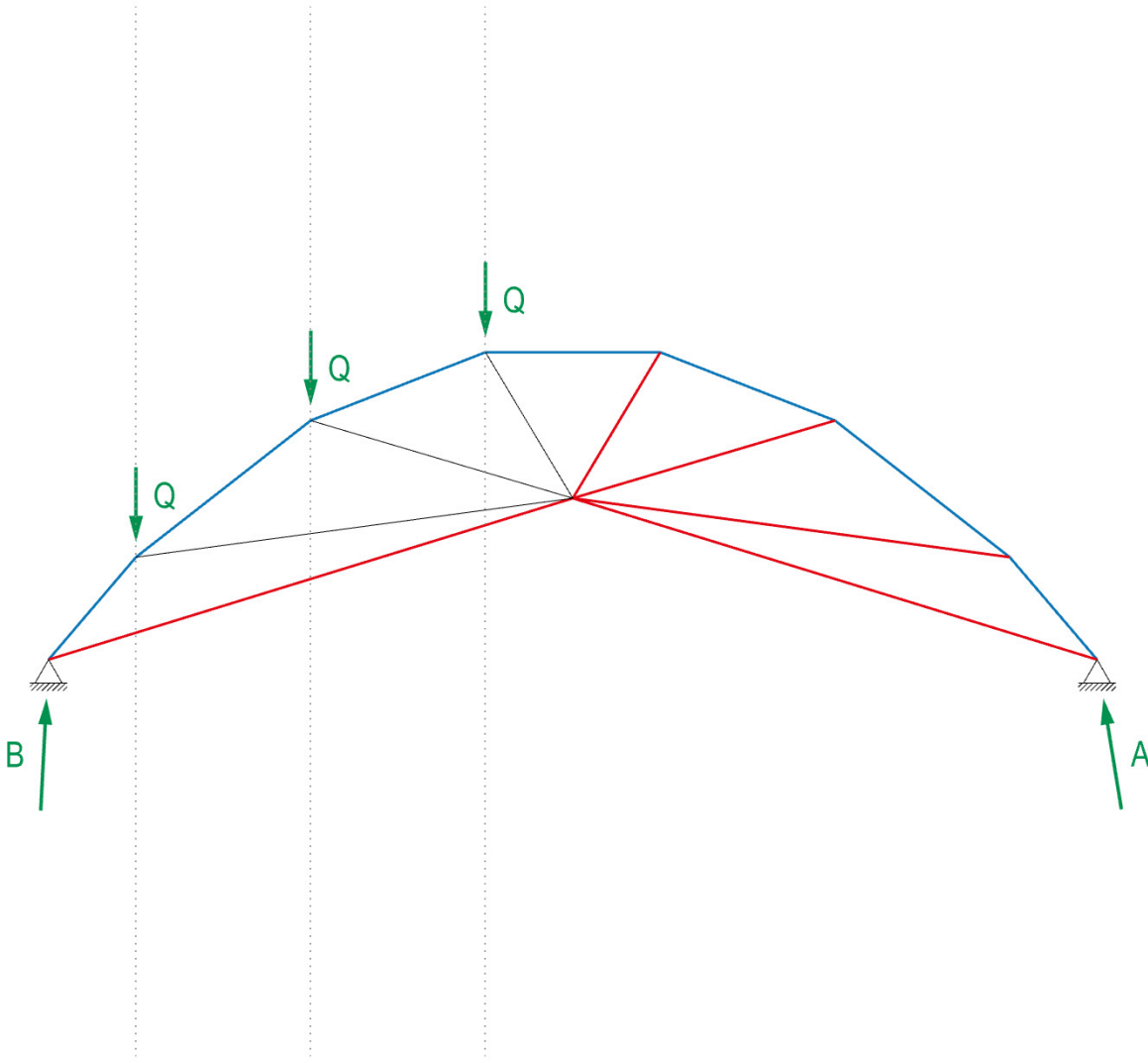



R. Brosi & Obrist and Partner, Peter Rice: Bus station Chur, 1992



R. Brosi & Obrist and Partner, Peter Rice: Bus station Chur, 1992

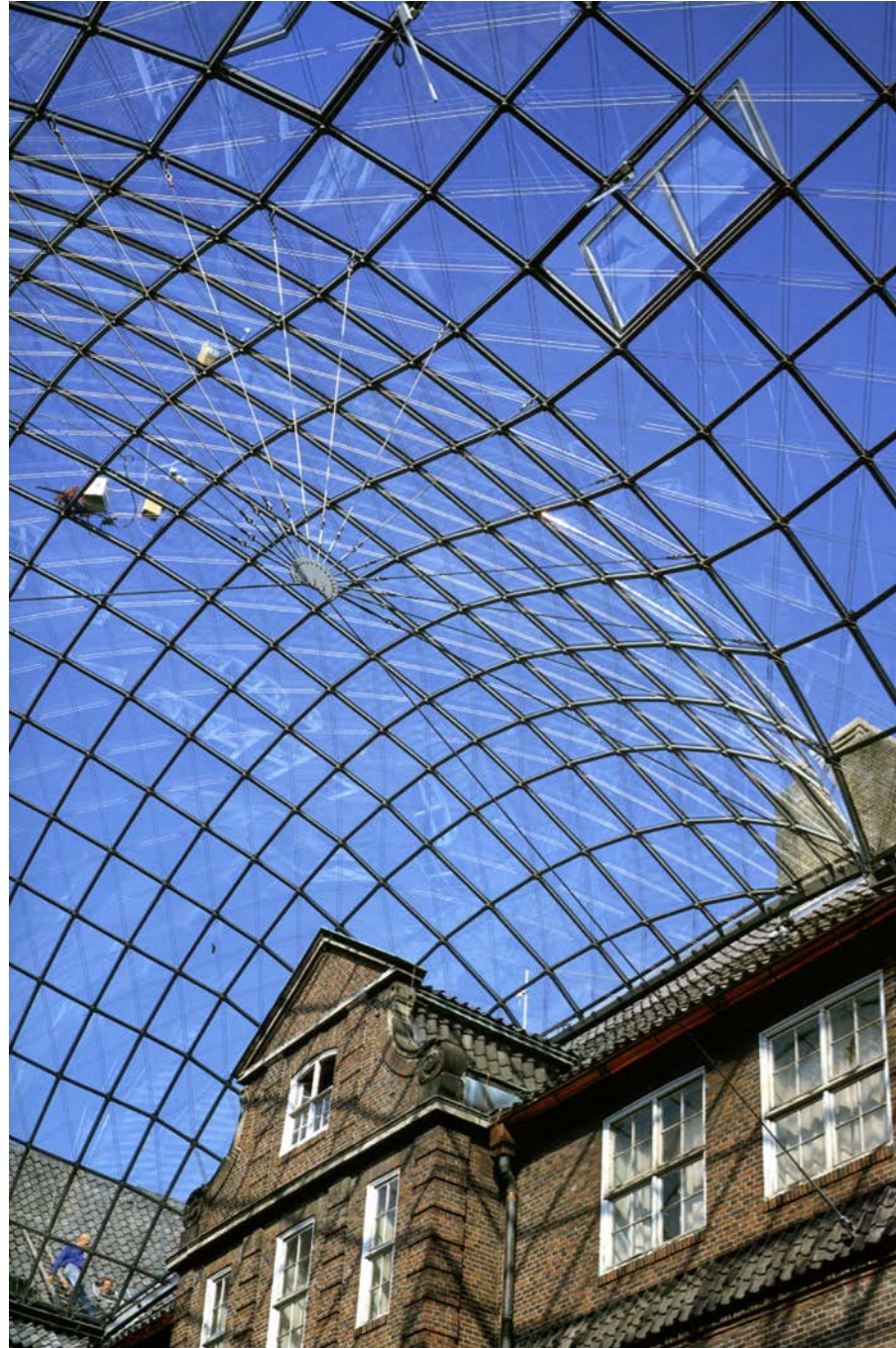

gmp Architekten, Schlaich Bergermann and Partner: Museum for history, Hamburg, 1989

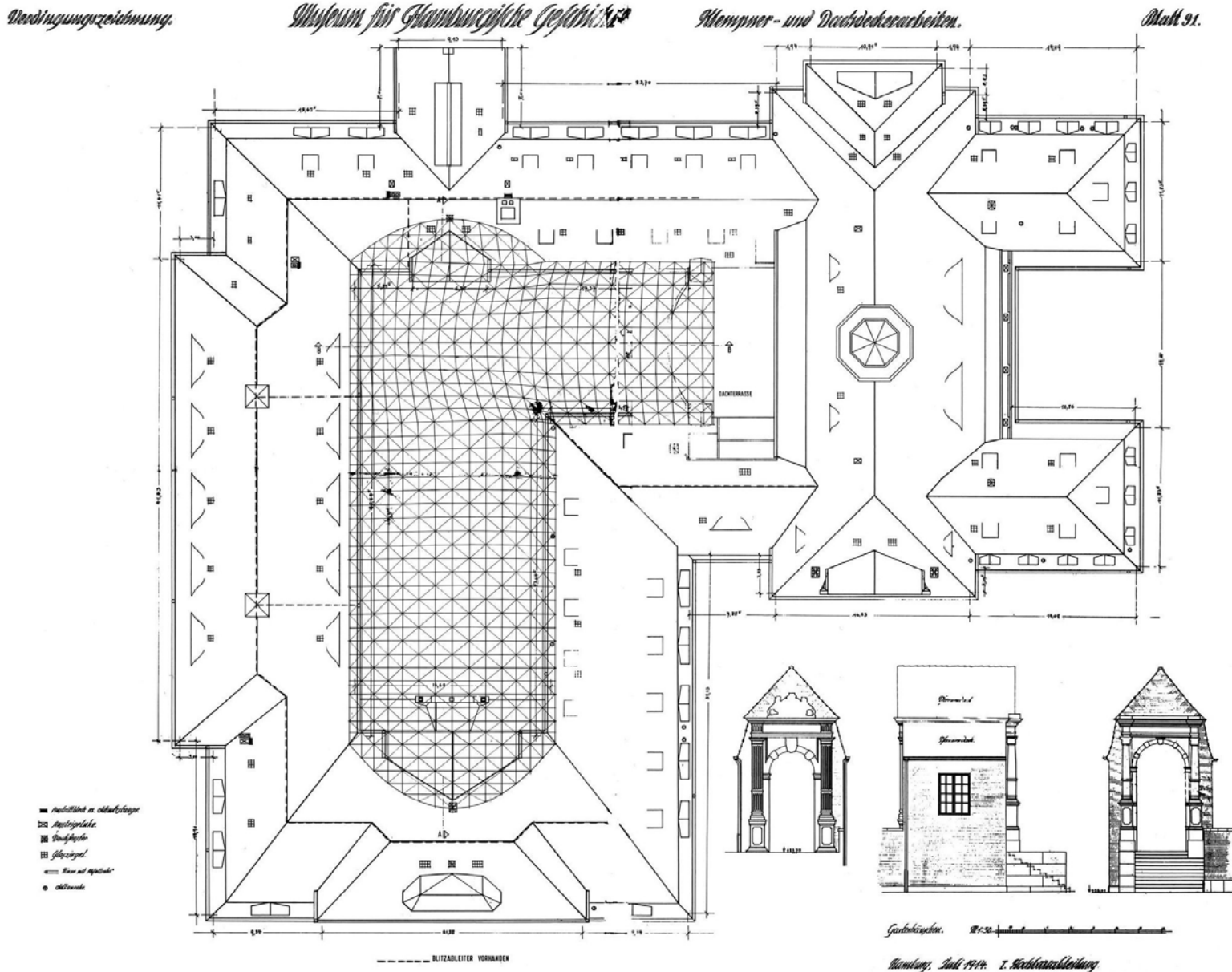

gmp Architekten, Schlaich Bergermann and Partner: Museum for history, Hamburg, 1989

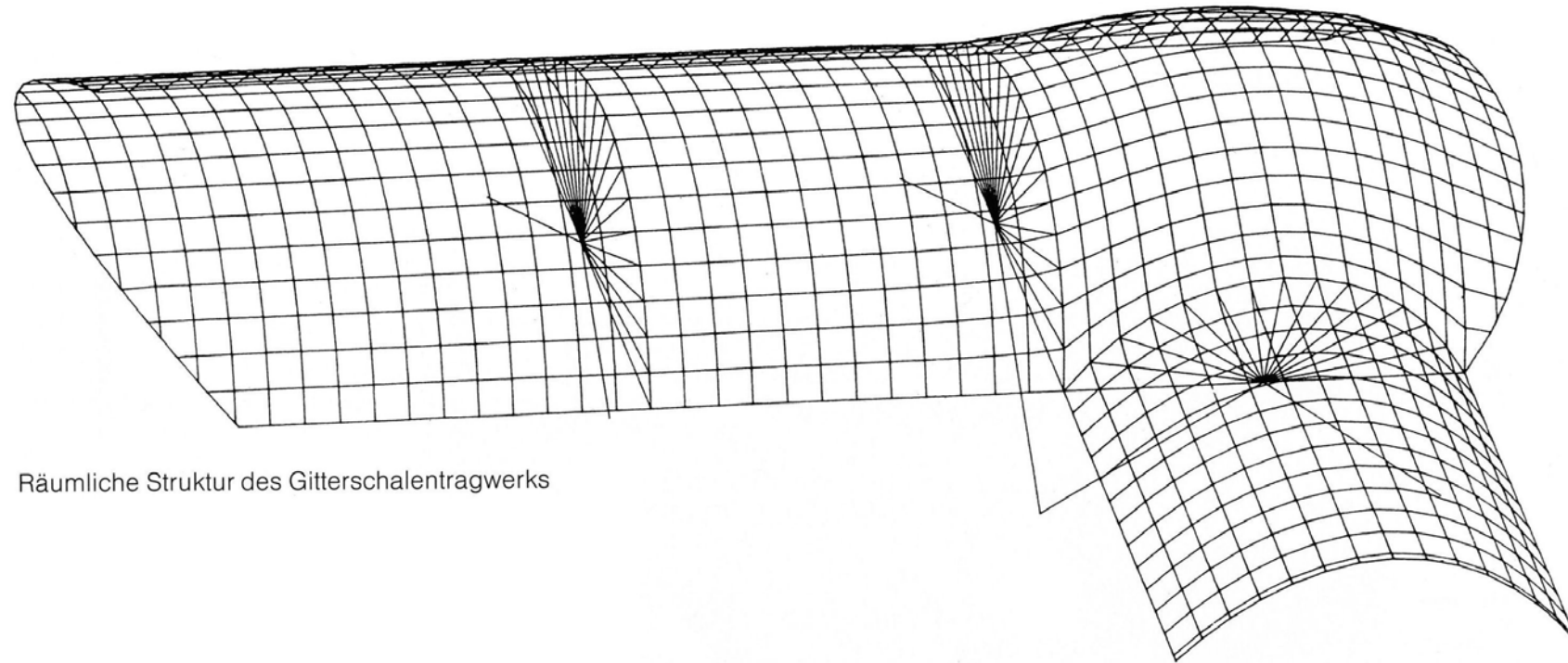

Räumliche Struktur des Gitterschalentragwerks



Frank Gehry Architects, Schlaich Bergermann and Partner: DZ Bank, Berlin, 2001

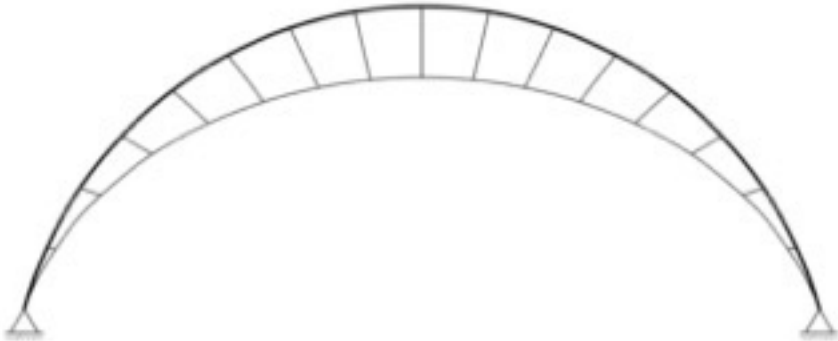

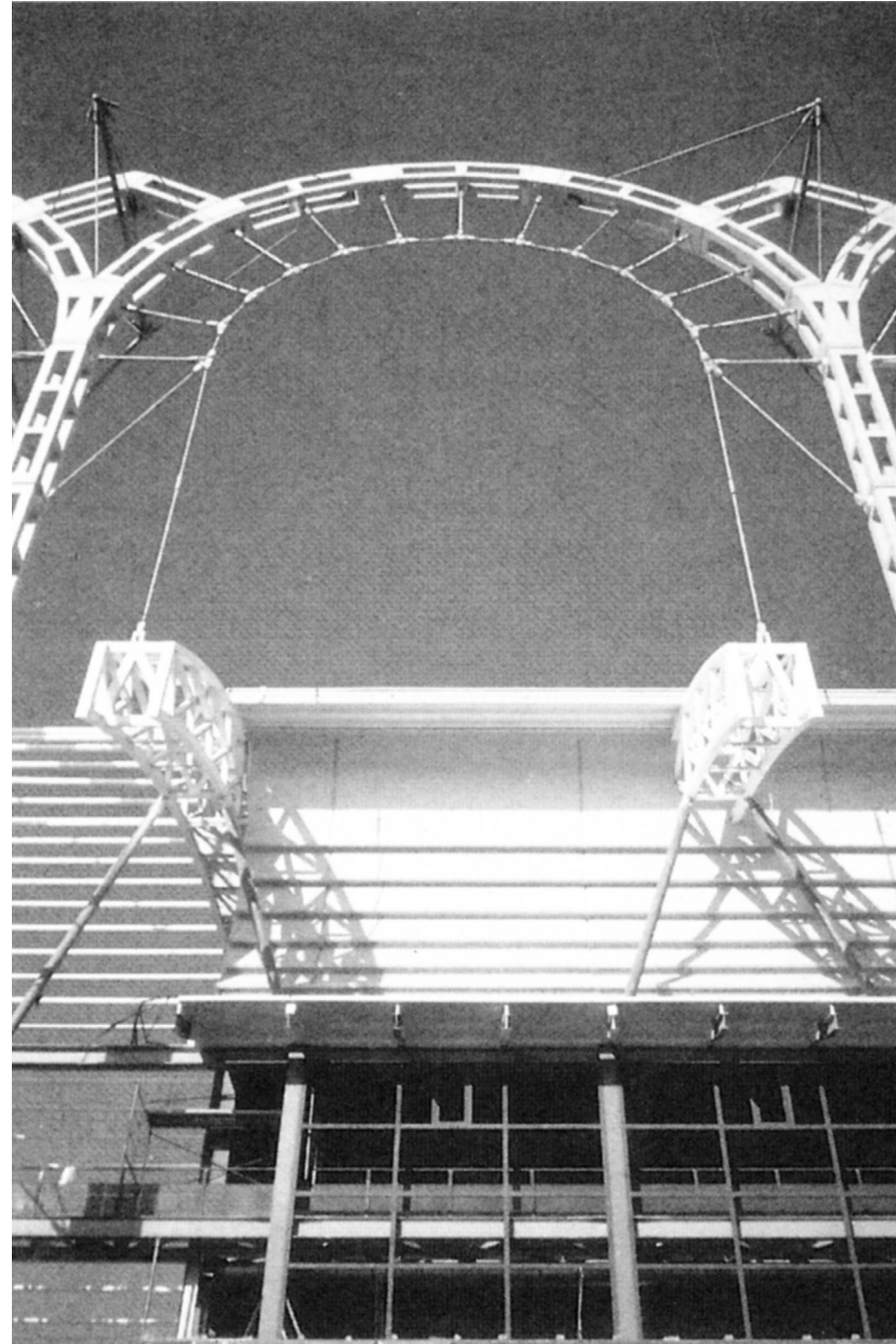

Peter Rice/ Arup: Pavilion of the Future, Sevilla, 1992

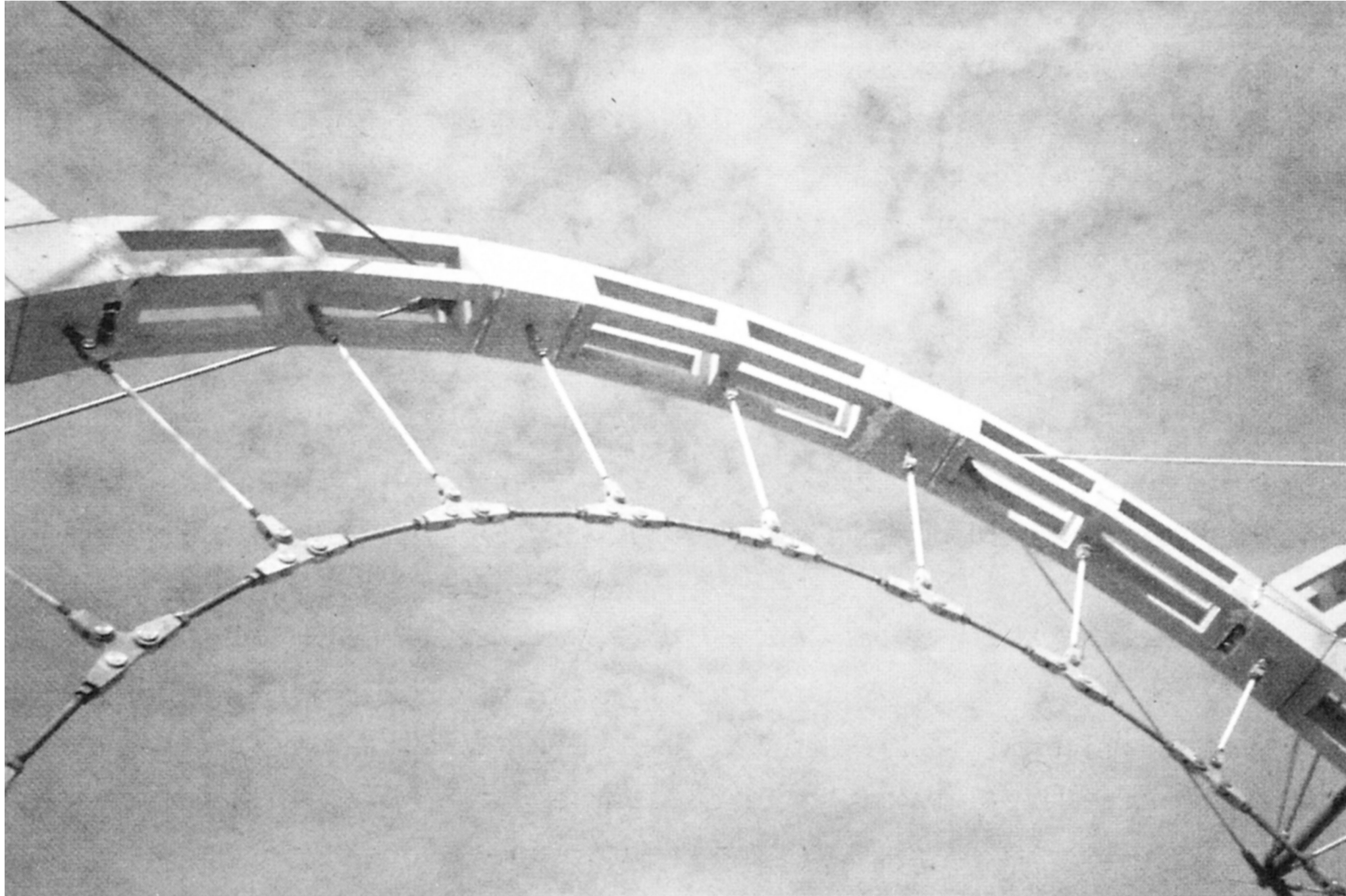

Peter Rice/ Arup: Pavilion of the Future, Sevilla, 1992

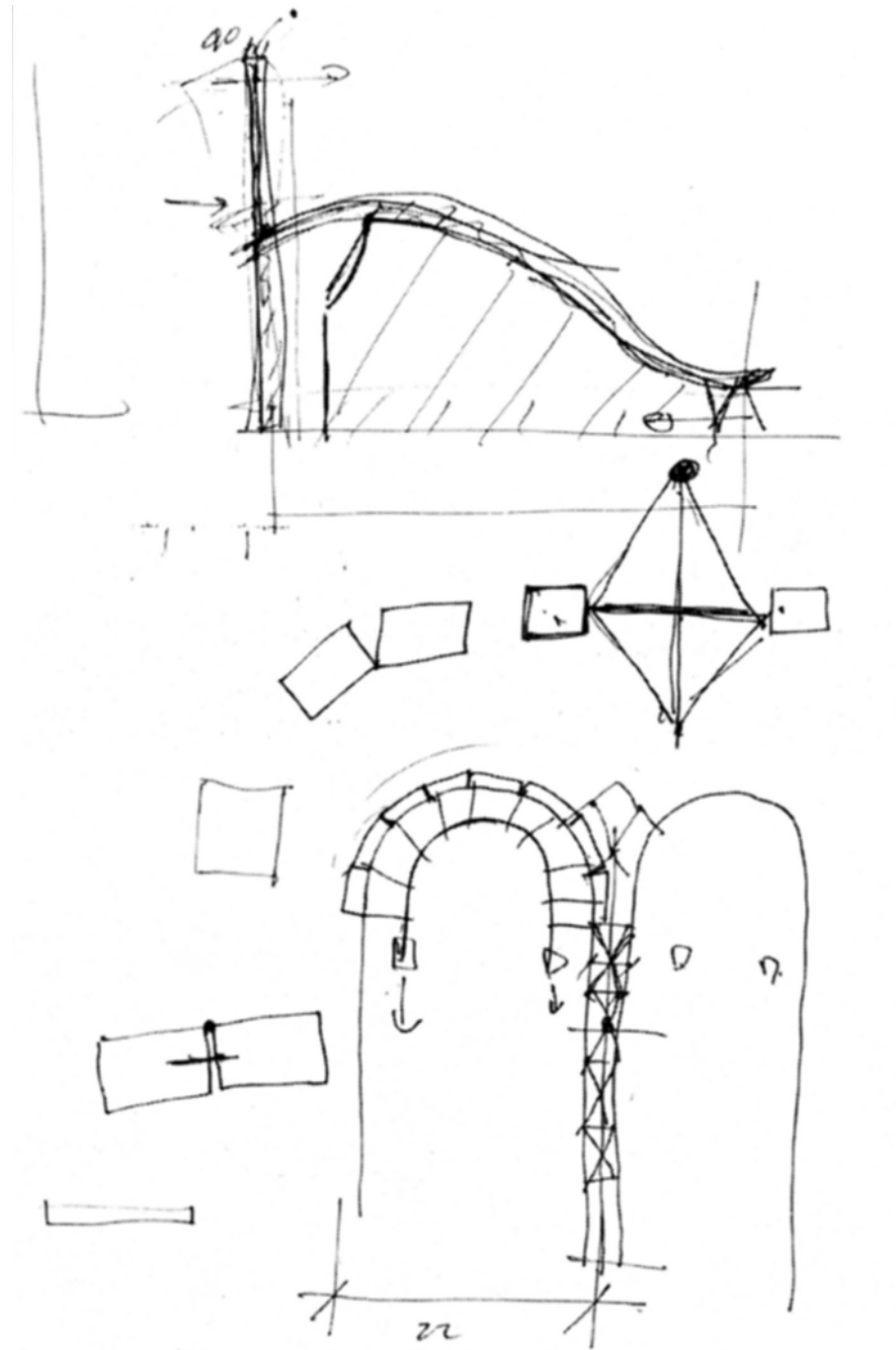

Peter Rice/ Arup: Pavilion of the Future, Sevilla, 1992



Peter Rice/ Arup: Pavilion of the Future, Sevilla, 1992

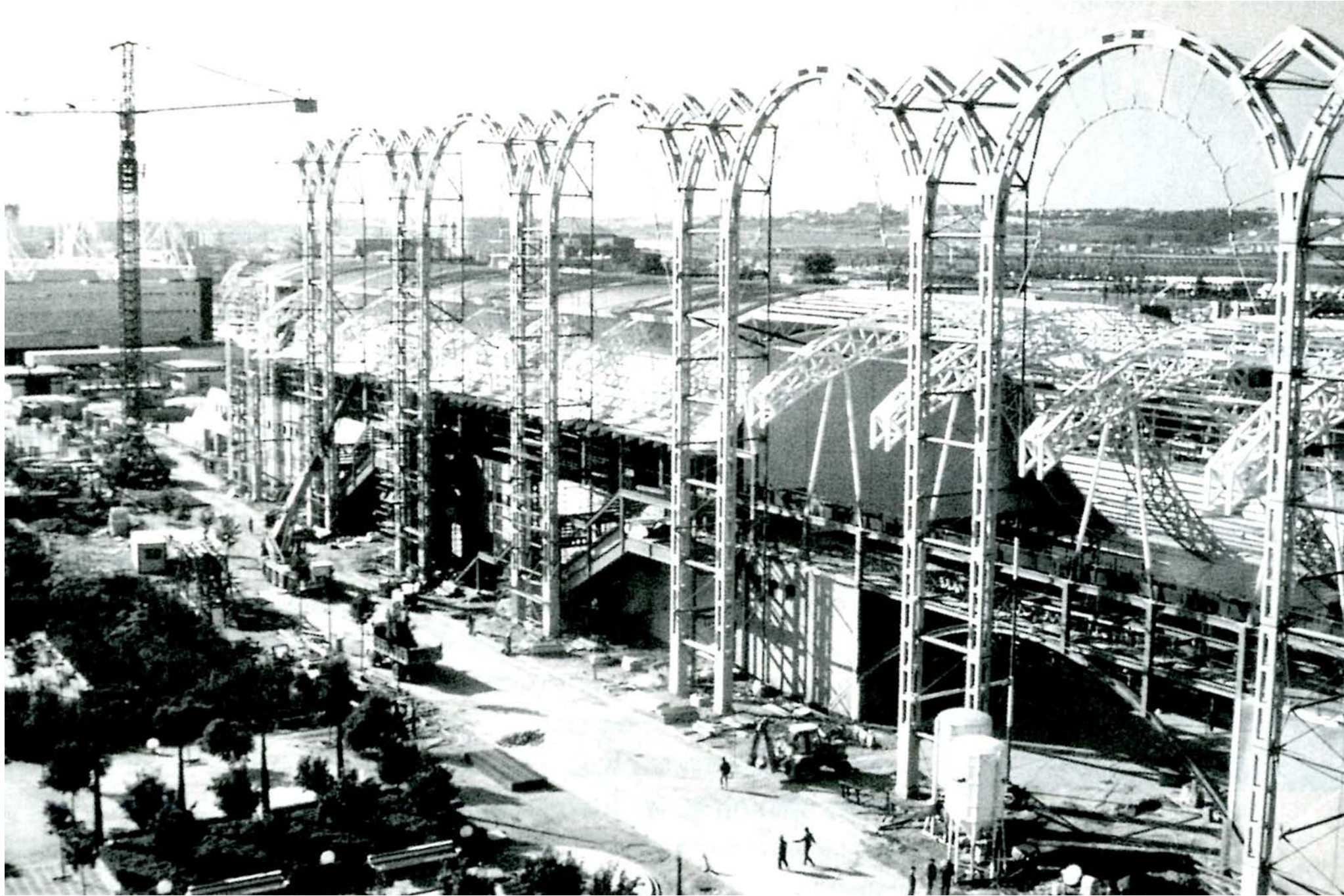

Peter Rice/ Arup: Pavilion of the Future, Sevilla, 1992

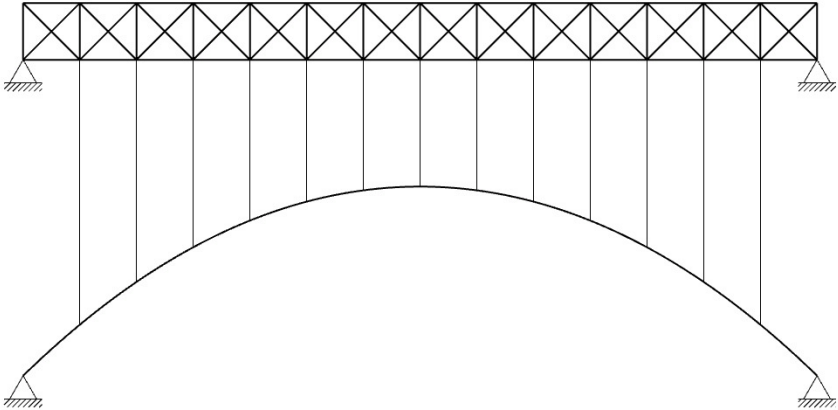

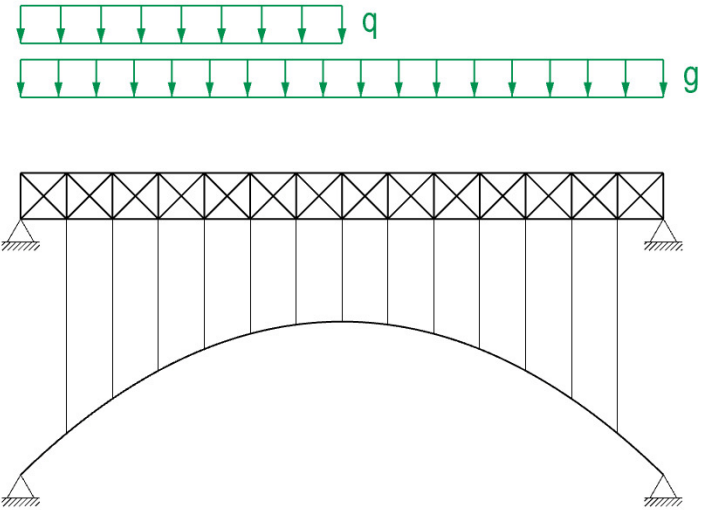

=

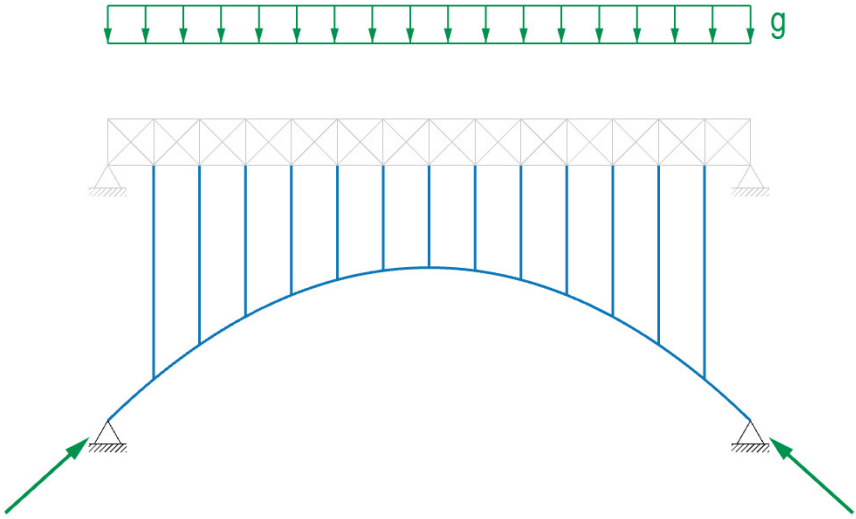

+

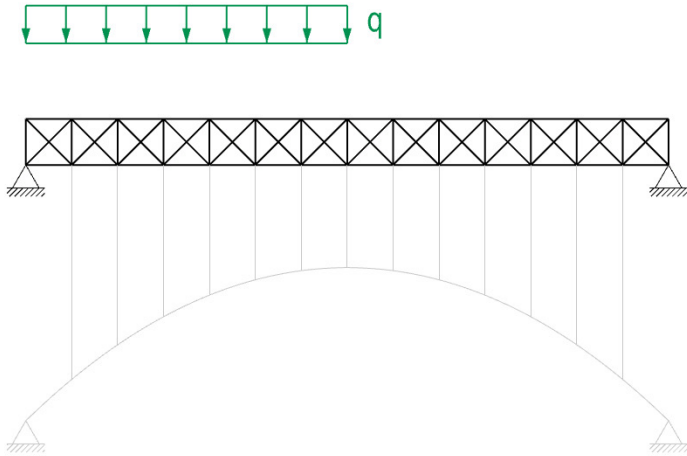



Robert Maillart: Valterschielbachbridge, Donath, 1925



Ralph Modjeski: San Francisco-Oakland Bay Bridge, San Francisco, 1936

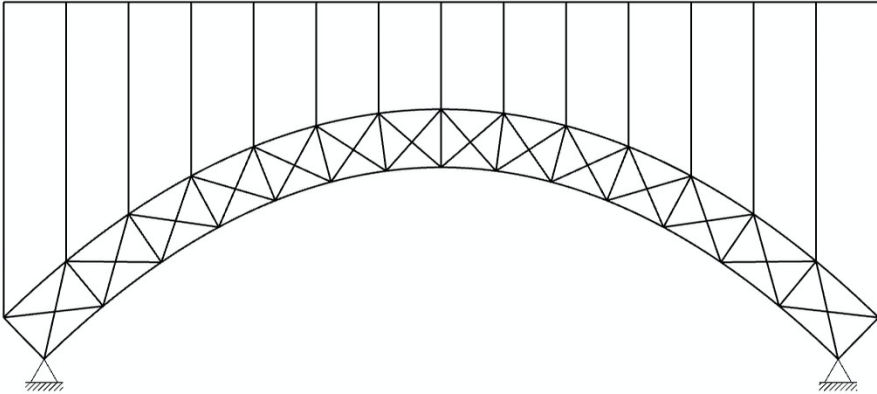



Eiffel, T. Seyring: Maria Pia bridge, Porto, 1877

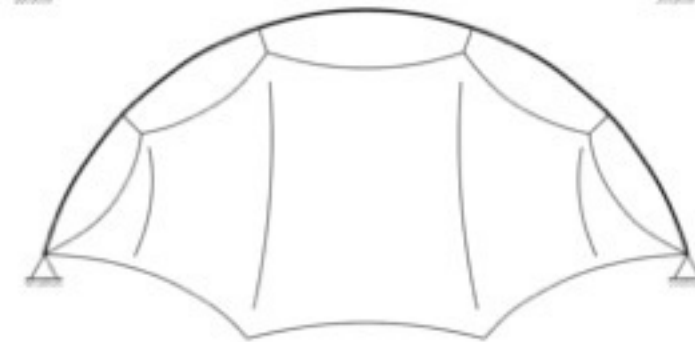
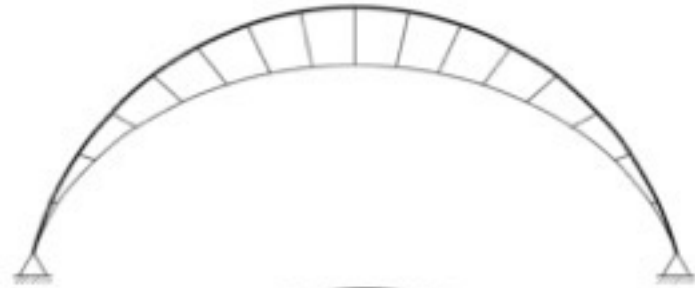
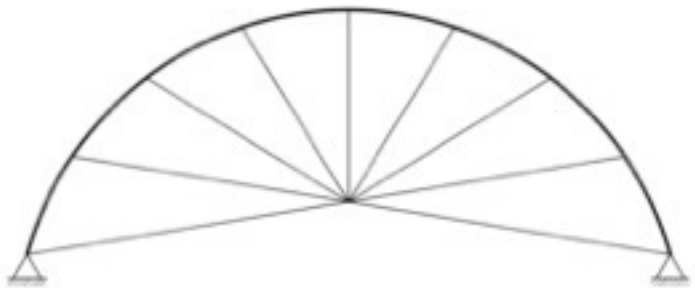
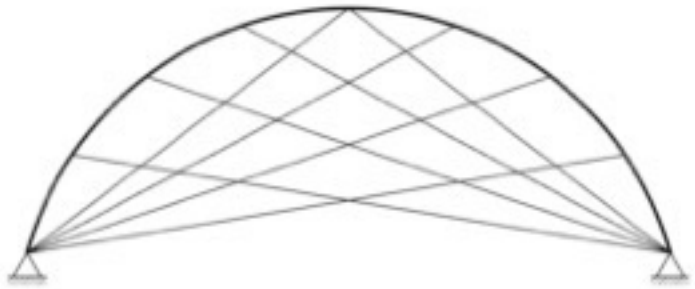

Aussteifungskabel

Stiffening cables

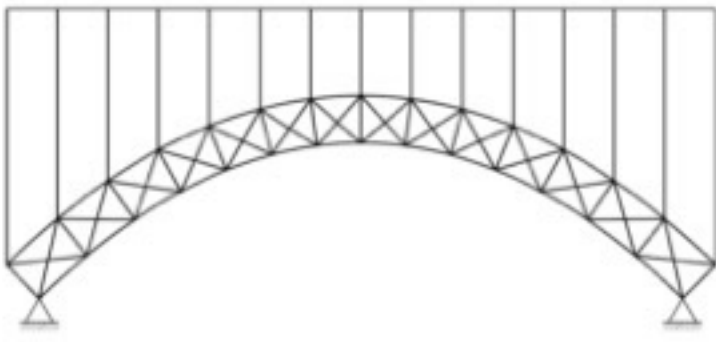
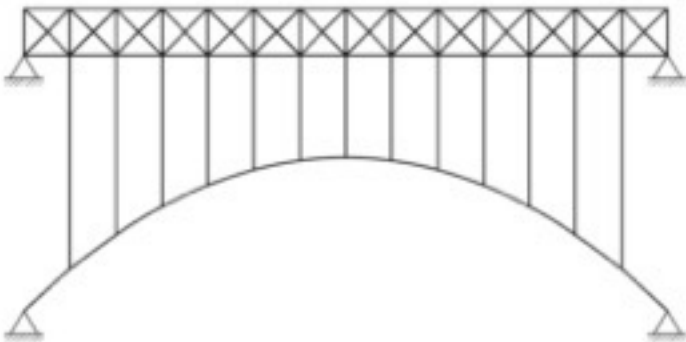

Aussteifungsbalken

Stiffening beam

Steifer Bogen

Stiff arch

Bögen

Arches

Seil und Bogen – Inversionsprinzip
Cables and arches – inversion principle

Fallbeispiel: Gotische Kathedrale
Case study: Gothic cathedral

Aussteifungskonzepte
Concepts for stiffening

>> Stützlinien
Thrust lines

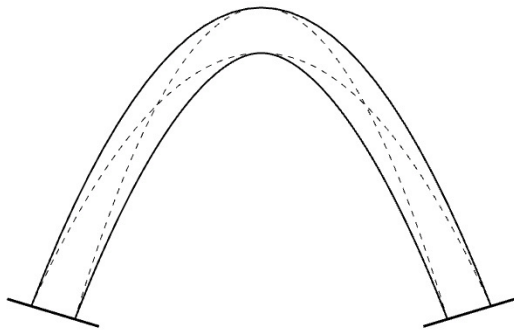

Bogen ohne Gelenke
Arches without hinges

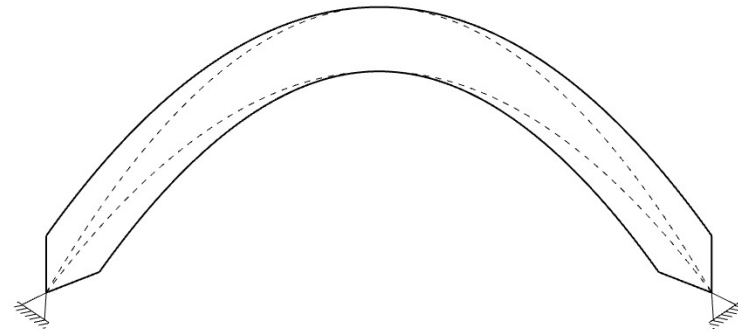

Zwei-gelenk Bogen
Arches with two hinges

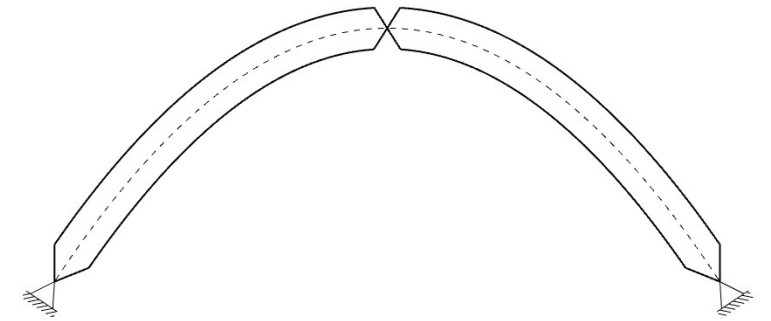

Drei-gelenk Bogen
Arches with three hinges

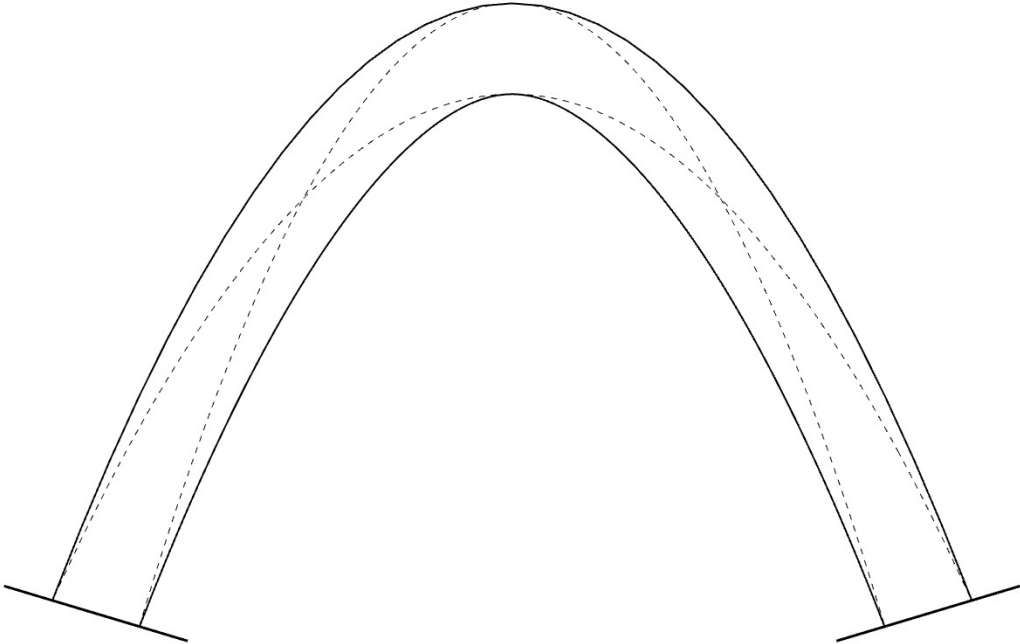

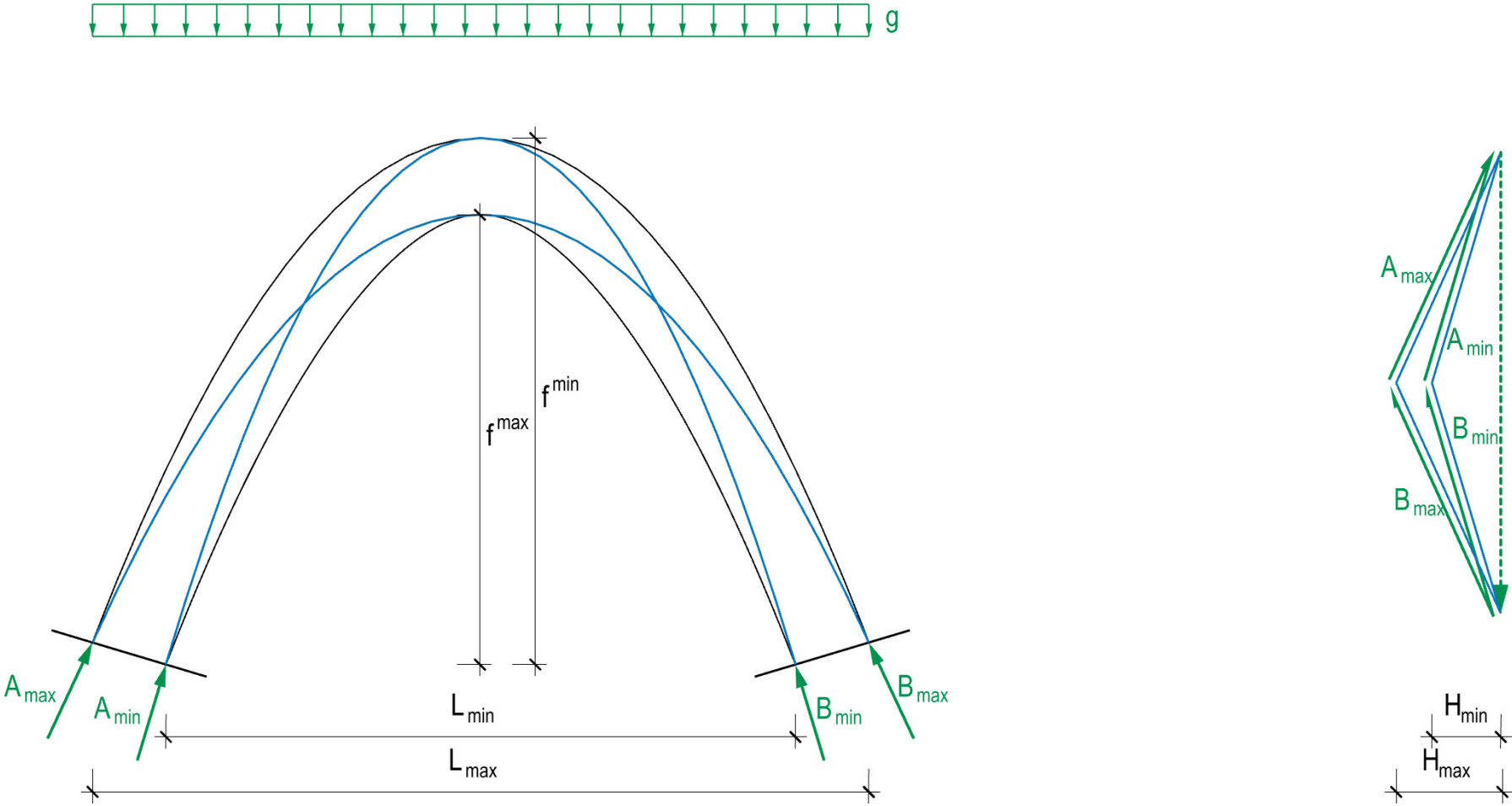



Taq-i Kisra Palast (Ayvan-e Kasra), Asbanbar, near Baghdad, 550 n.Chr.



Renzo Piano, Arup: Chiesa di Padre Pio, San Giovanni Rotondo, 2004

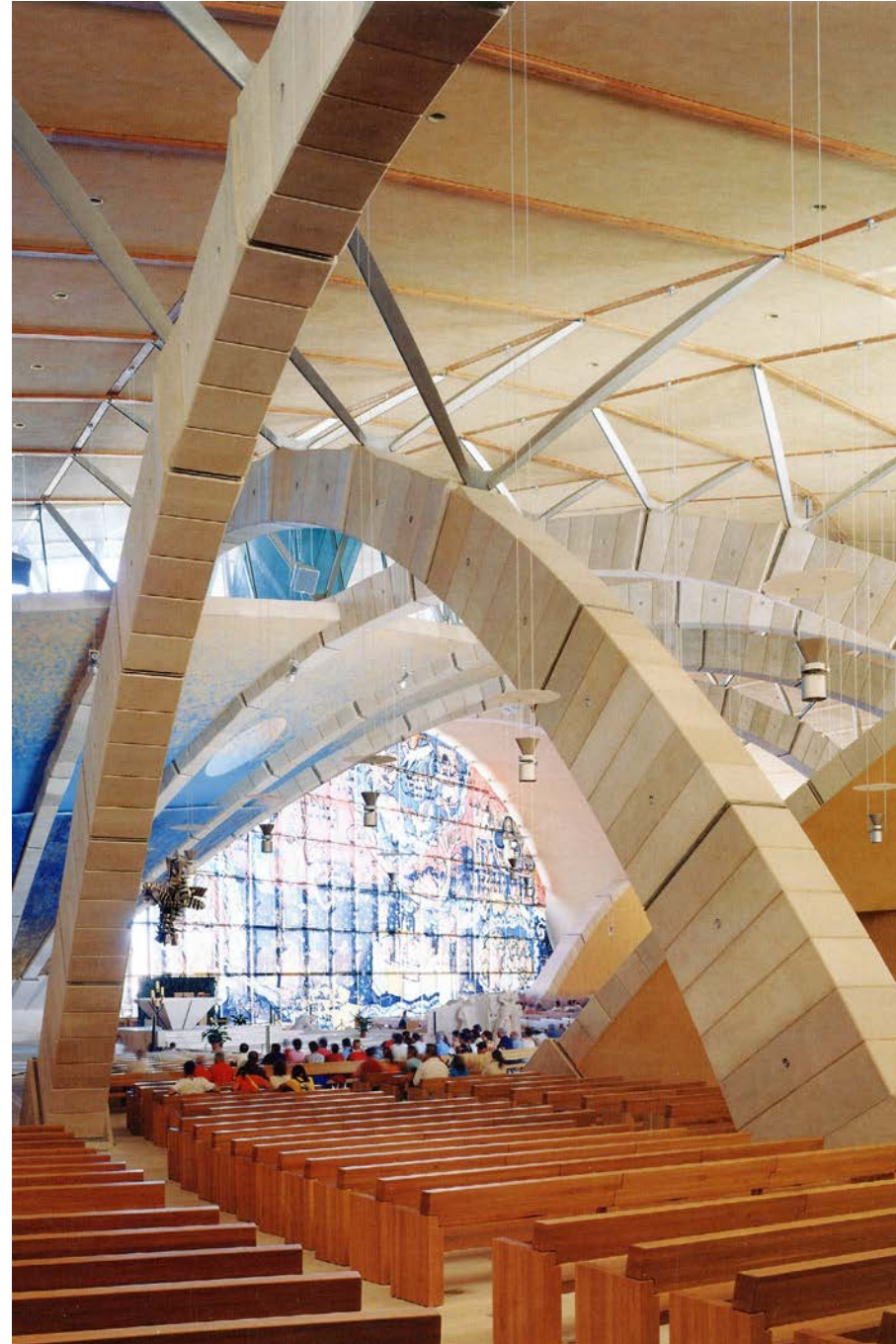

Renzo Piano, Arup: Chiesa di Padre Pio, San Giovanni Rotondo, 2004



Renzo Piano, Arup: Chiesa di Padre Pio, San Giovanni Rotondo, 2004

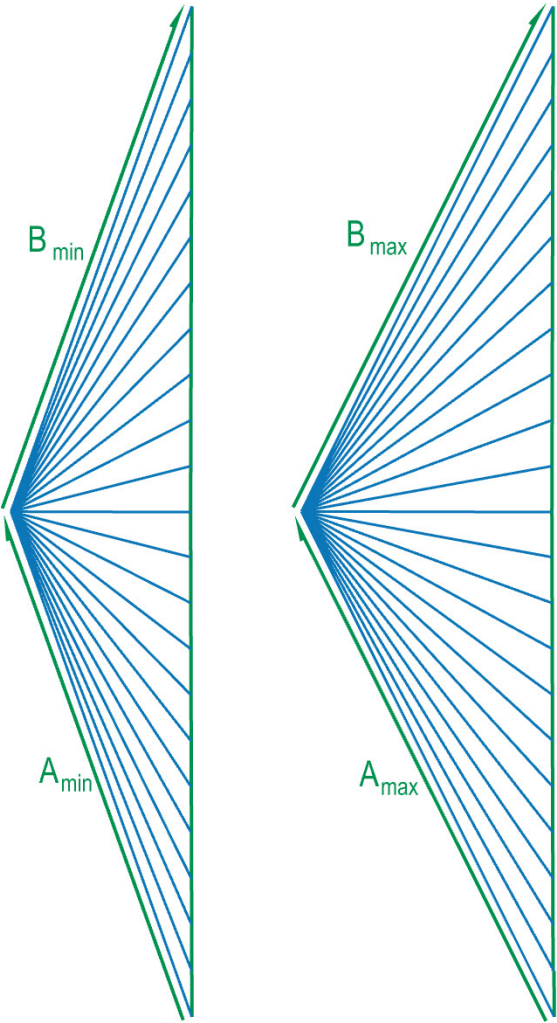
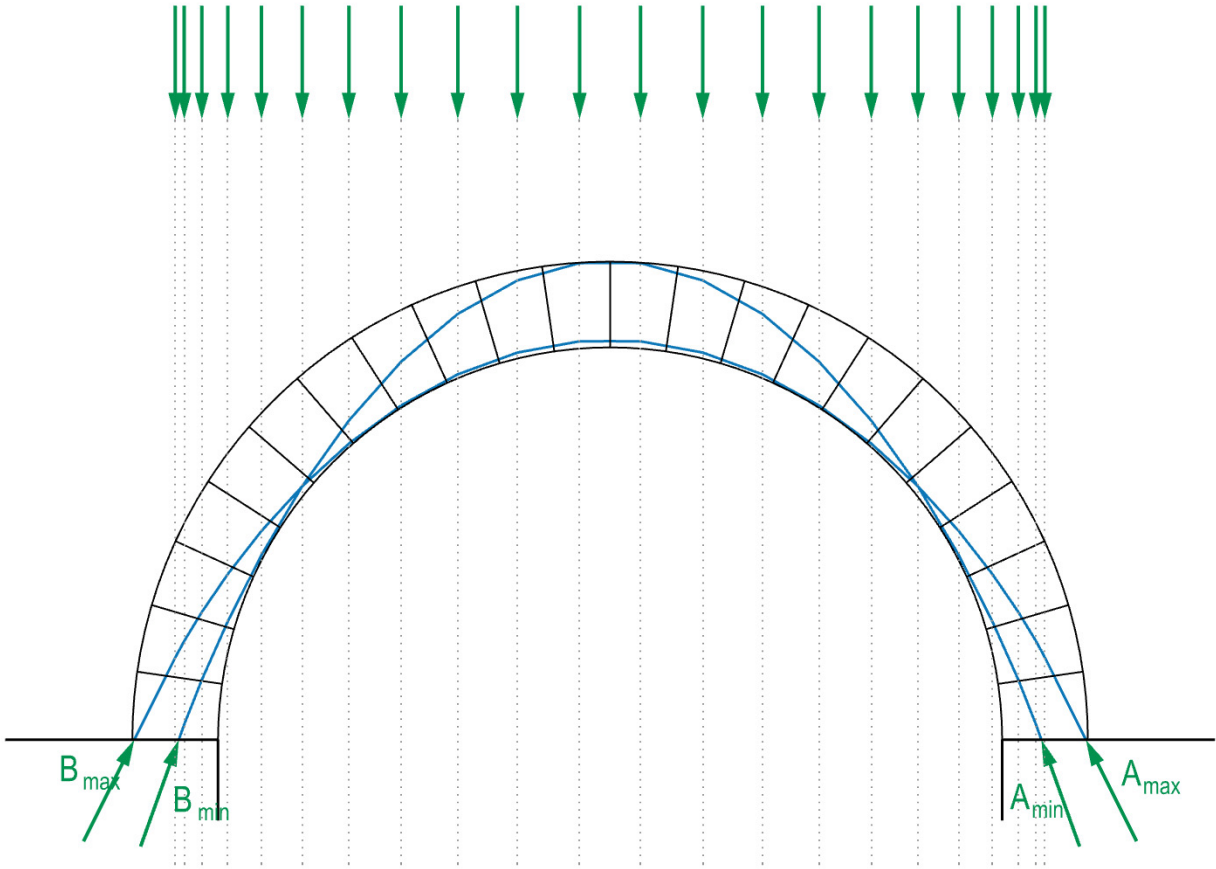

eQ: Minimum and maximum thrust line

Form Diagram

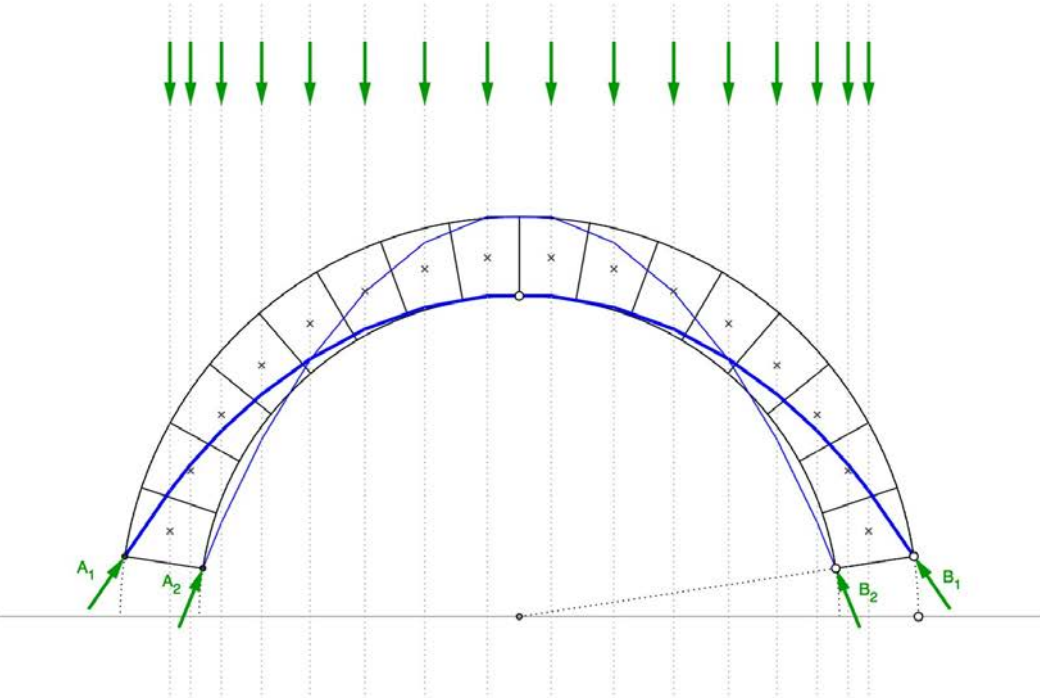

Force Diagram

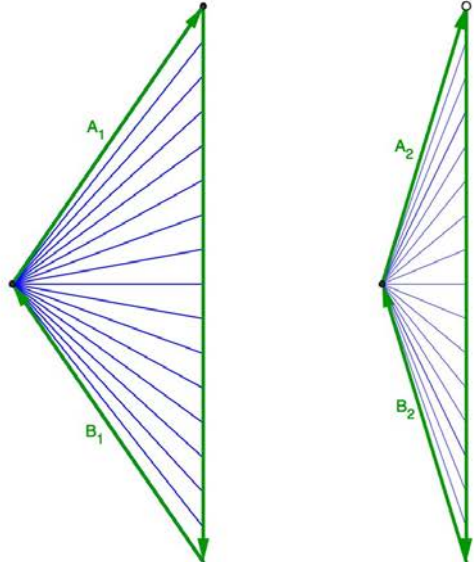

<http://www.block.arch.ethz.ch/eq/drawing/view/16>

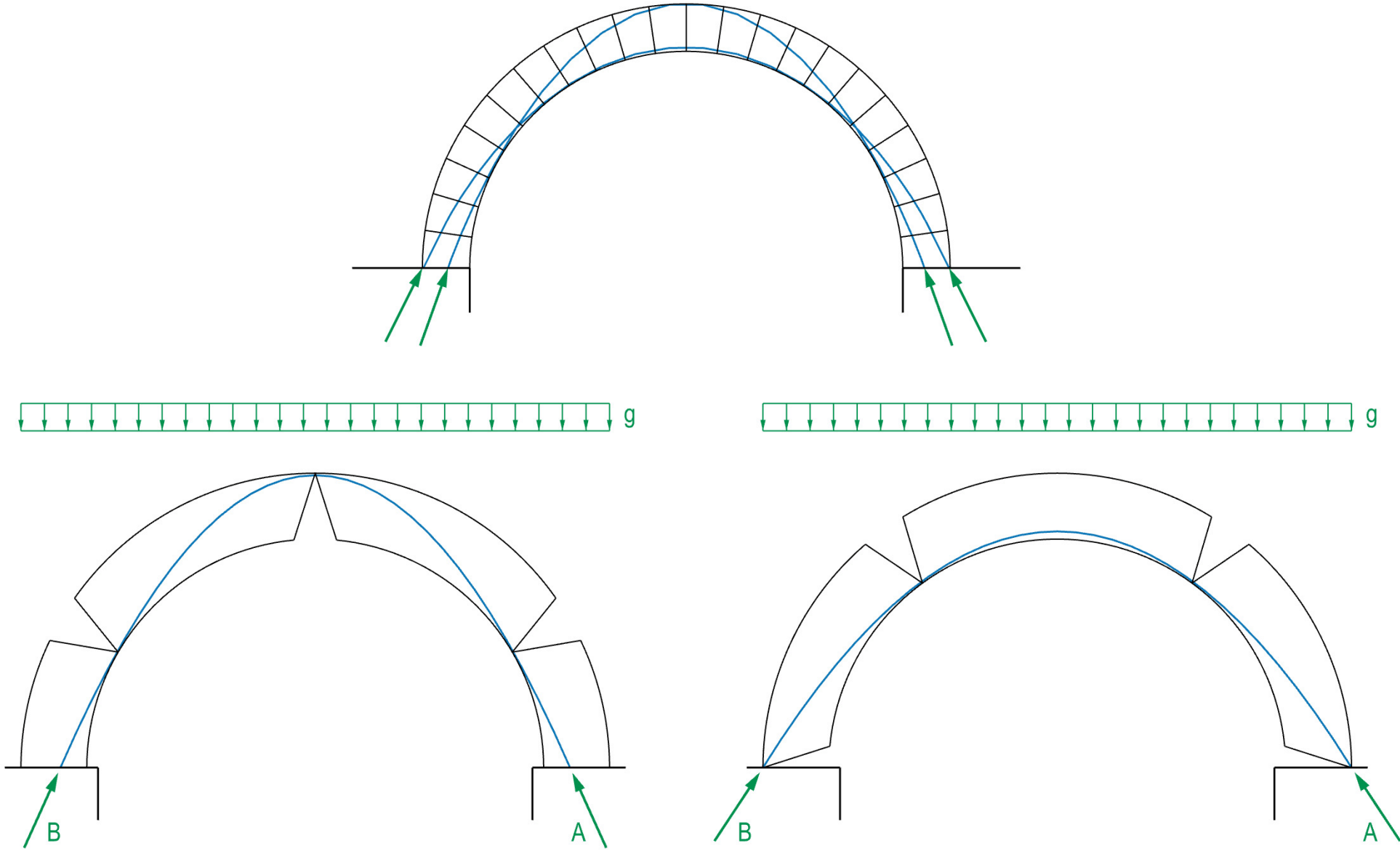

eQ: Masonry arch on spreading supports

Form Diagram

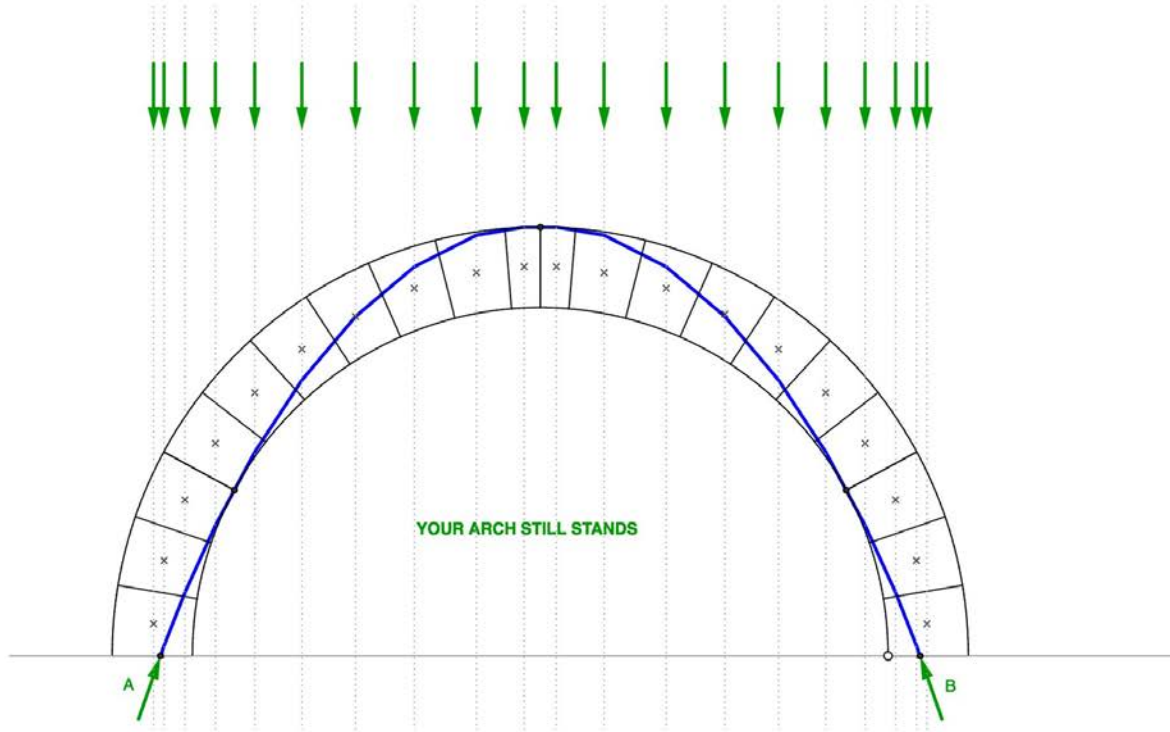

Force Diagram

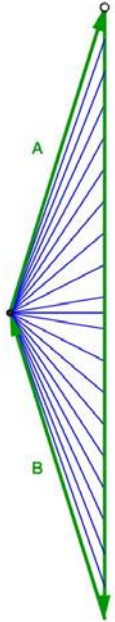

<http://www.block.arch.ethz.ch/eq/drawing/view/17>



Vezelay Abbey, Burgundy, France, 11th century

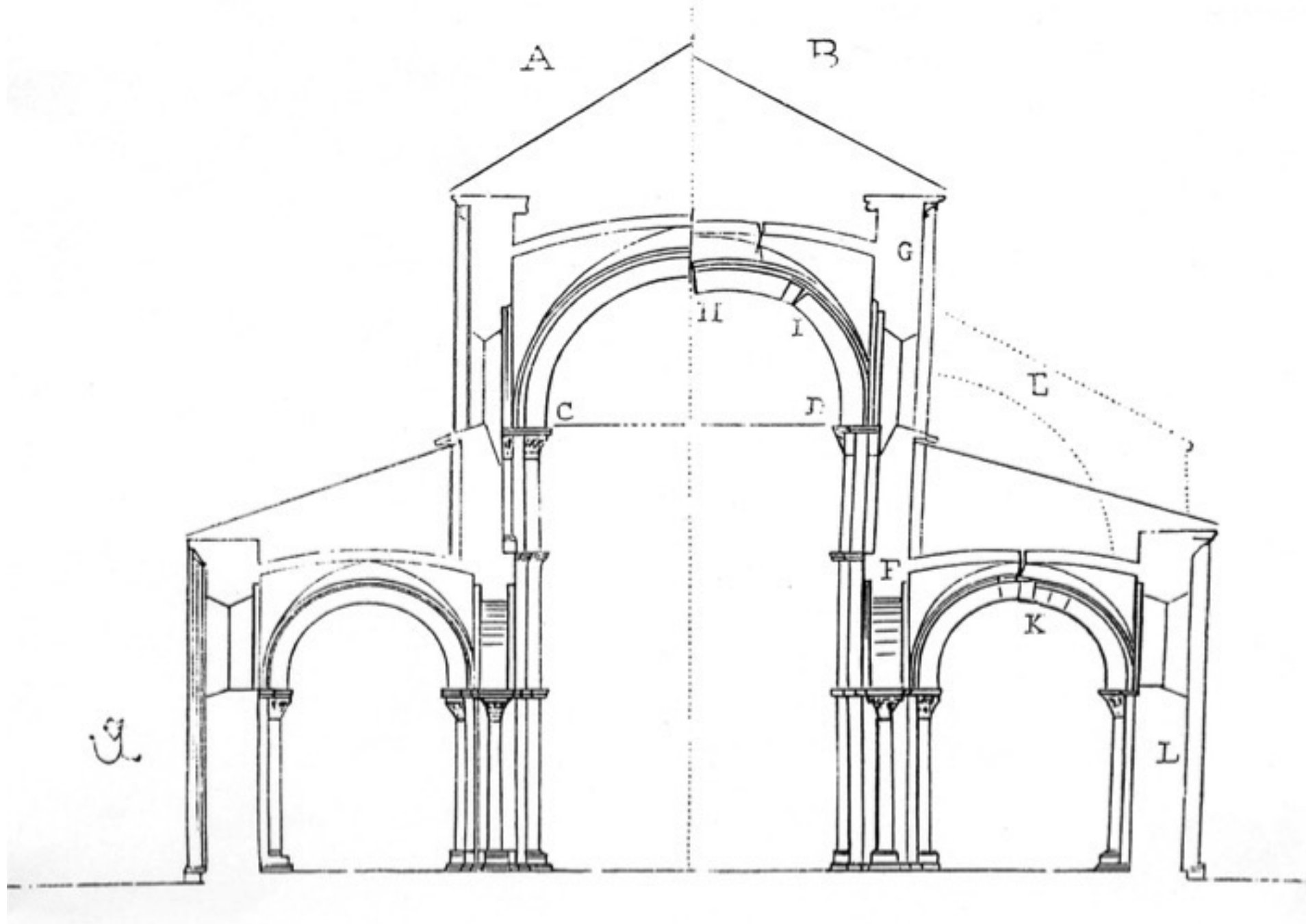

Vezelay Abbey, Burgundy, France, 11th century; Drawing Viollet-le-Duc

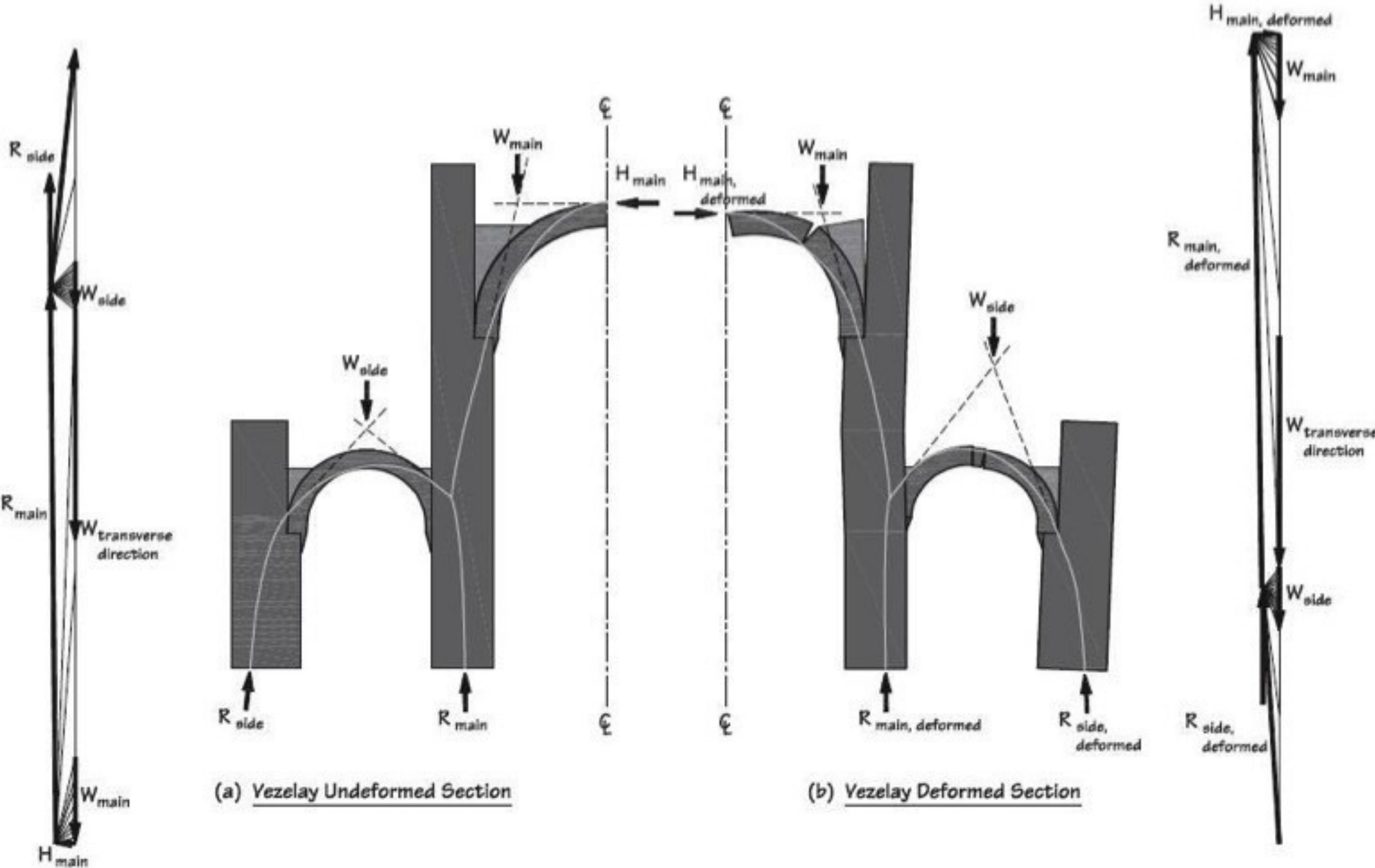

Vezelay Abbey, Burgundy, France, 11th century

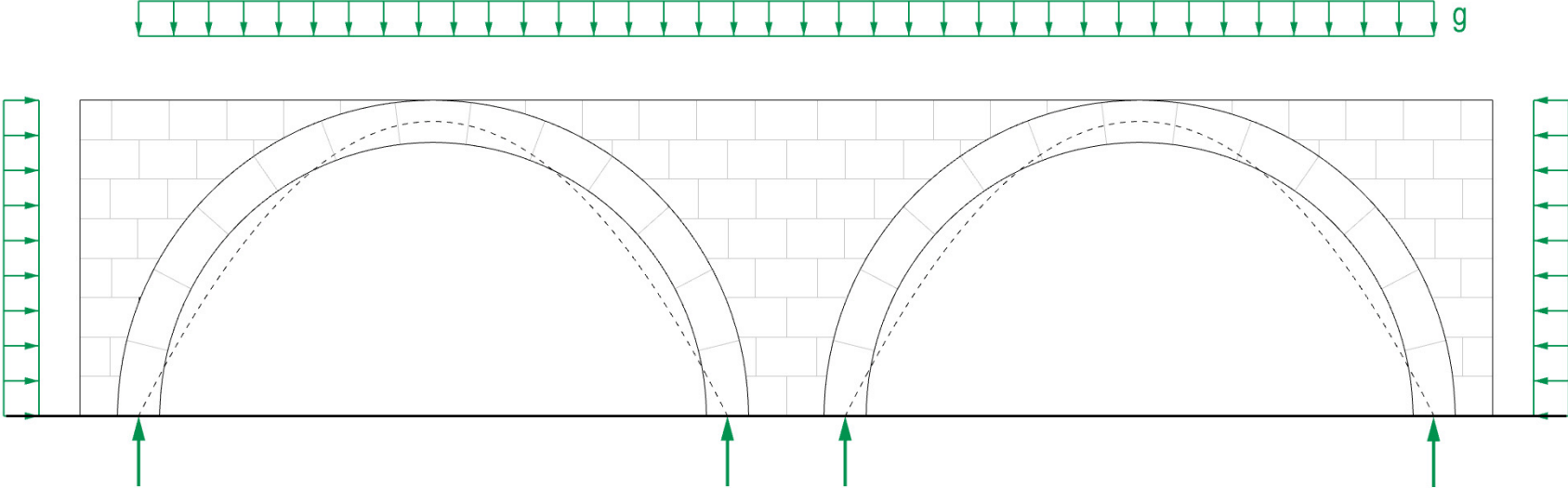

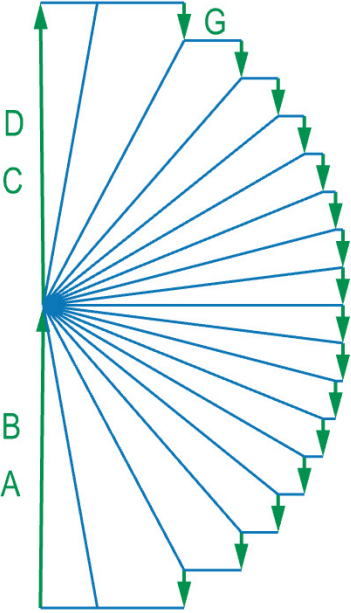
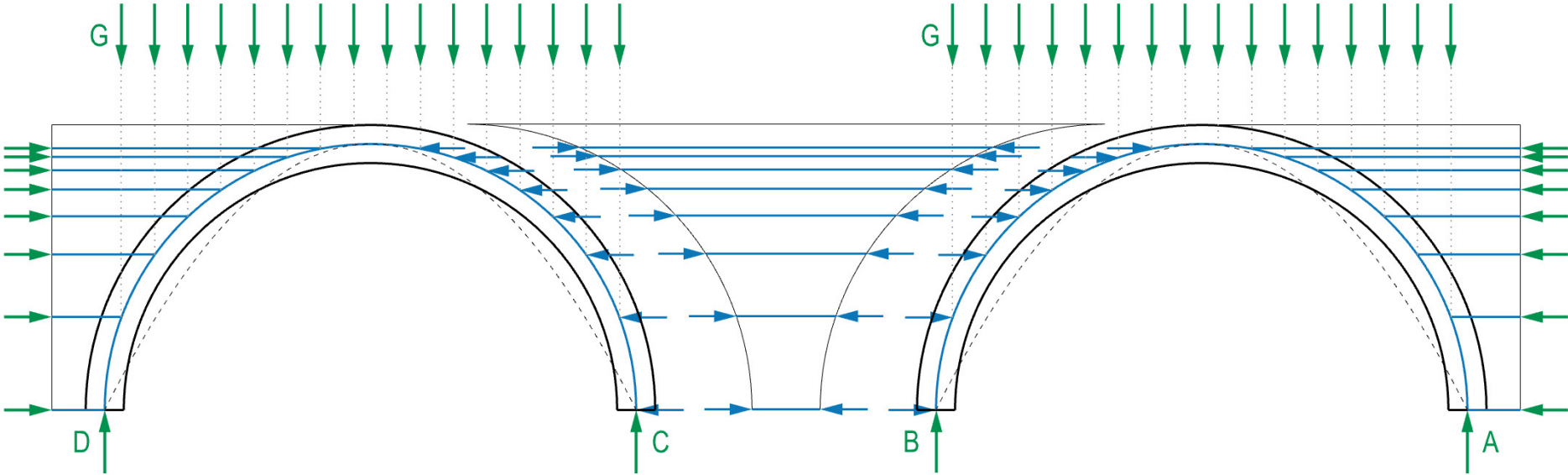



Pont du Gard, Nimes, France, 1st century AD



L. Laurana: Palazzo Ducale, Urbino, 1472

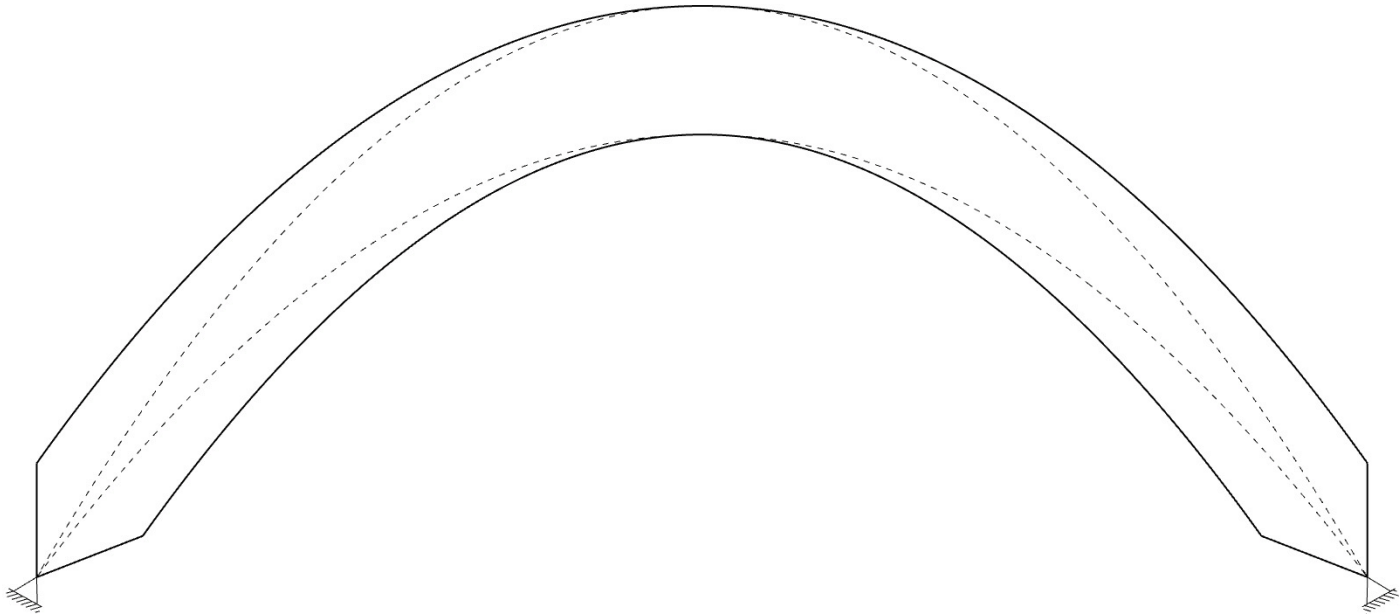

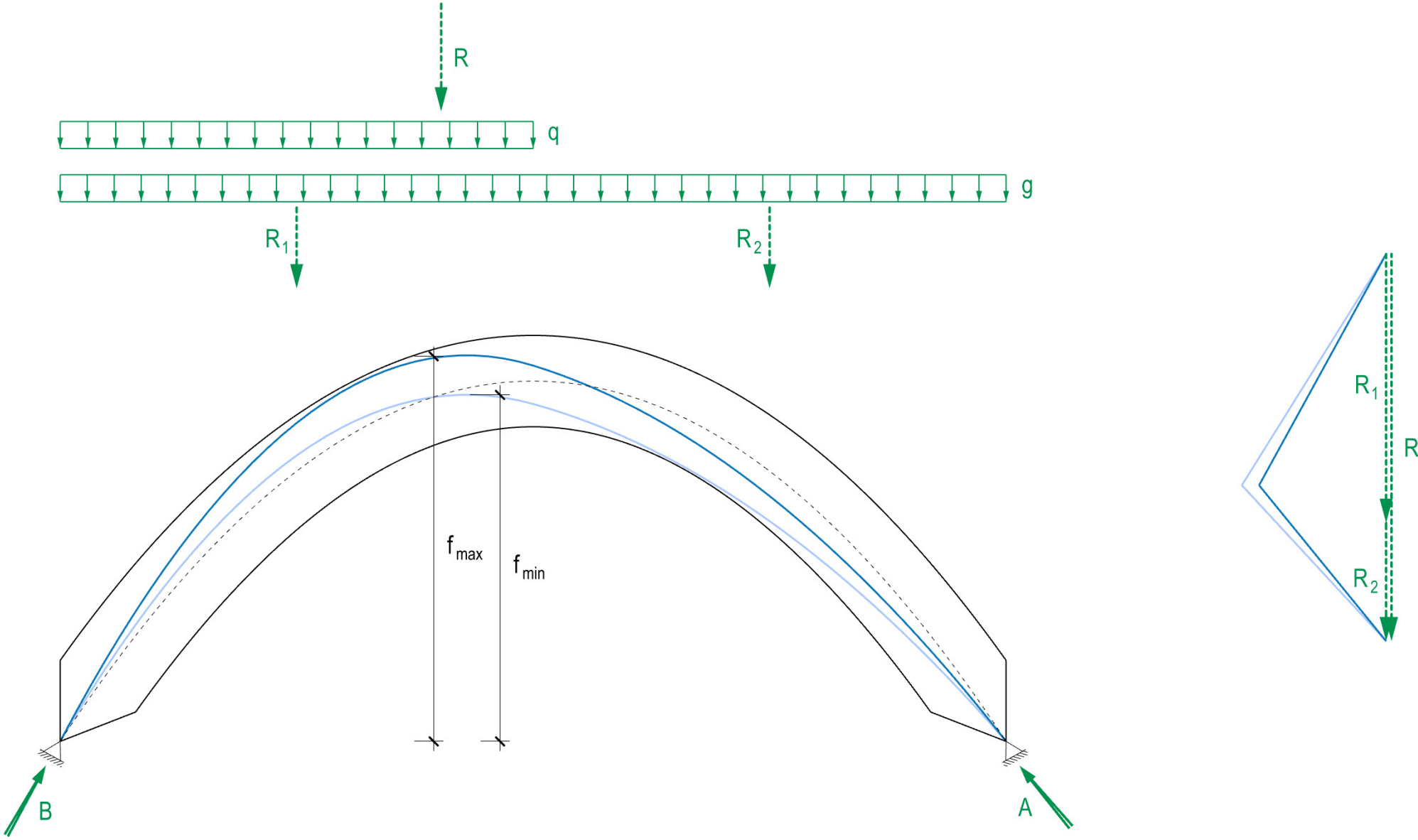



Gustave Eiffel, M. Koechlin: Viadukt Garabit, Ruynes, 1884



Gustave Eiffel, M. Koechlin: Viadukt Garabit, Ruynes, 1884

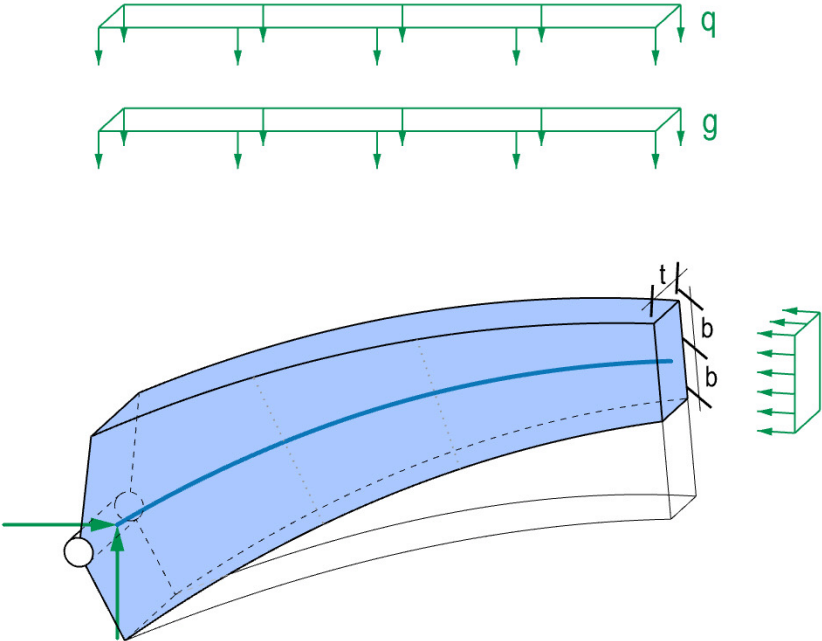

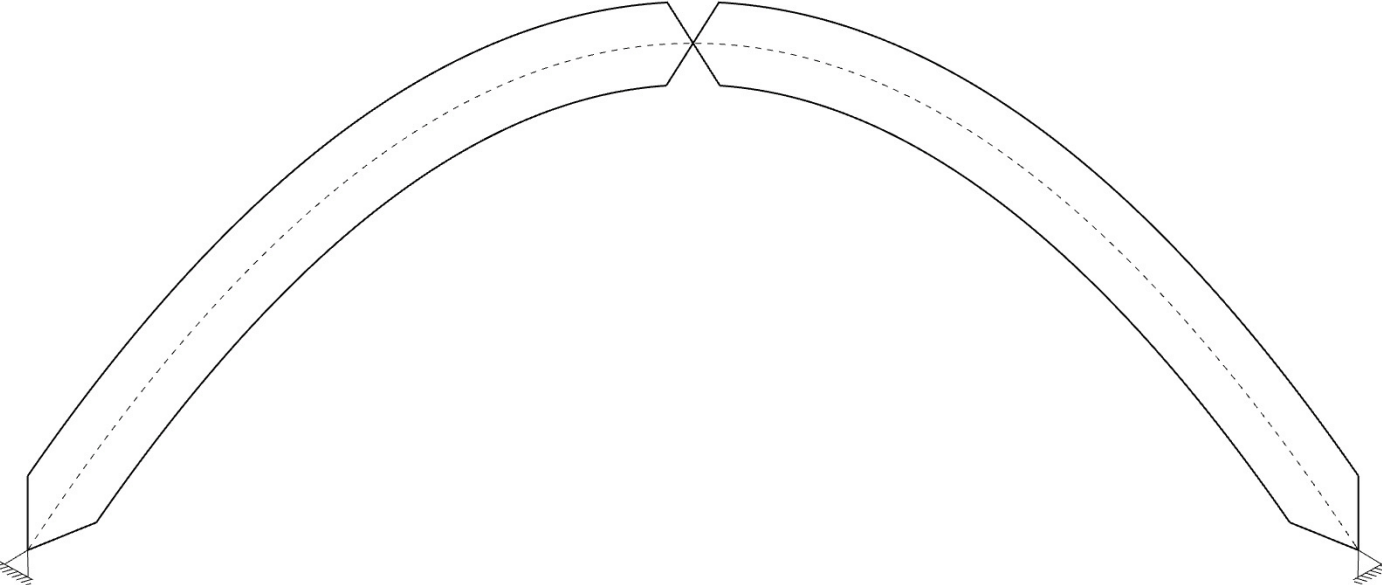

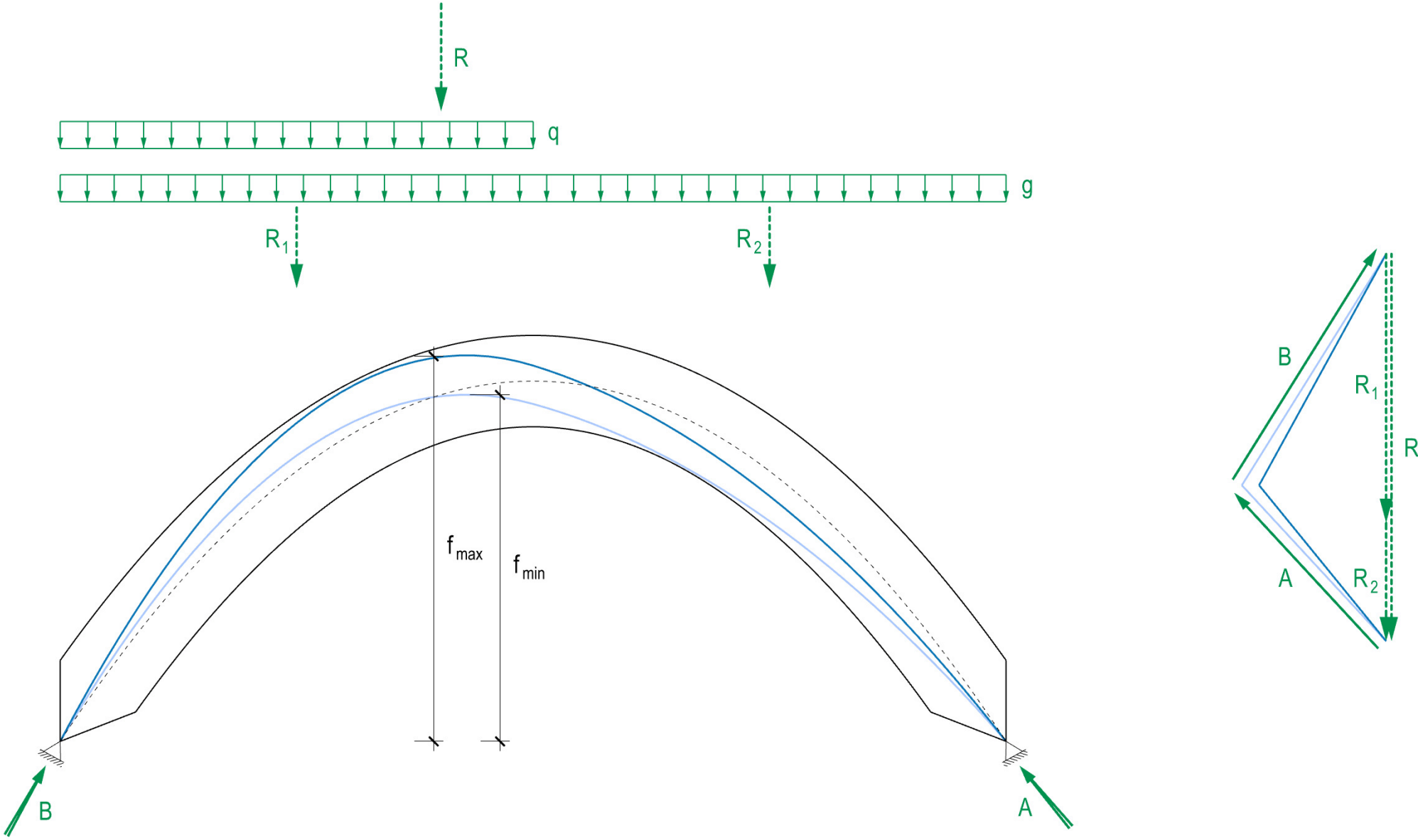



Robert Maillart: Salginatobel bridge, Schiers, 1930

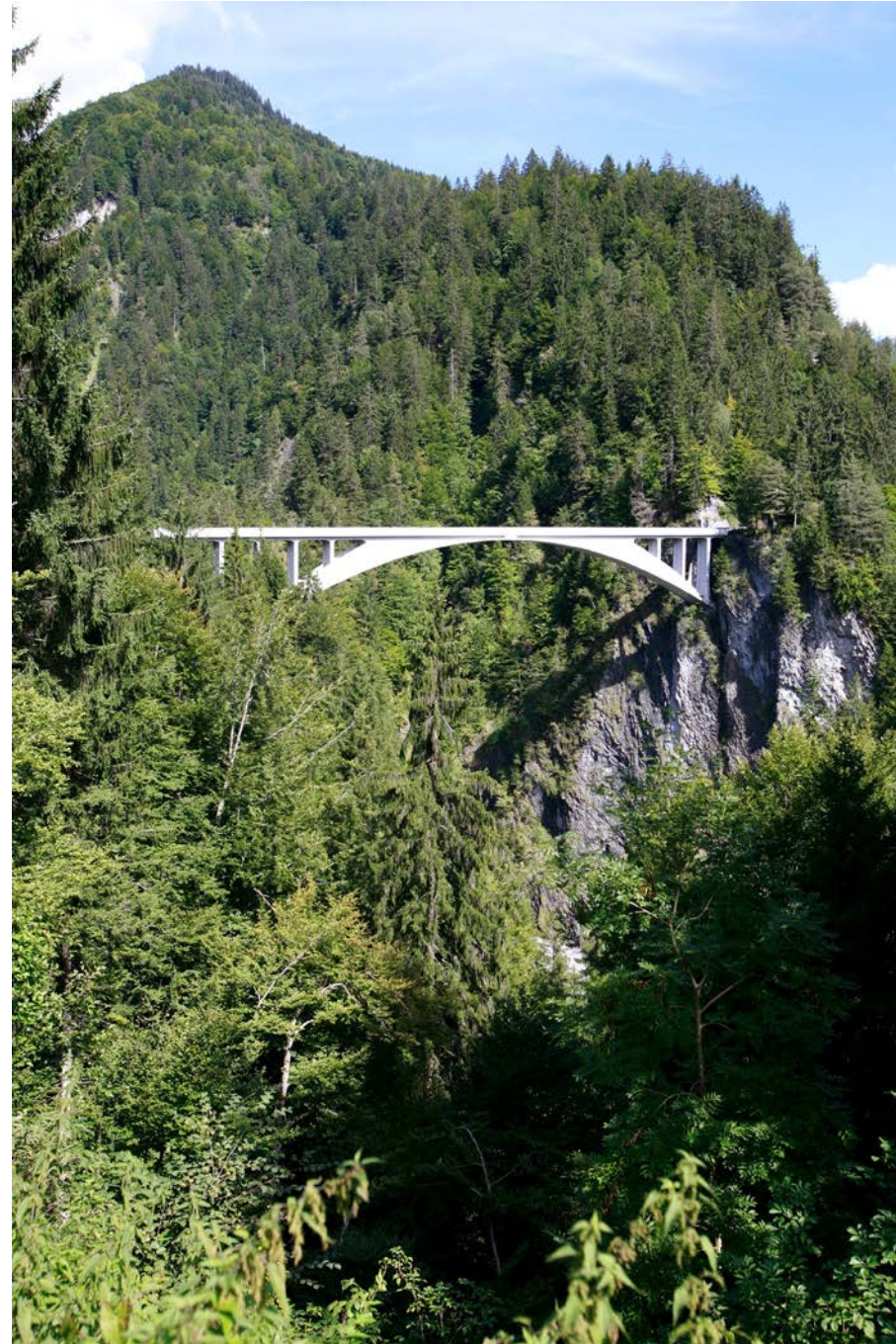

Robert Maillart: Salginatobel bridge, Schiers, 1930

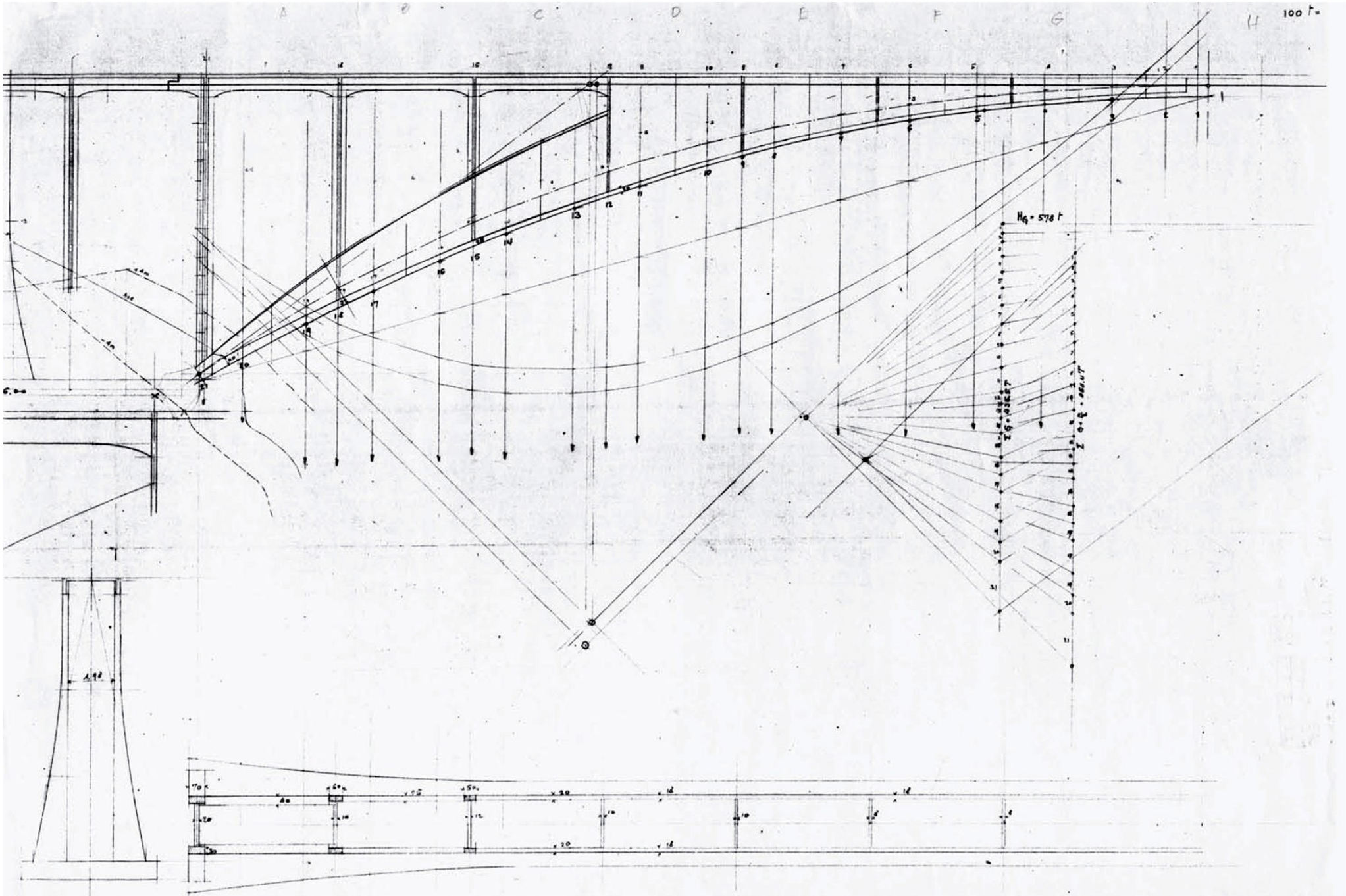

Robert Maillart: Salginatobel bridge, Schiers, 1930

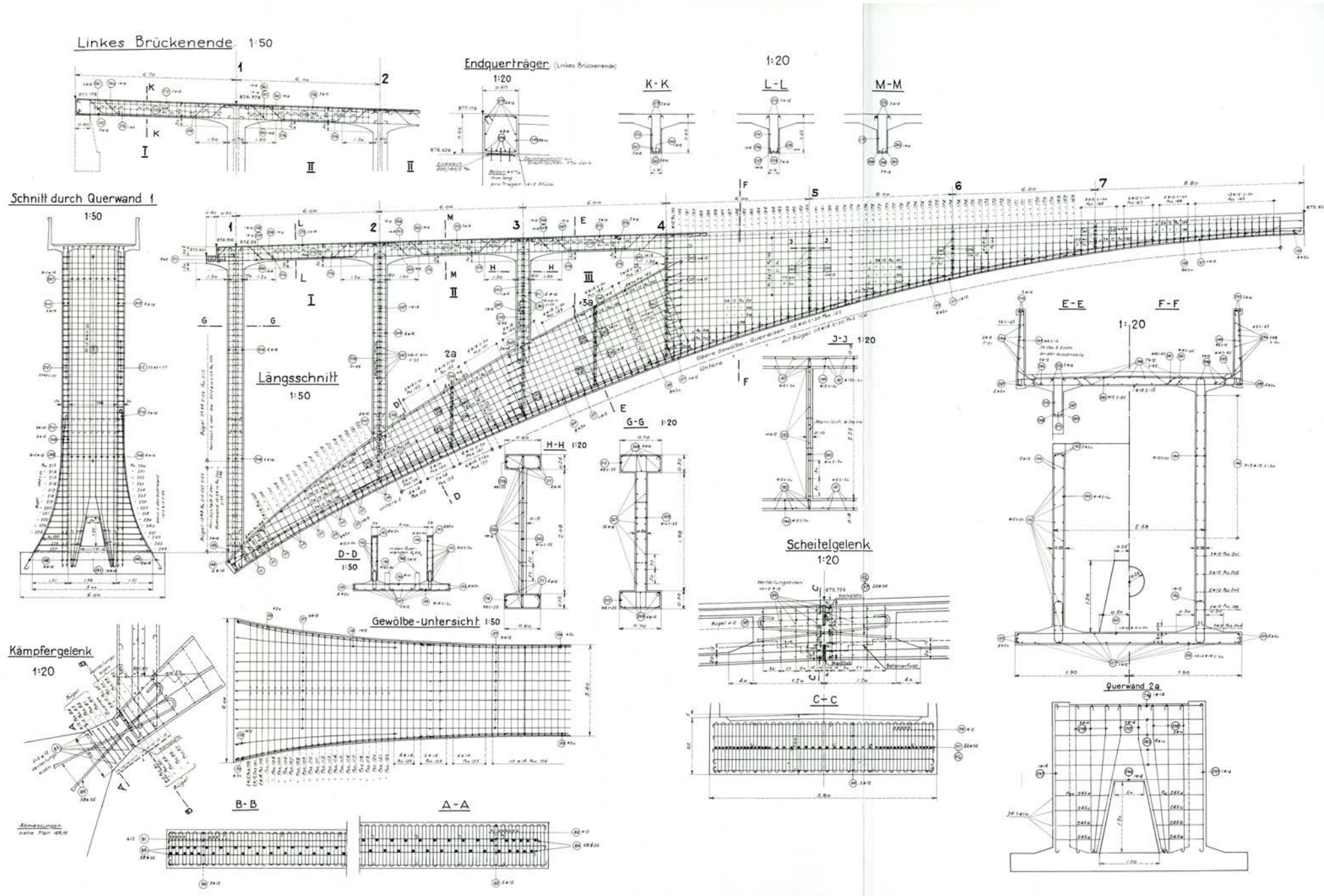

Robert Maillart: Salginatobel bridge, Schiers, 1930

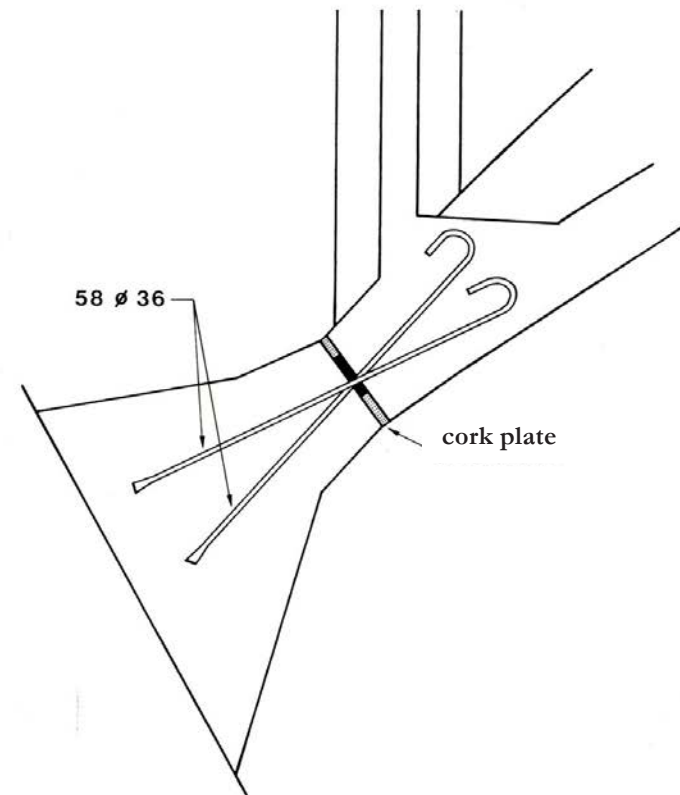
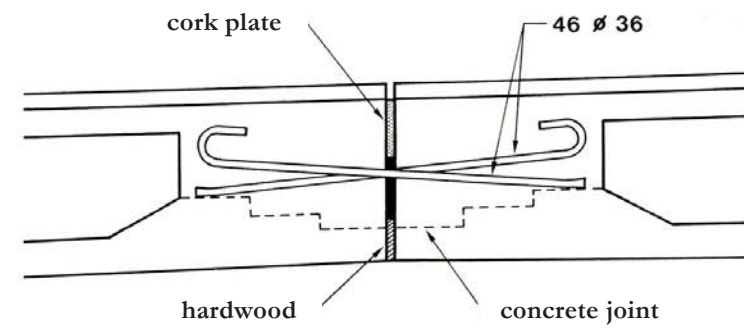

Robert Maillart: Salginatobel bridge, Schiers, 1930



Robert Maillart: Salginatobel bridge, Schiers, 1930



Robert Maillart: Salginatobel bridge, Schiers, 1930



Robert Maillart: Salginatobel bridge, Schiers, 1930

eQ: Salginatobel Bridge

Form Diagram

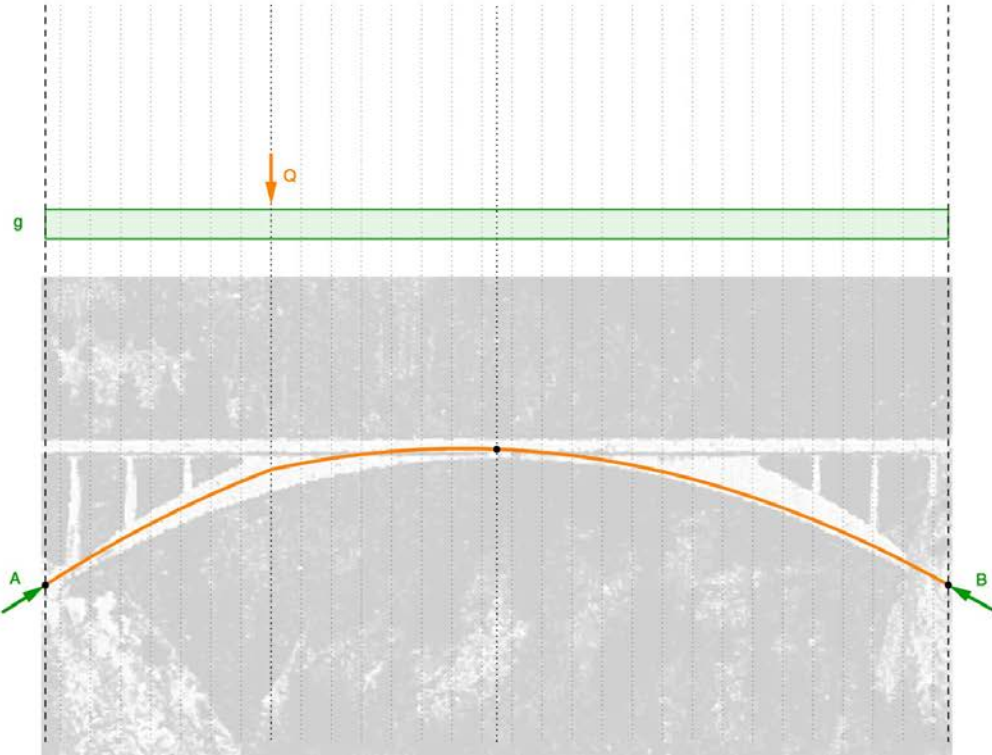

Force Diagram

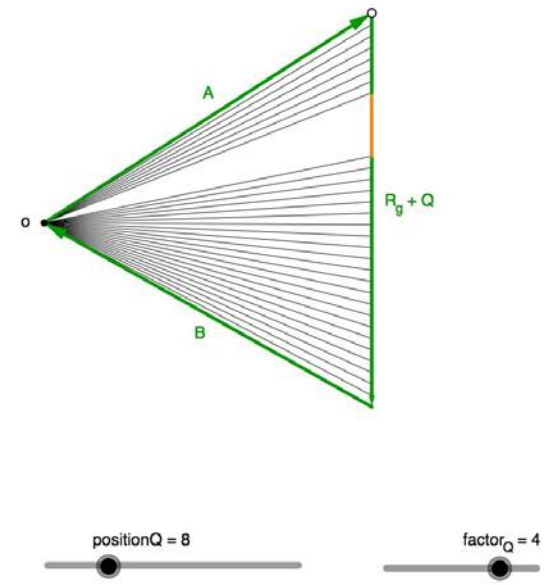

<http://www.block.arch.ethz.ch/eq/drawing/view/18>



Sir Horace Jones and Sir John Wolfe Barry: Tower Bridge, London, 1894

Gewölbe und Kuppeln

Vaults and domes

>> Gewölbe
Vaults

Kuppeln
Domes

Vaults

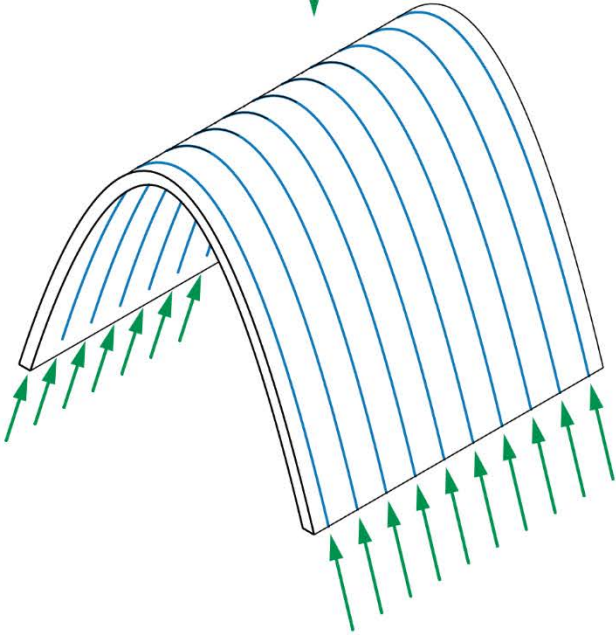
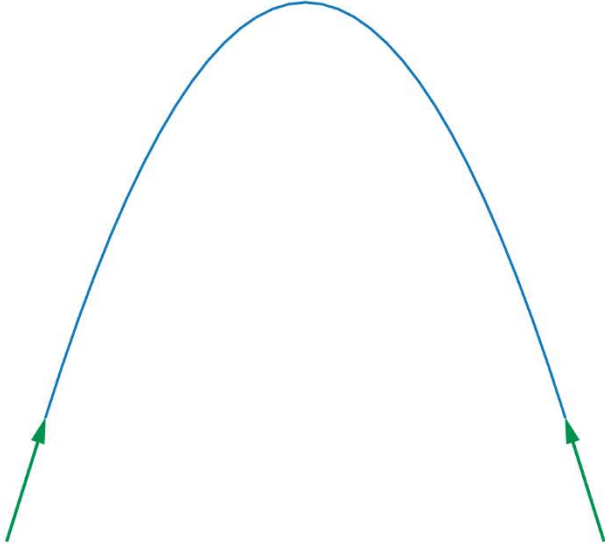
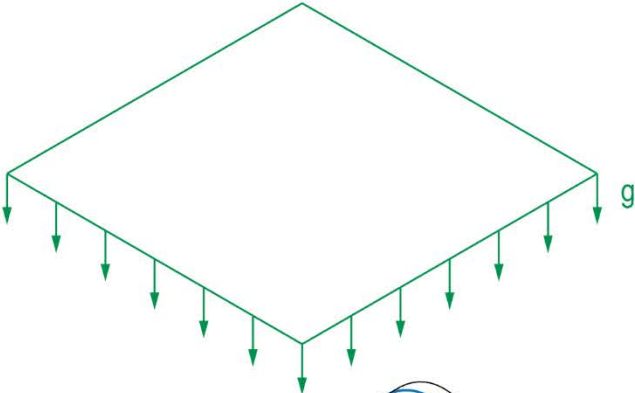
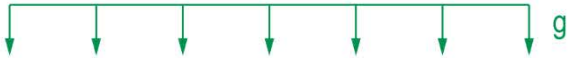

Tonnengewölbe

Barrel vault



Vault to cover the courtroom in the palace of Ctesiphonte (Bagdad), III-VI-century A.D.



Boston Public Library

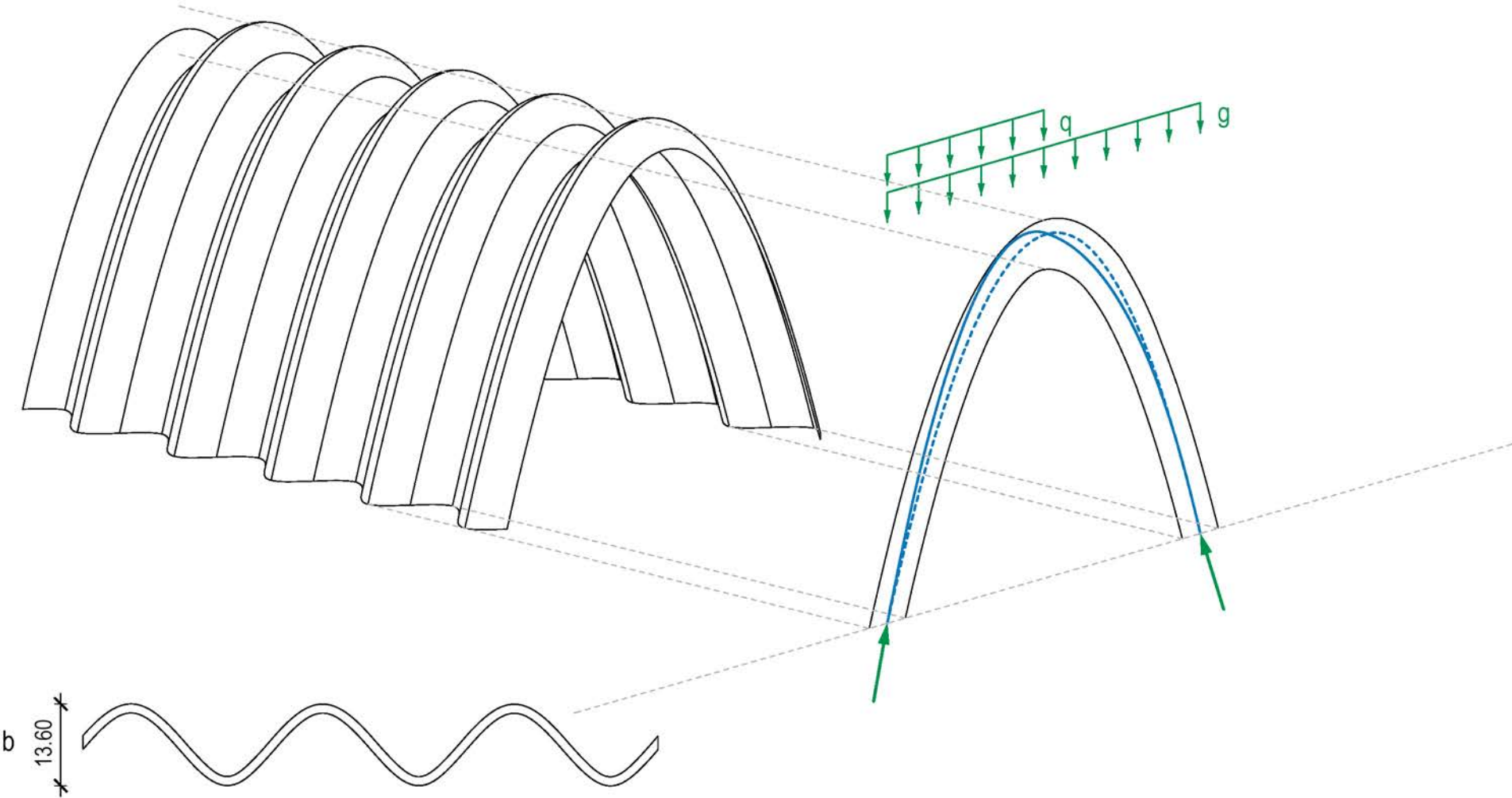



Eladio Dieste: Caryl Horizontal Silo, Young, Uruguay, 1978

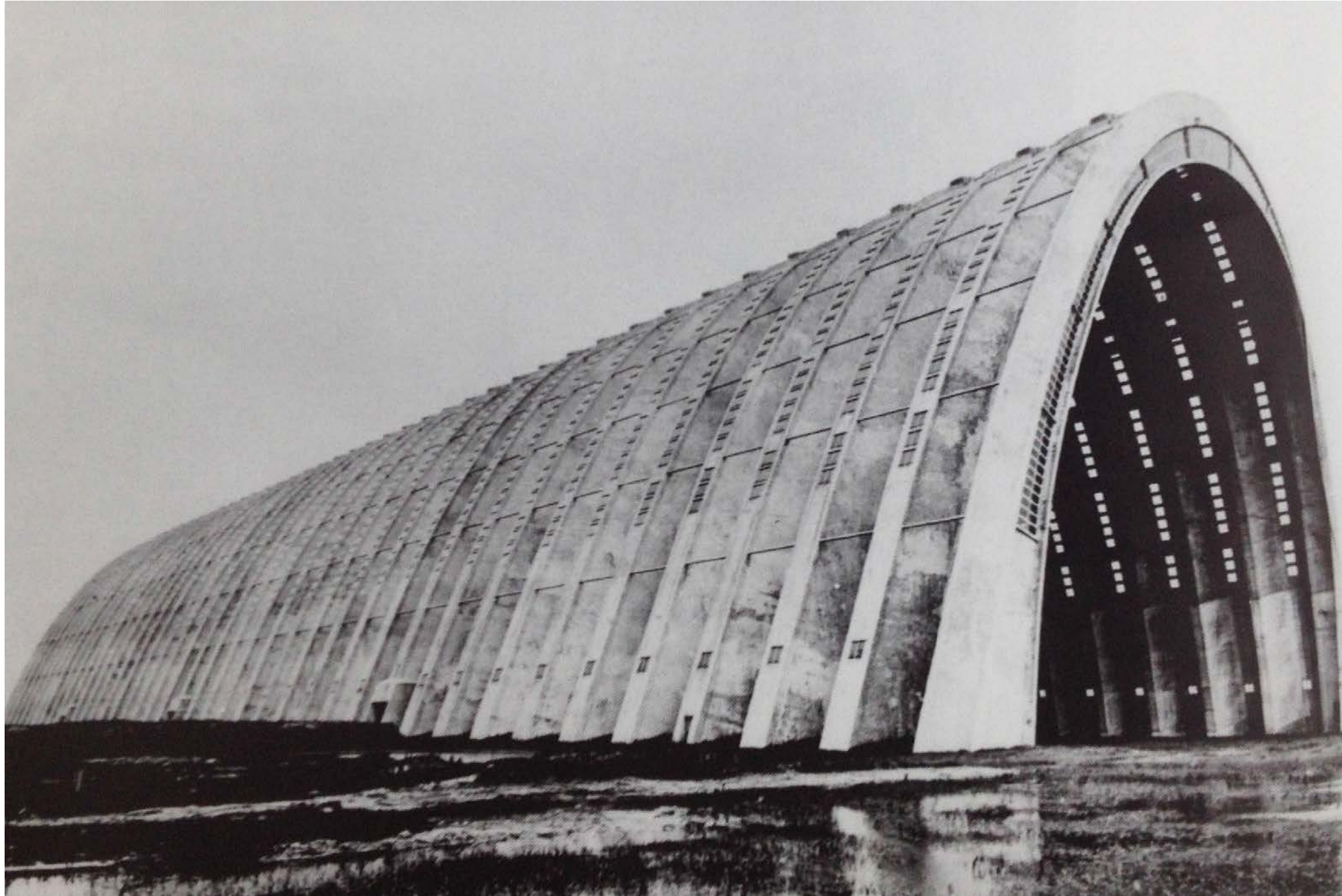

Eugène Freyssinet: Hangar d'Orly, Orly, France, 1923



Pier Luigi Nervi: Main hall Expo Turino, Italy, 1949

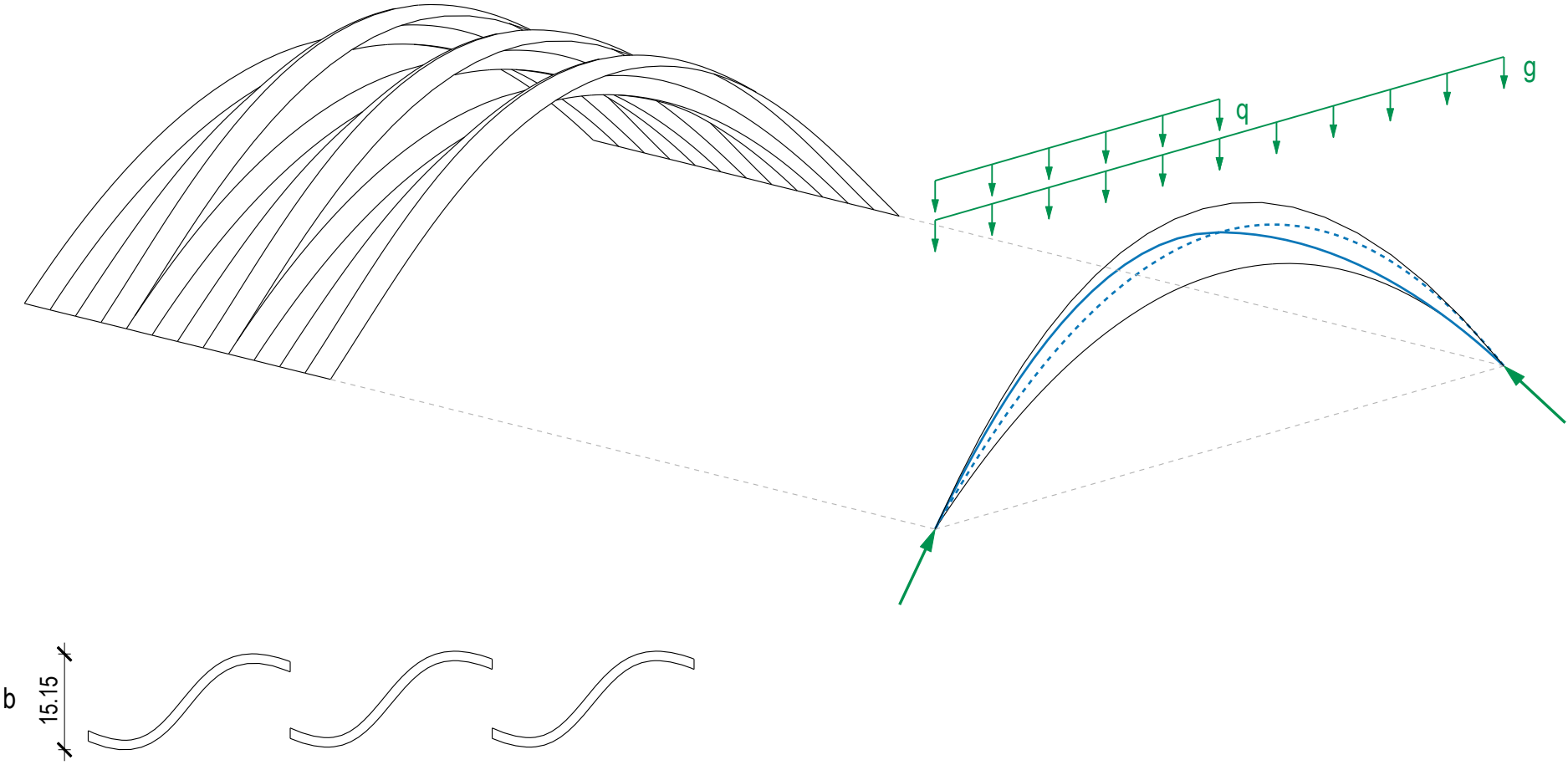



Eladio Dieste: Gimnasio de Durazno, Durazno, Uruguay, 1975

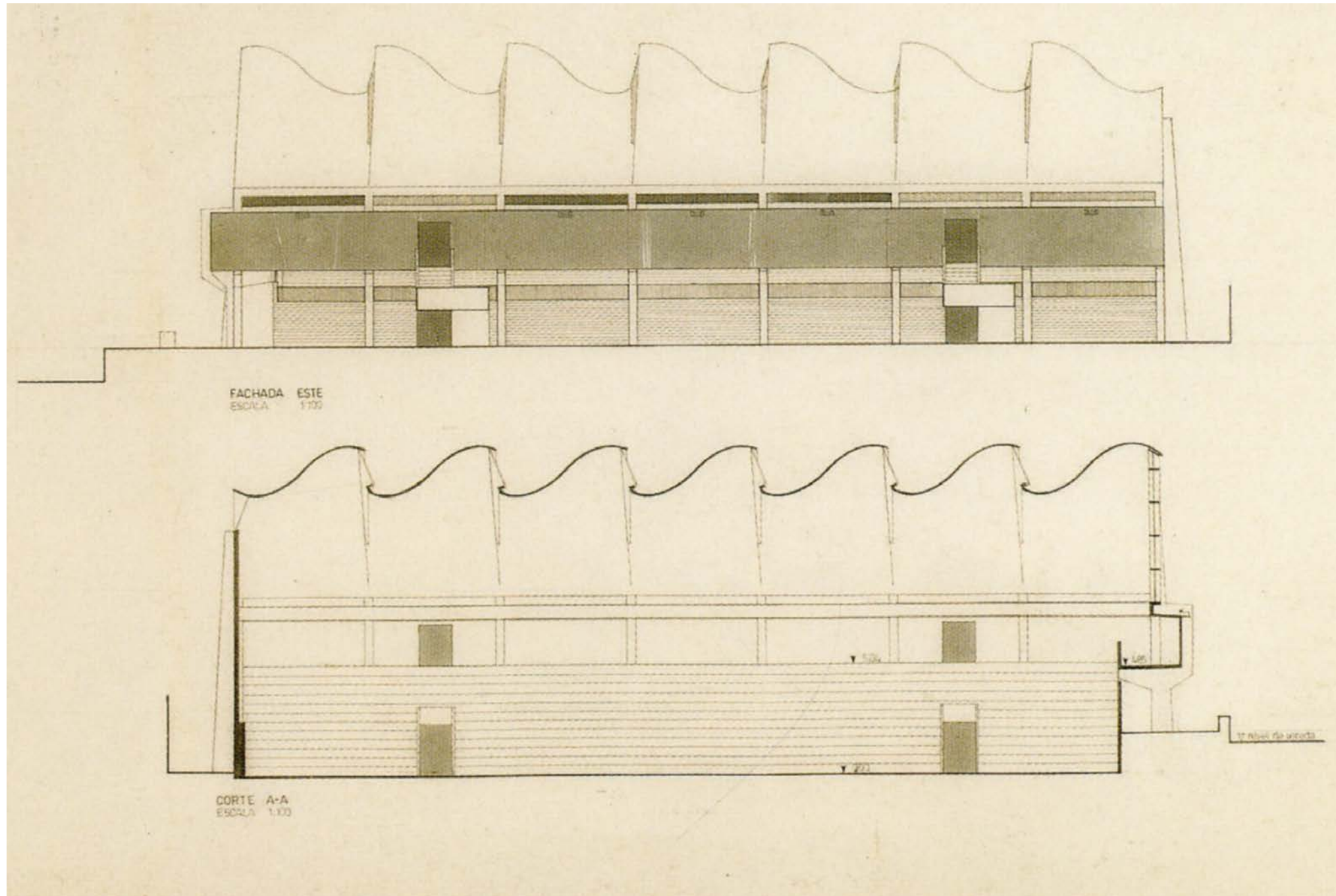

Eladio Dieste: Gimnasio de Durazno, Durazno, Uruguay, 1975

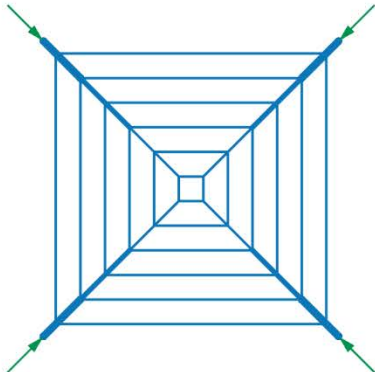
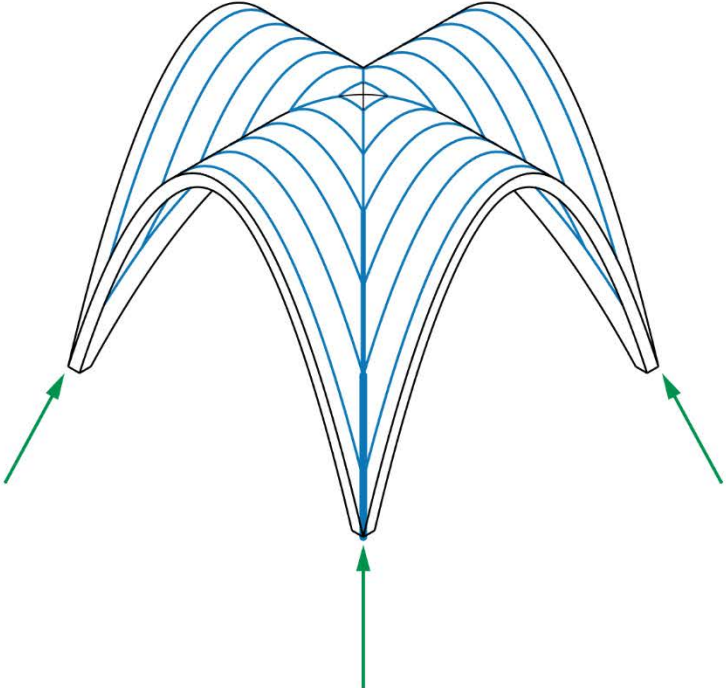
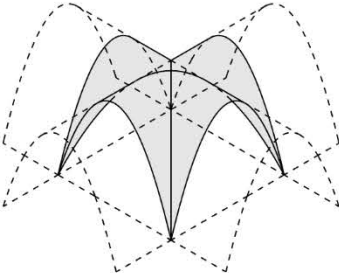
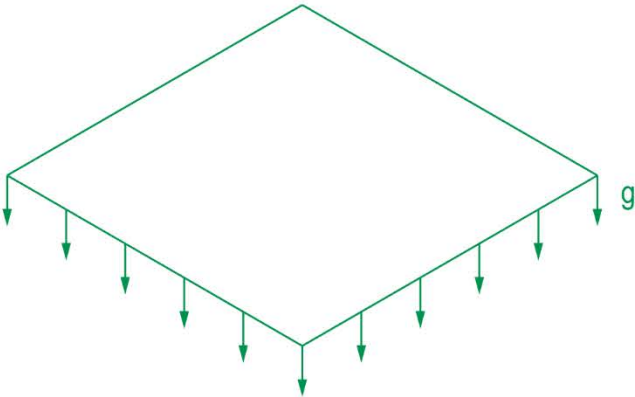

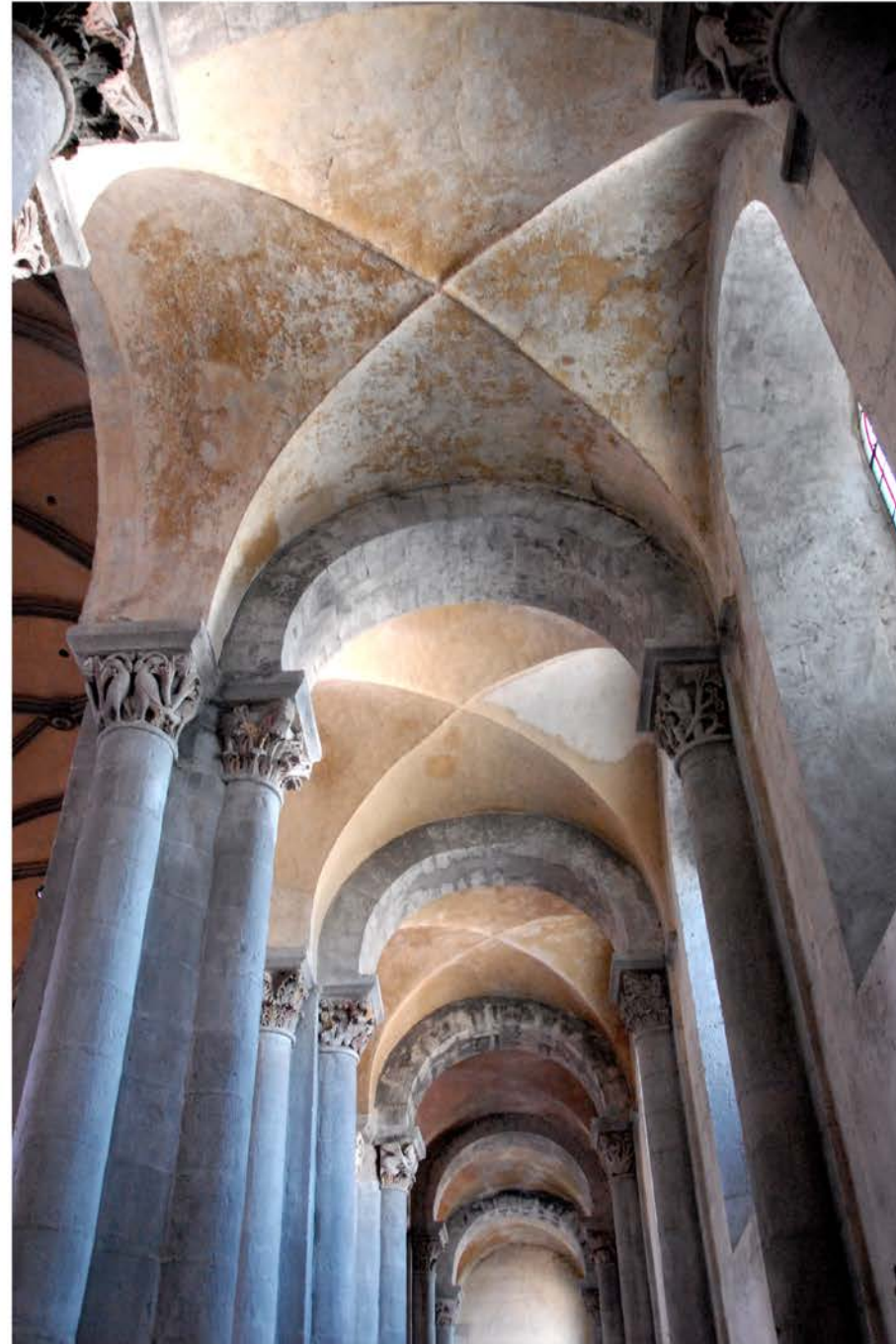

Vezelay Abbey, Burgundy, France, 11. century

Vaults

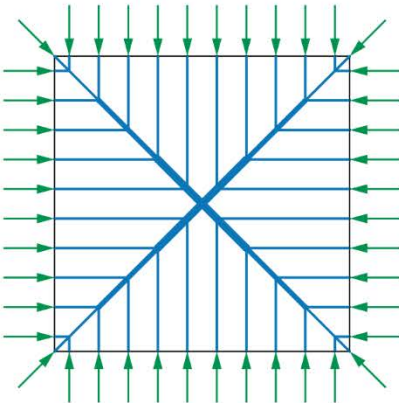
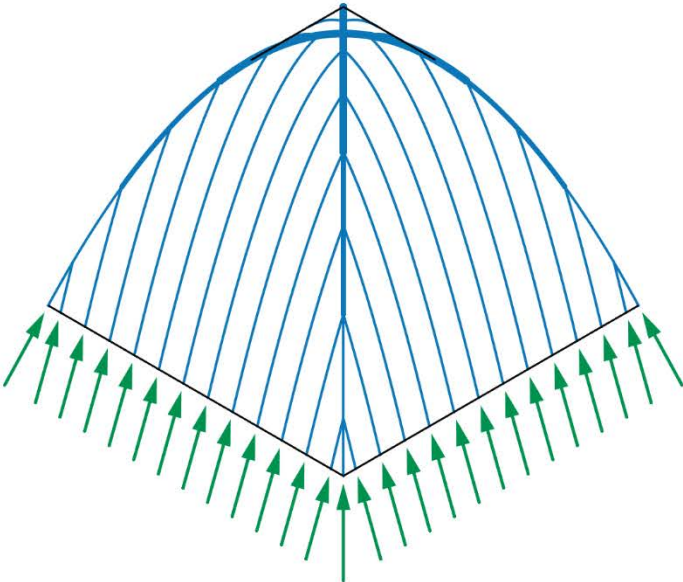
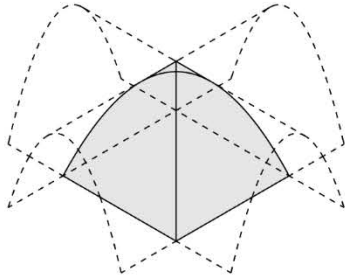
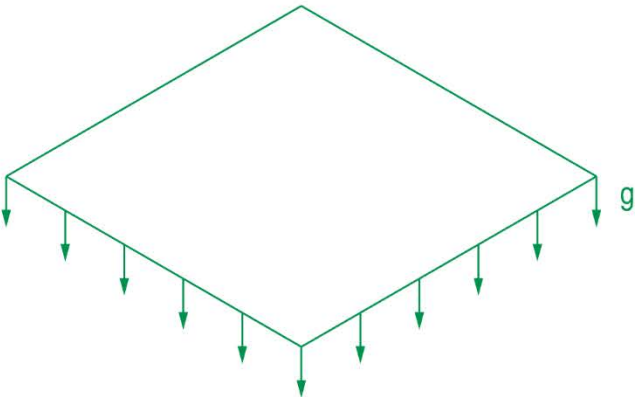

Pavillon vault



Pavilion vault with square plan, Otranto, Italy

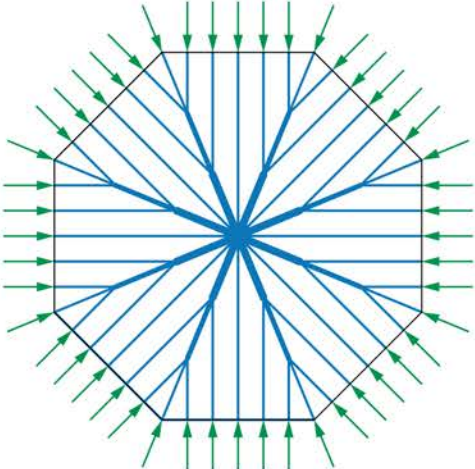
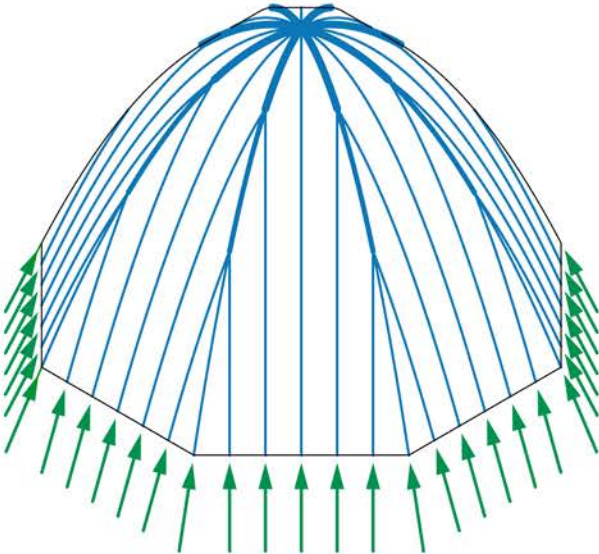
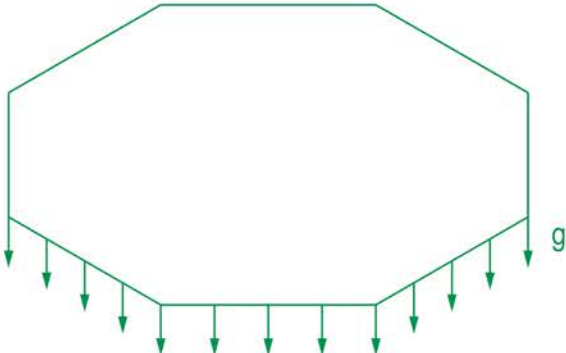



“Dome” of Santa Maria del Fiore, Arch. & Ing.: Filippo Brunelleschi, Florenz, 1418

Gewölbe und Kuppeln

Vaults and domes

Gewölbe

Vaults

>>

Kuppeln

Domes

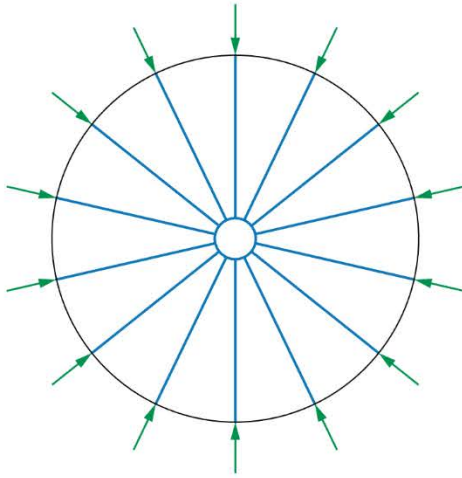
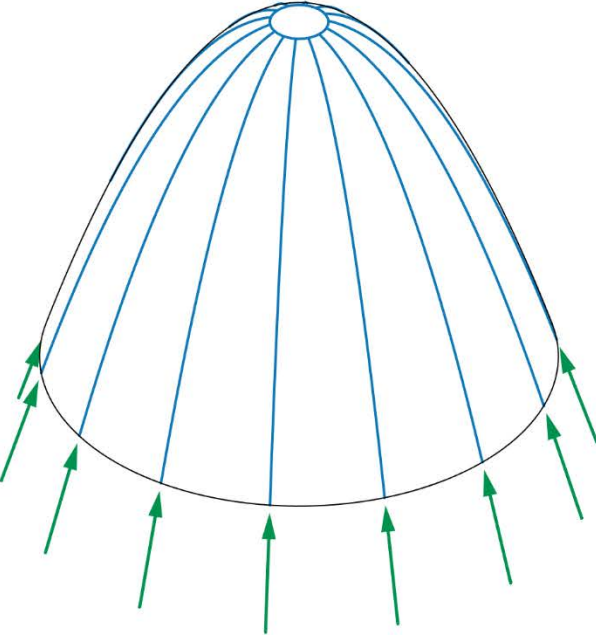
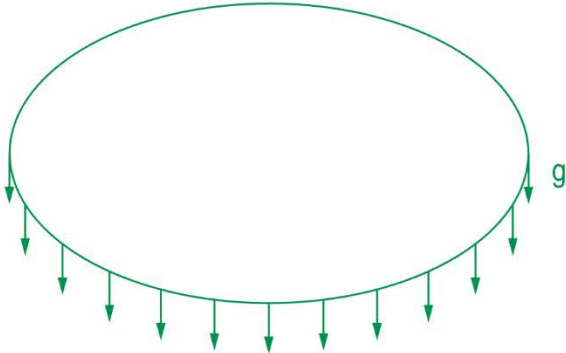

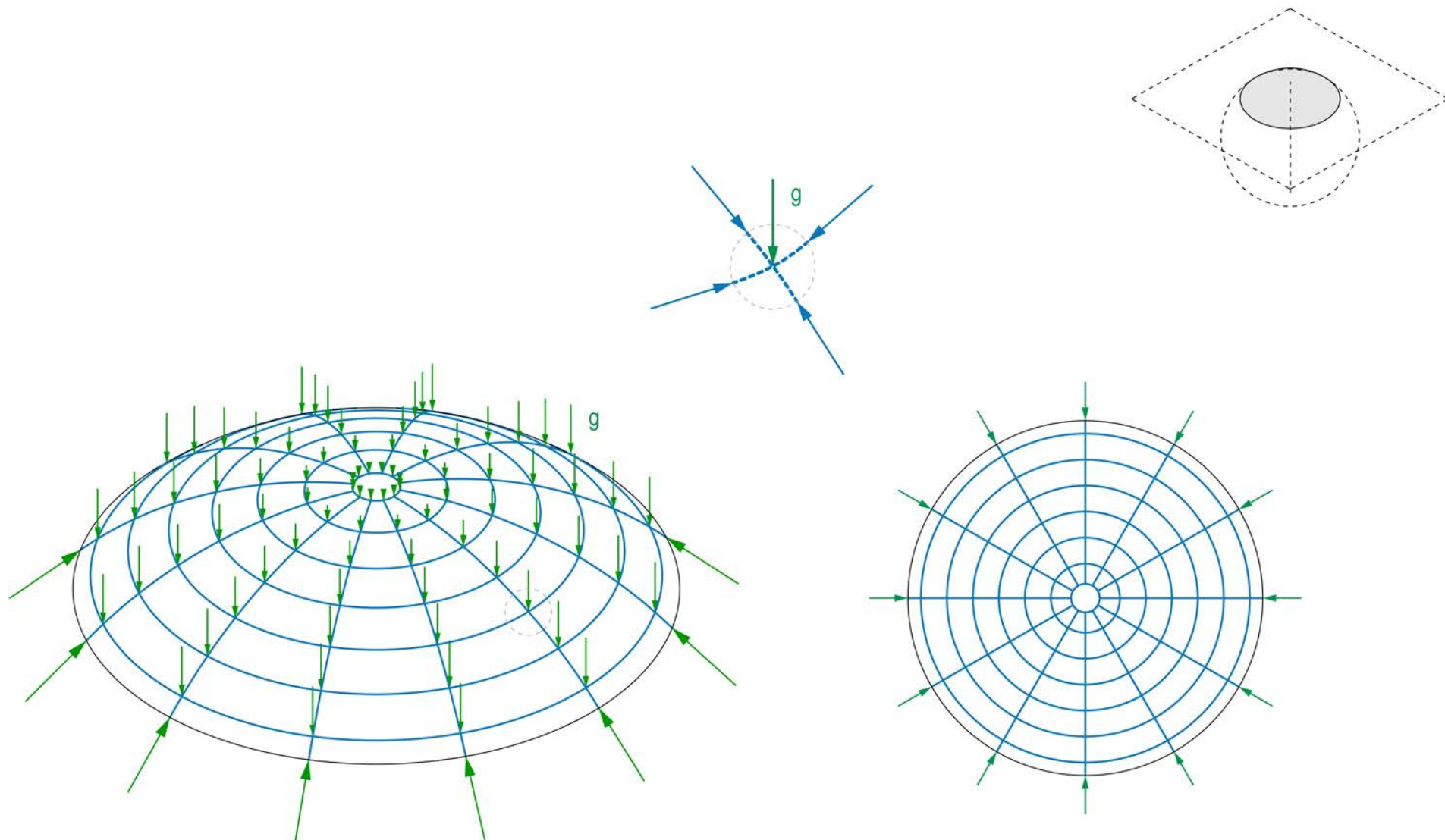

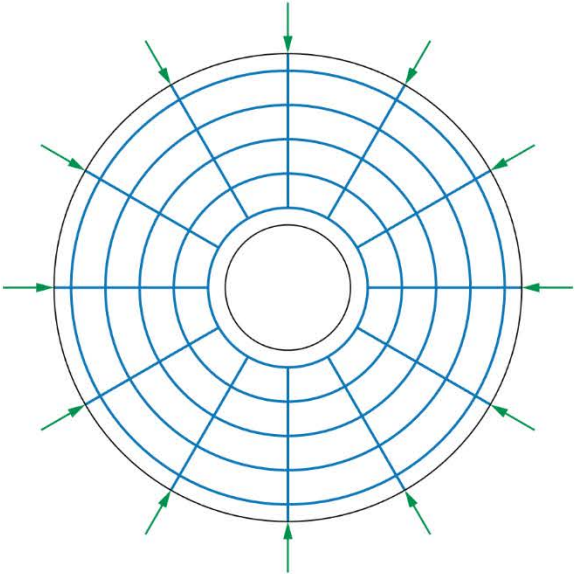
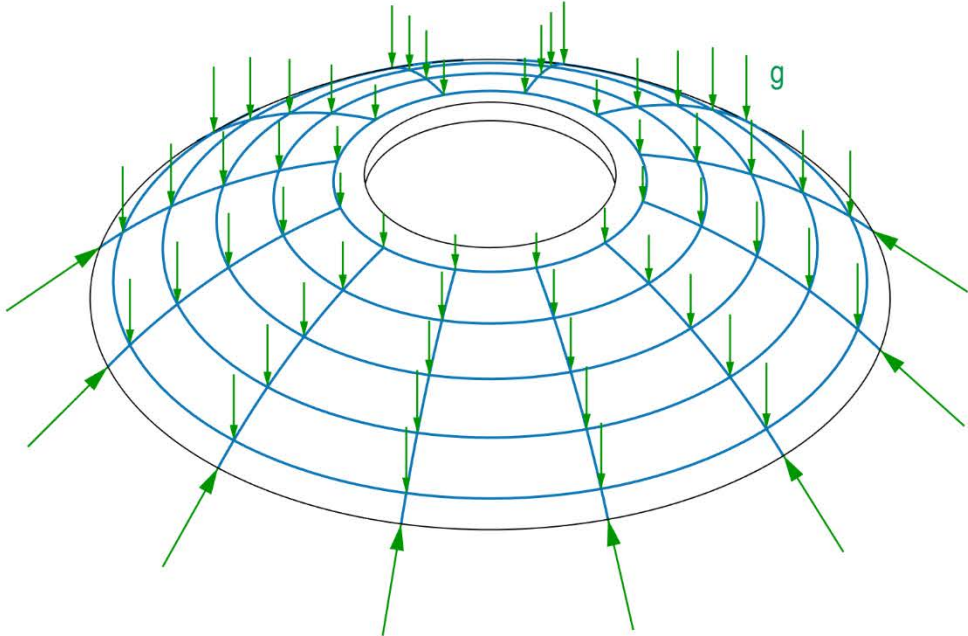



Palazzo dello Sport, Pier Luigi Nervi, Rome, Italy, 1955

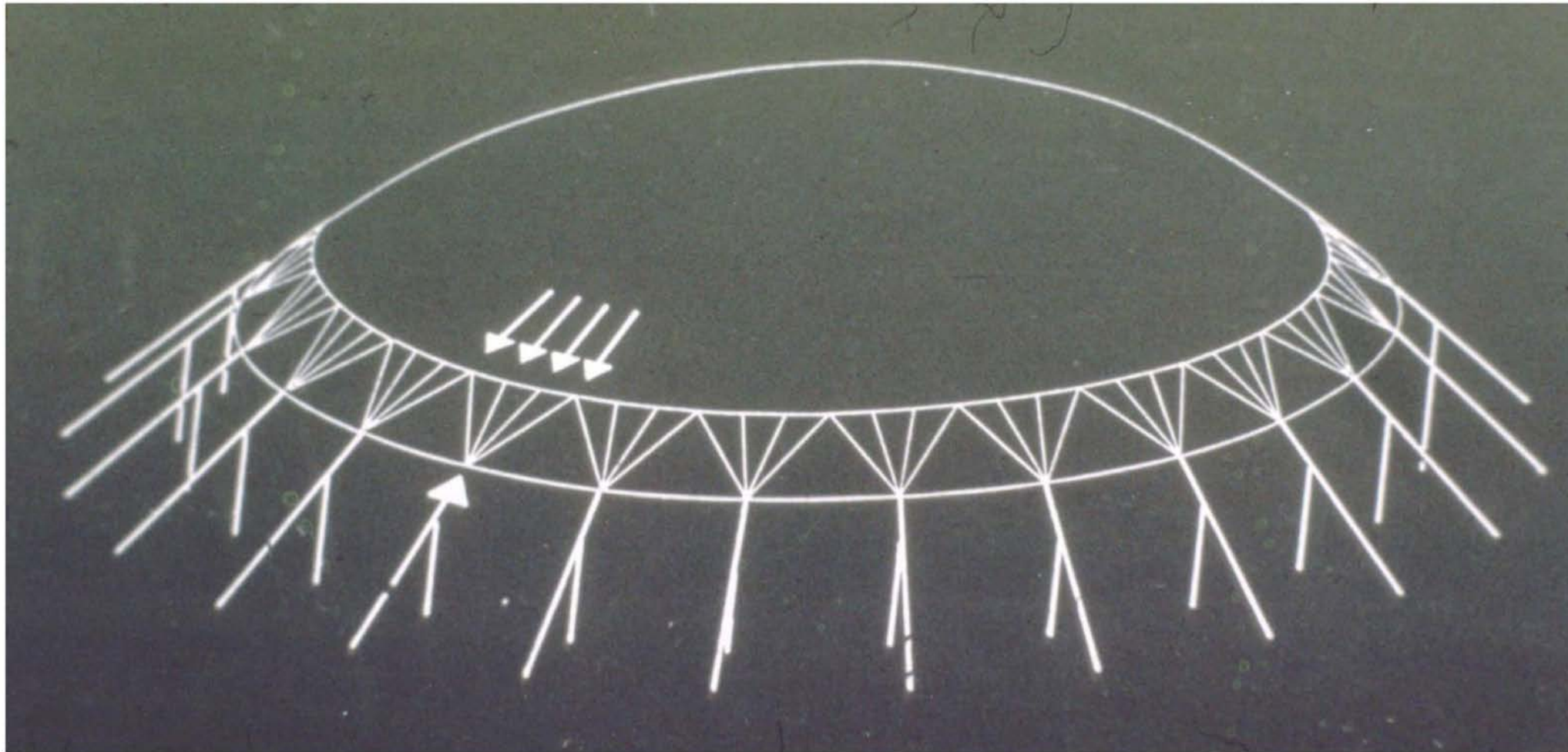

Palazzo dello Sport, Pier Luigi Nervi, Rome, Italy, 1955

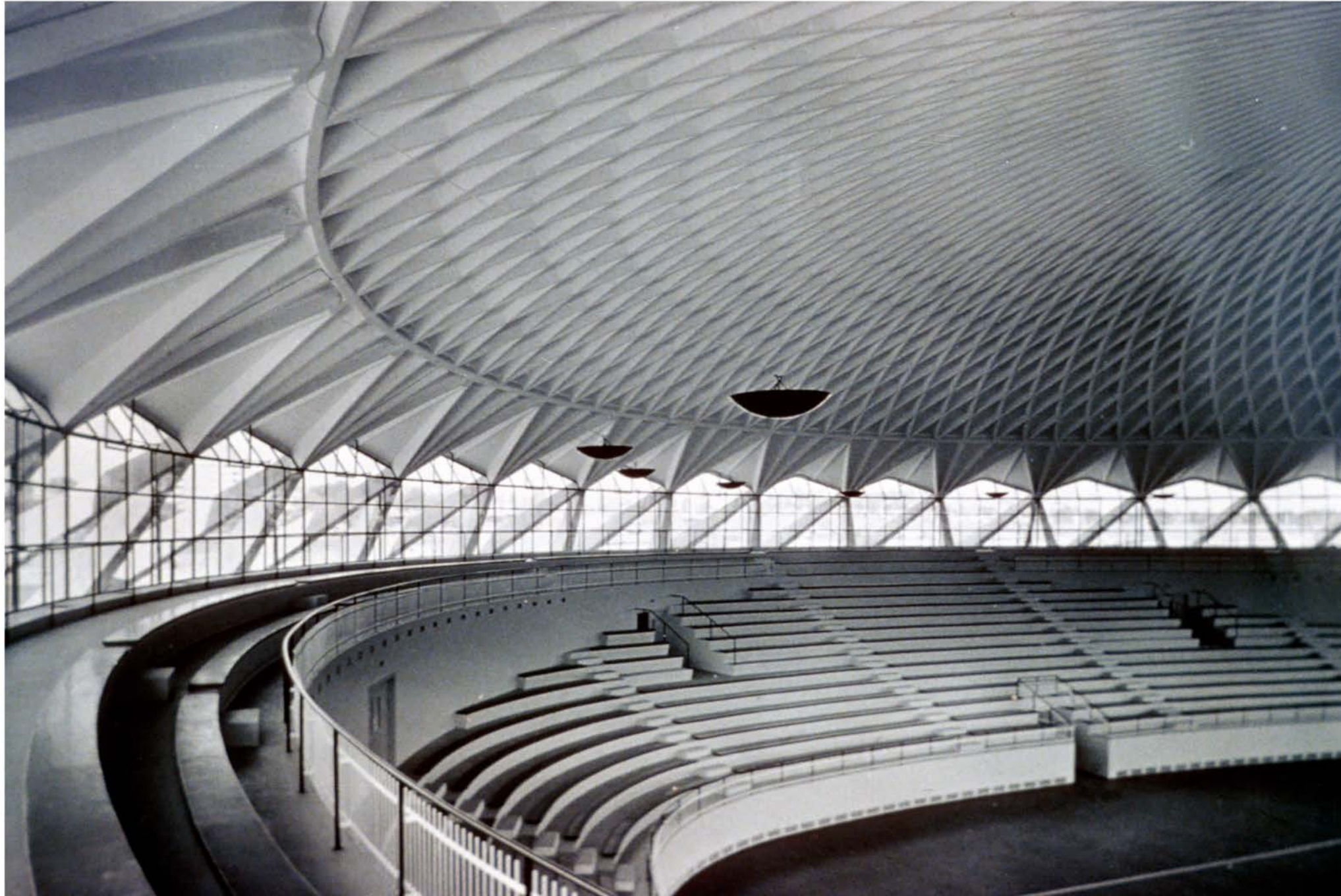

Palazzo dello Sport, Pier Luigi Nervi, Rome, Italy, 1955

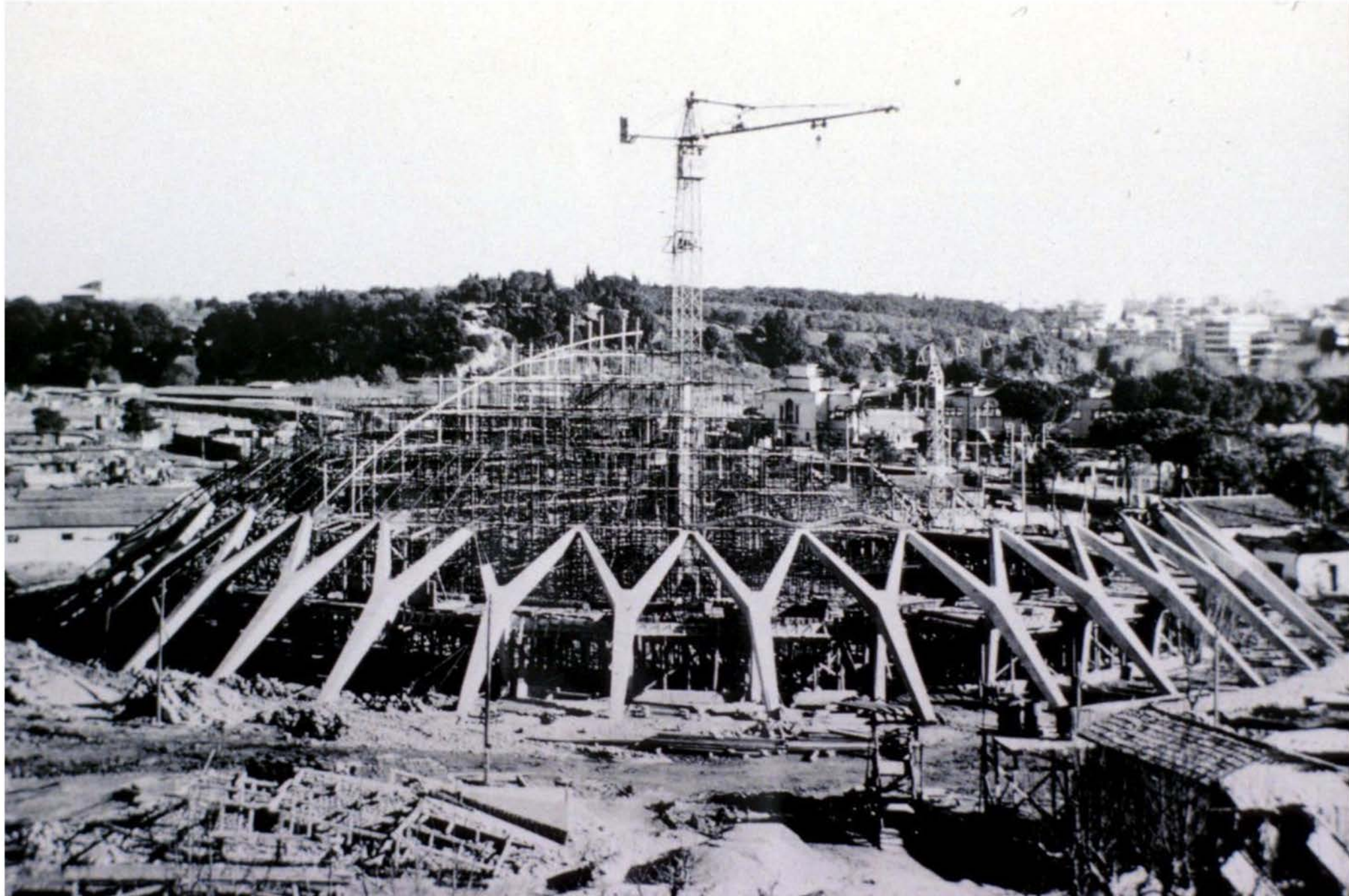

Palazzo dello Sport, Pier Luigi Nervi, Rome, Italy, 1955

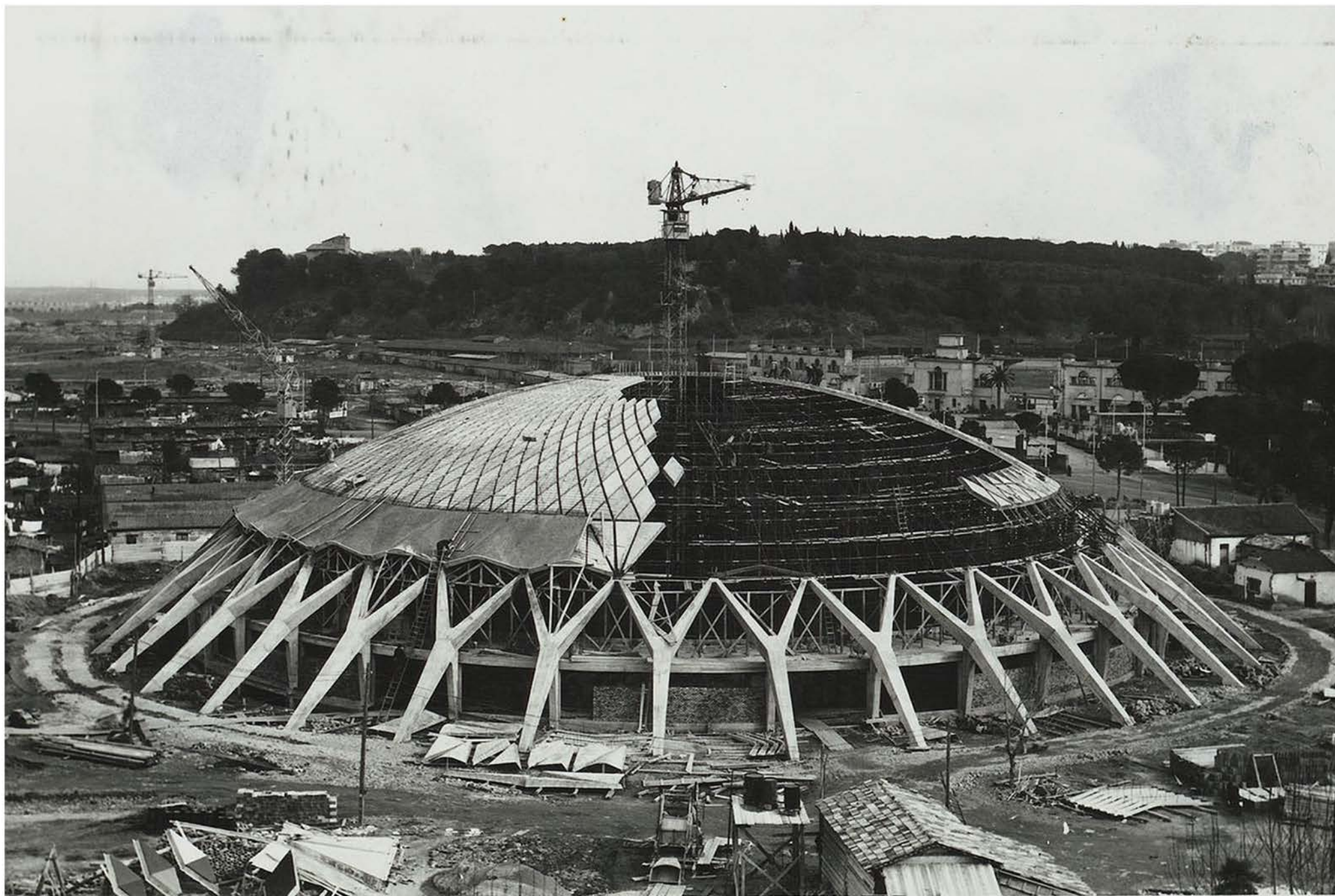

Palazzo dello Sport, Pier Luigi Nervi, Rome, Italy, 1955

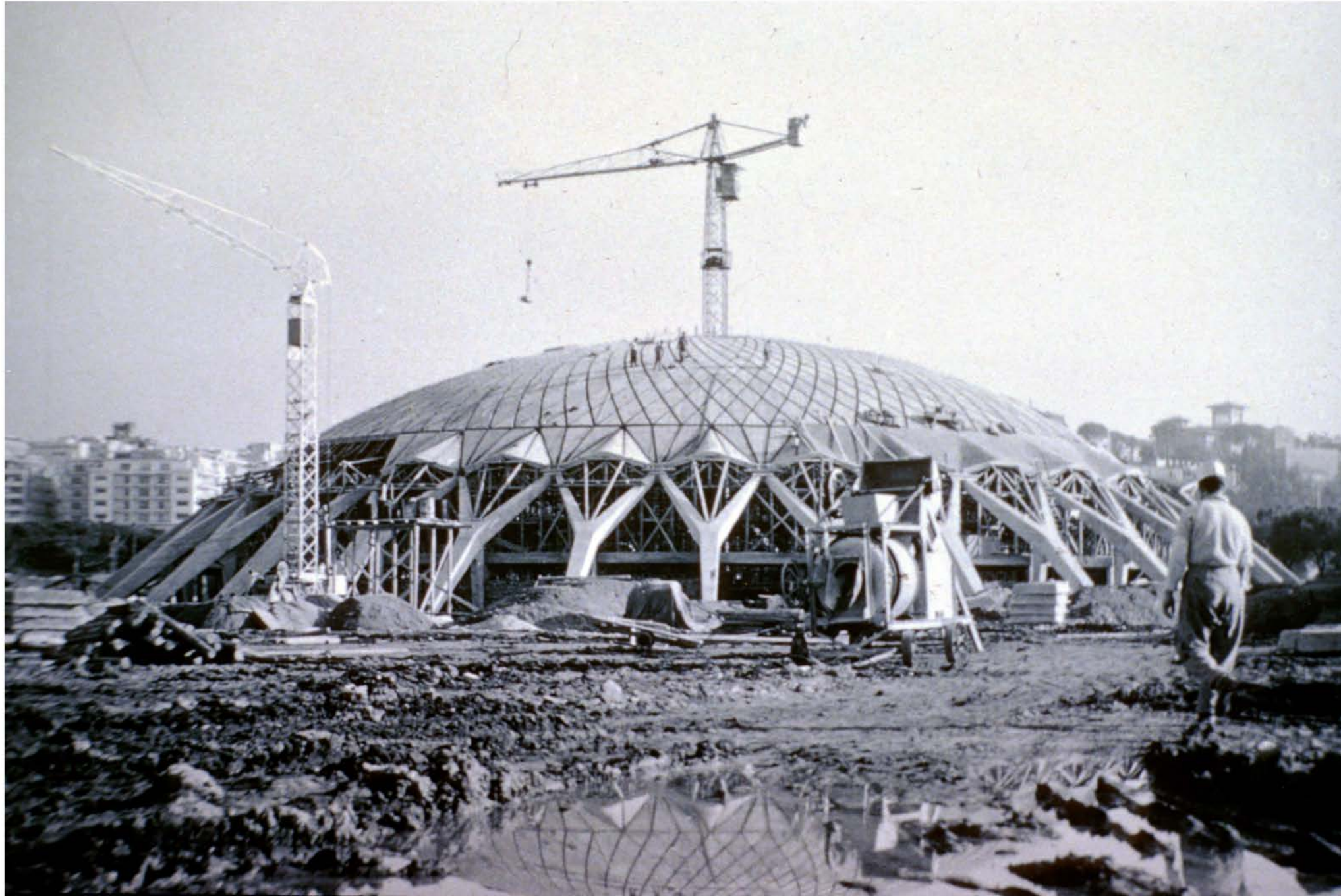

Palazzo dello Sport, Pier Luigi Nervi, Rome, Italy, 1955



Palazzo dello Sport, Pier Luigi Nervi, Rome, Italy, 1955



Palazzo dello Sport, Pier Luigi Nervi, Rome, Italy, 1955



Palazzo dello Sport, Pier Luigi Nervi, Rome, Italy, 1955

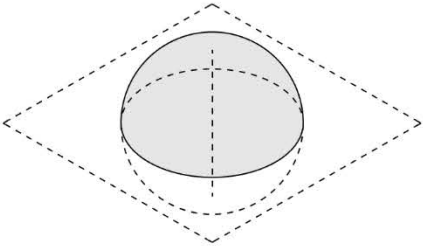
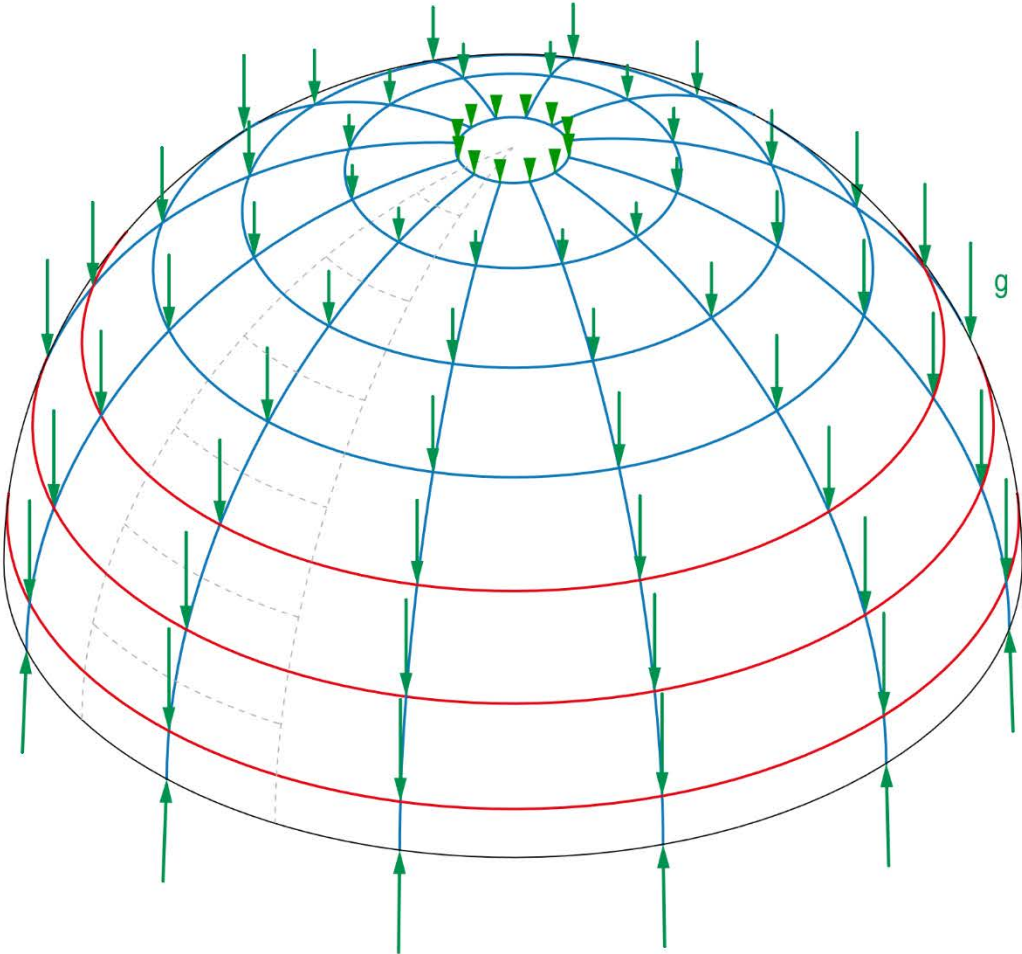

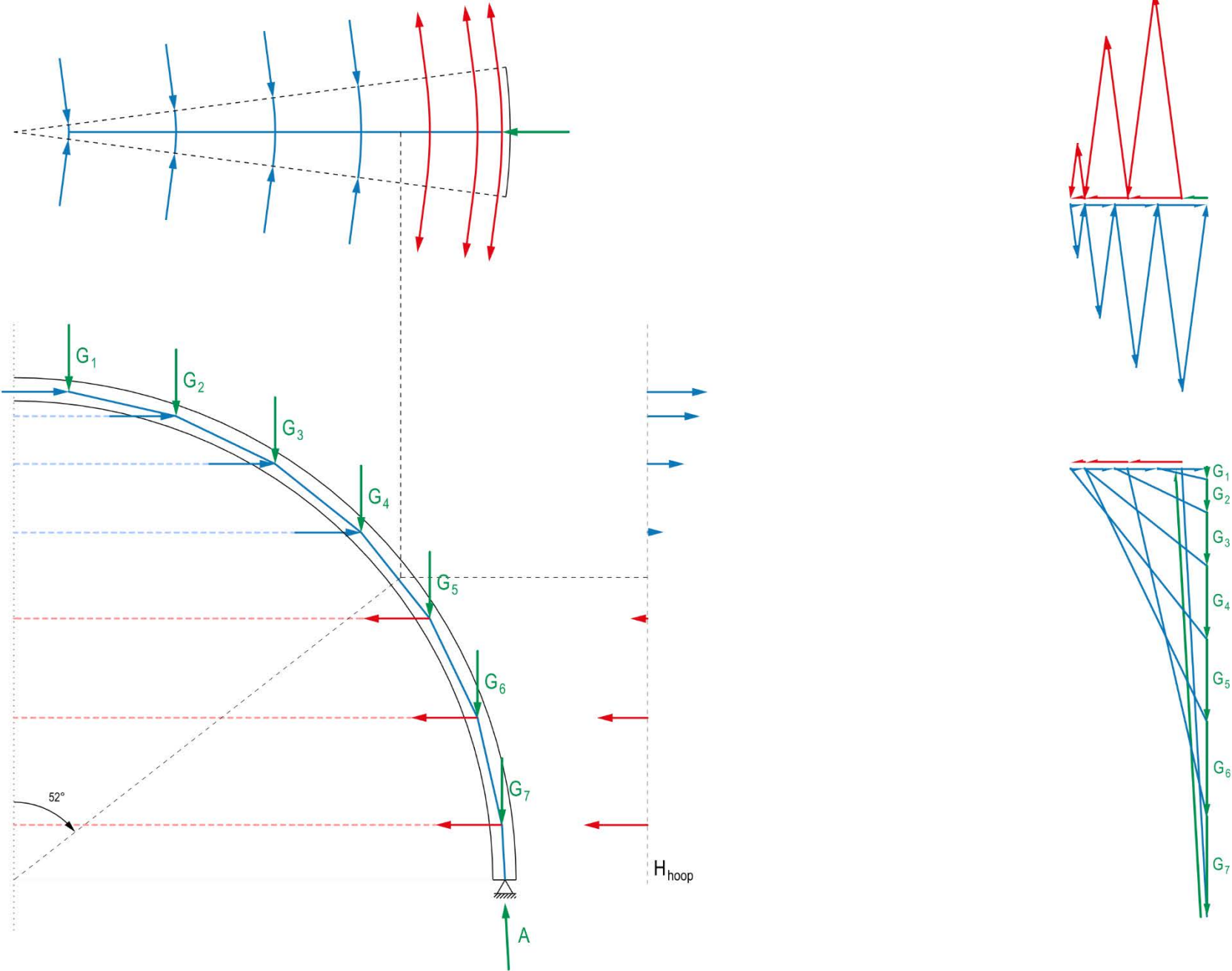



St.-Peter's Cathedral, Rome

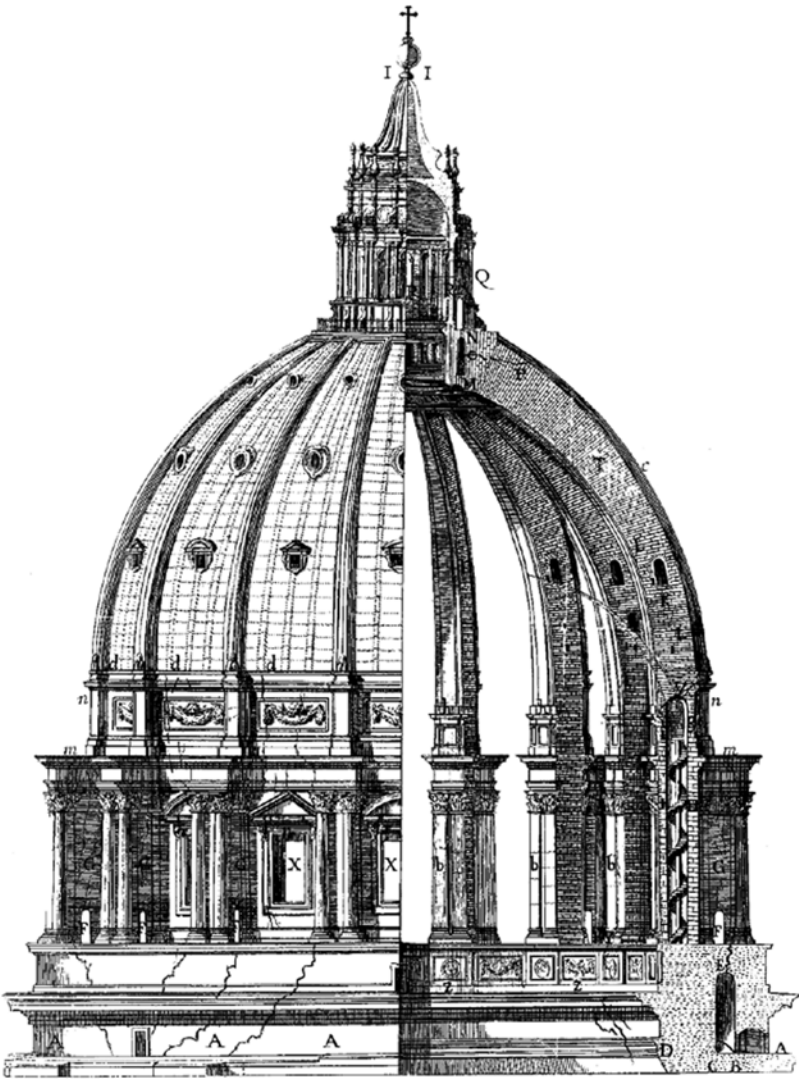
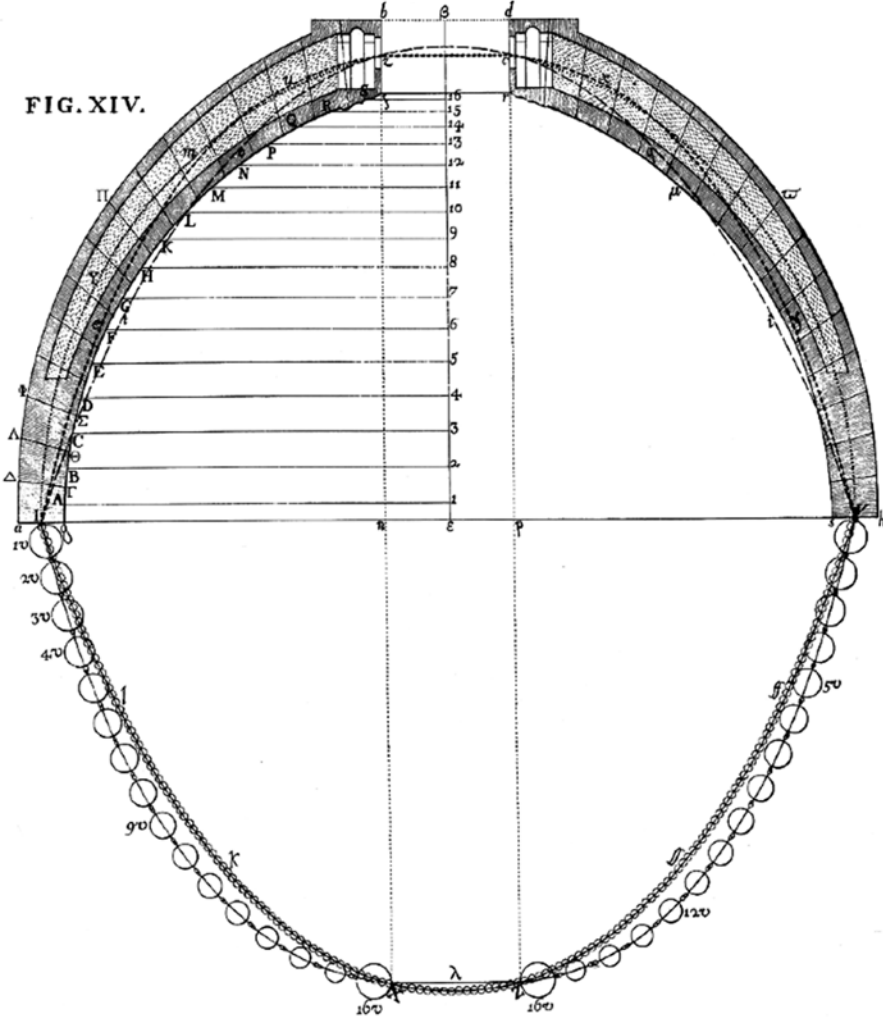
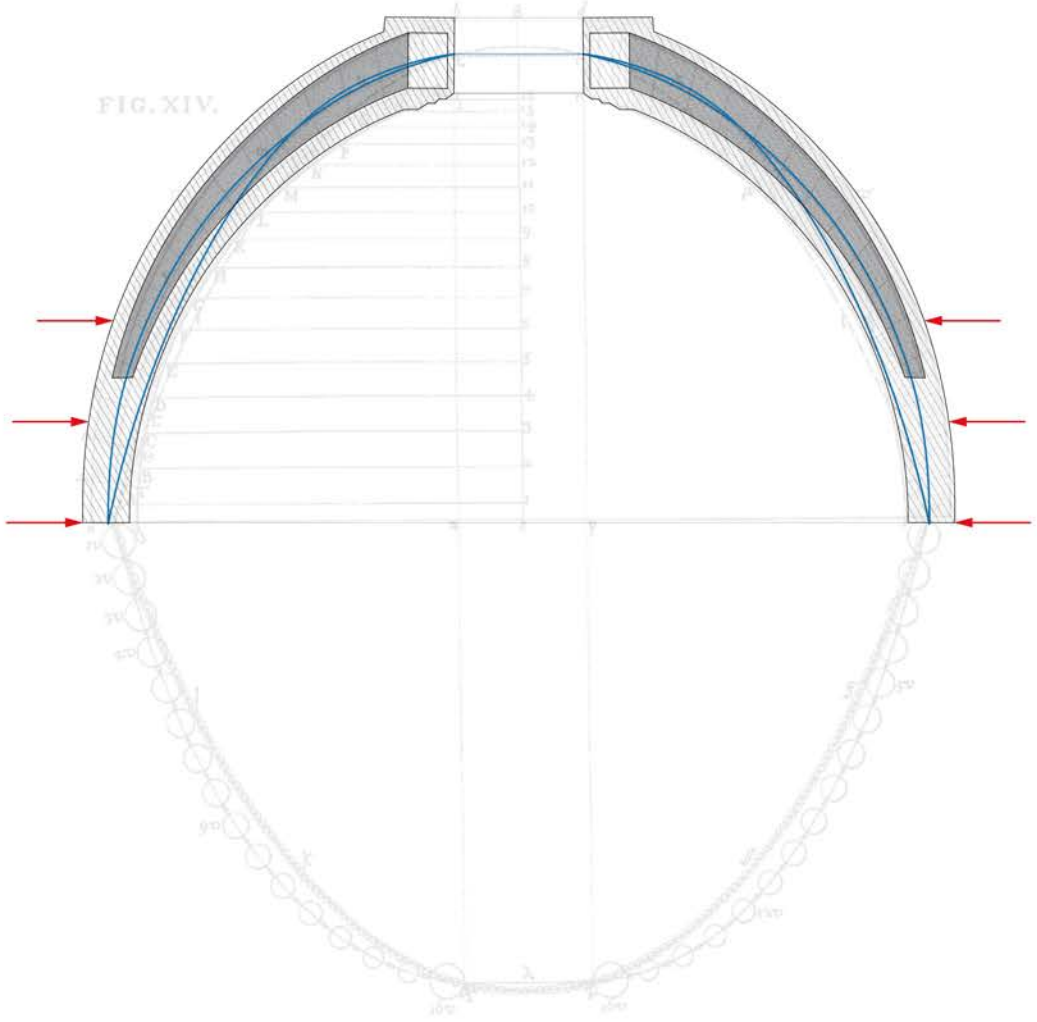
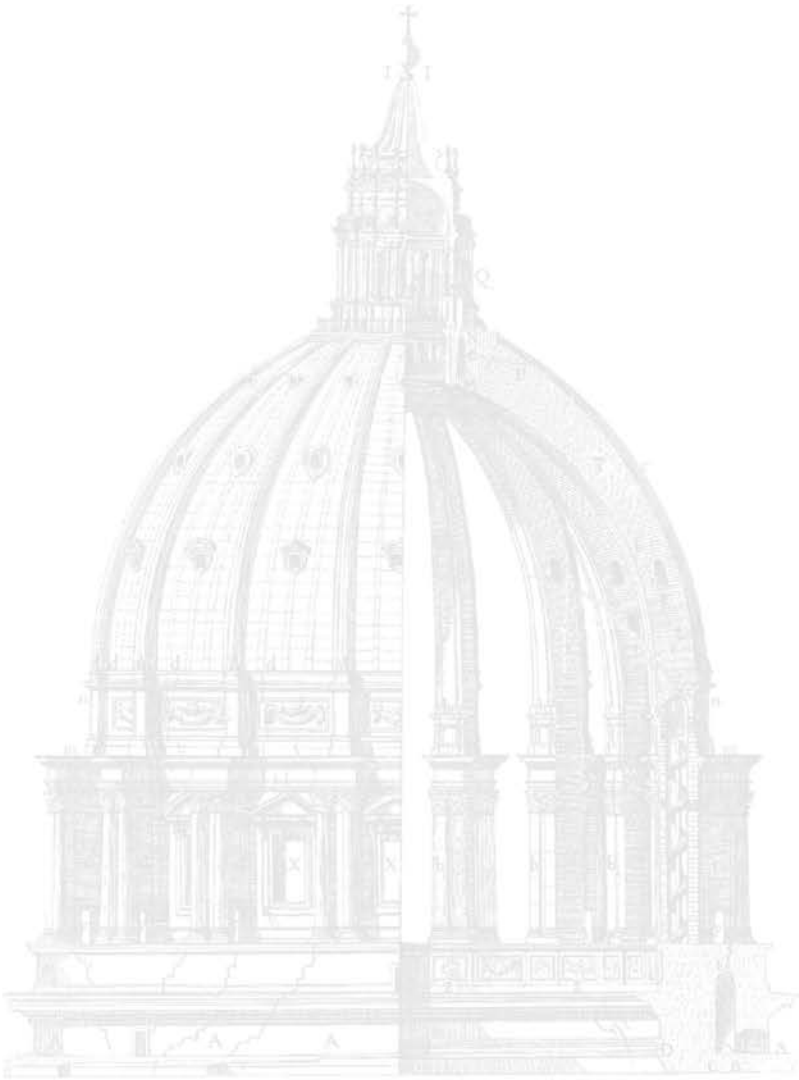
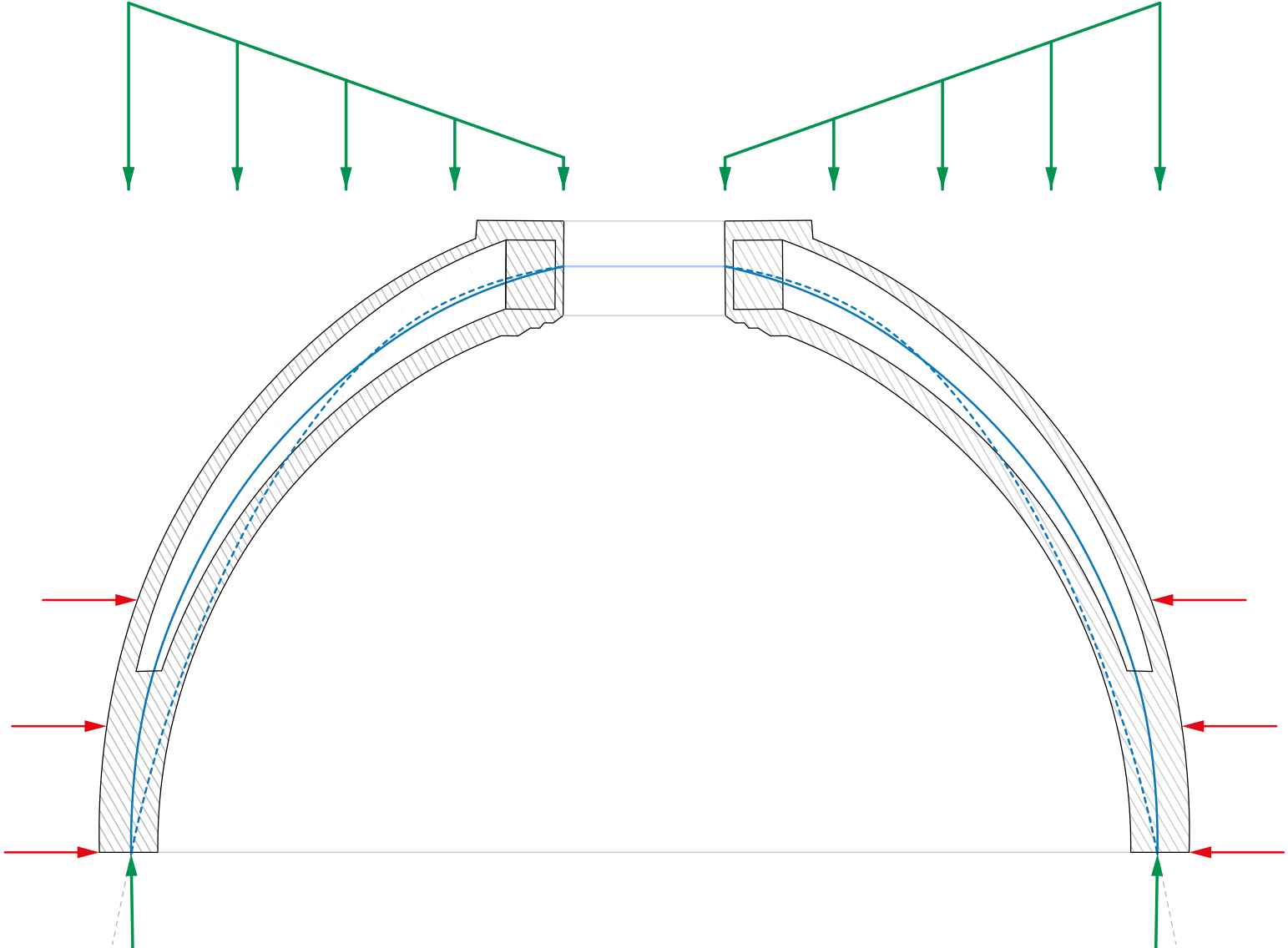

FIG. XIV.



Giovanni Poleni, 1748: Analysis of the Dome of St.-Peter's, Rome





Dome Saint Peter's Basilica



Pantheon, Rome, Italy, 125 AD

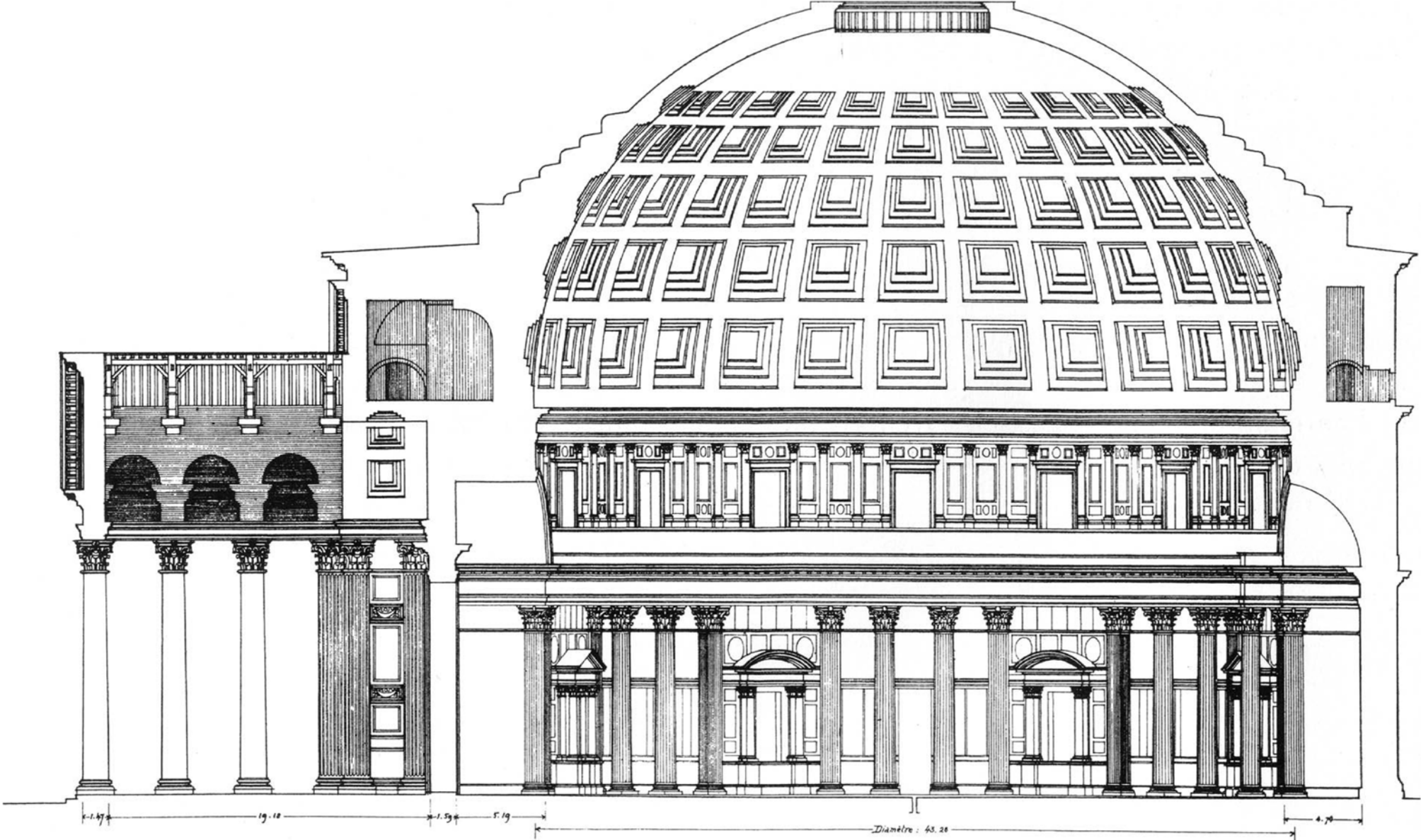

Pantheon, Rome, Italy, 125 AD

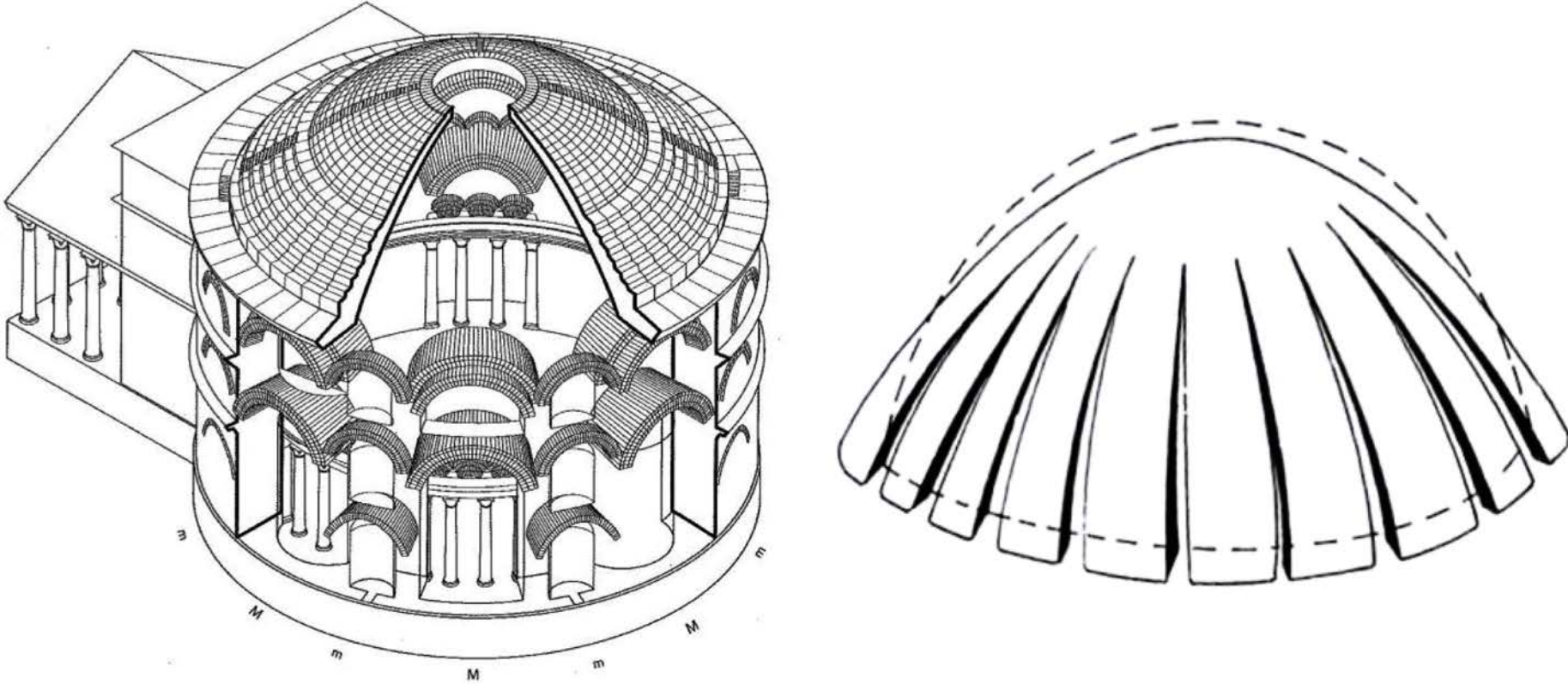

Pantheon, Rome, Italy, 125 AD

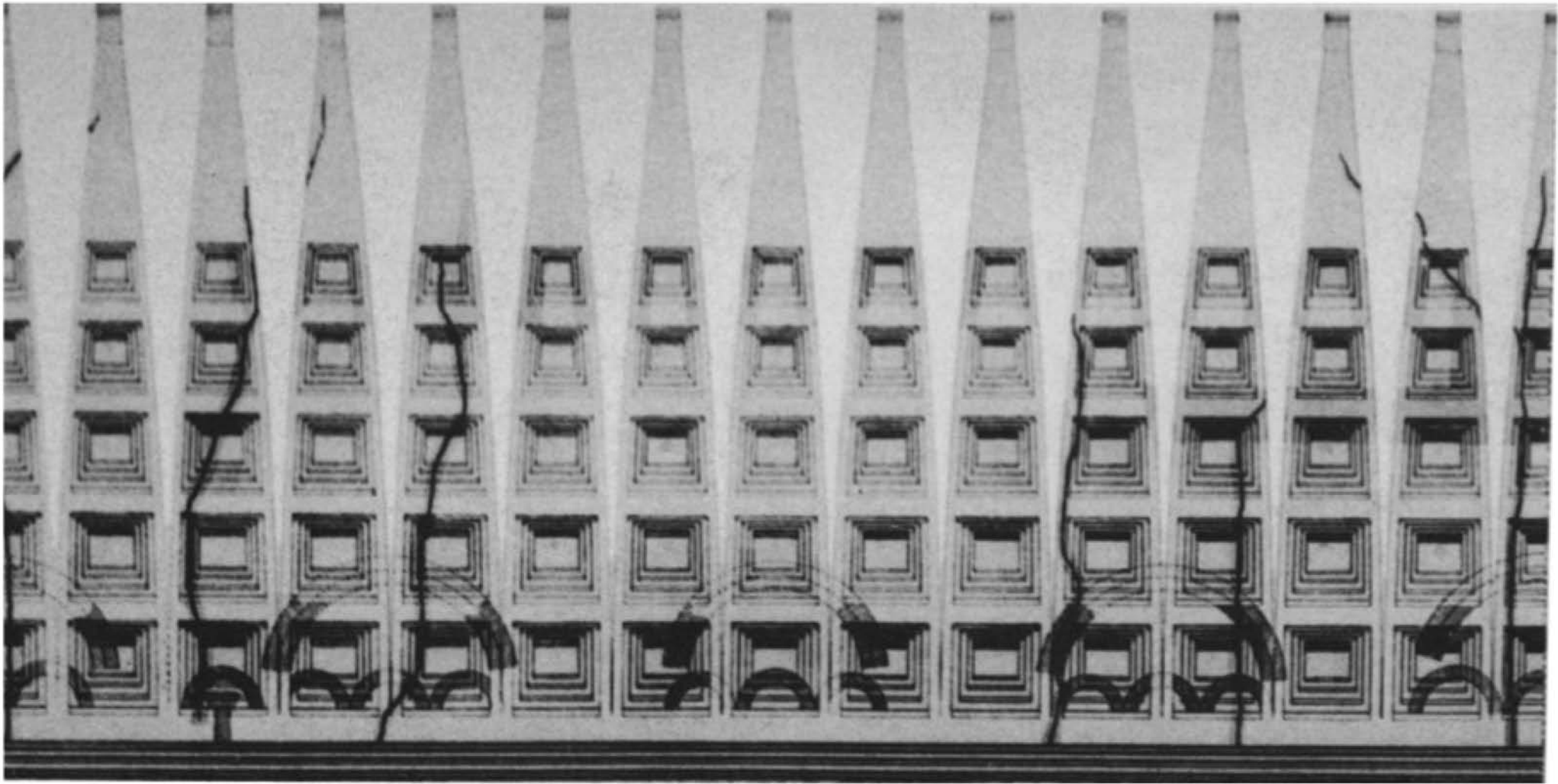

Pantheon, Rome, Italy, 125 AD

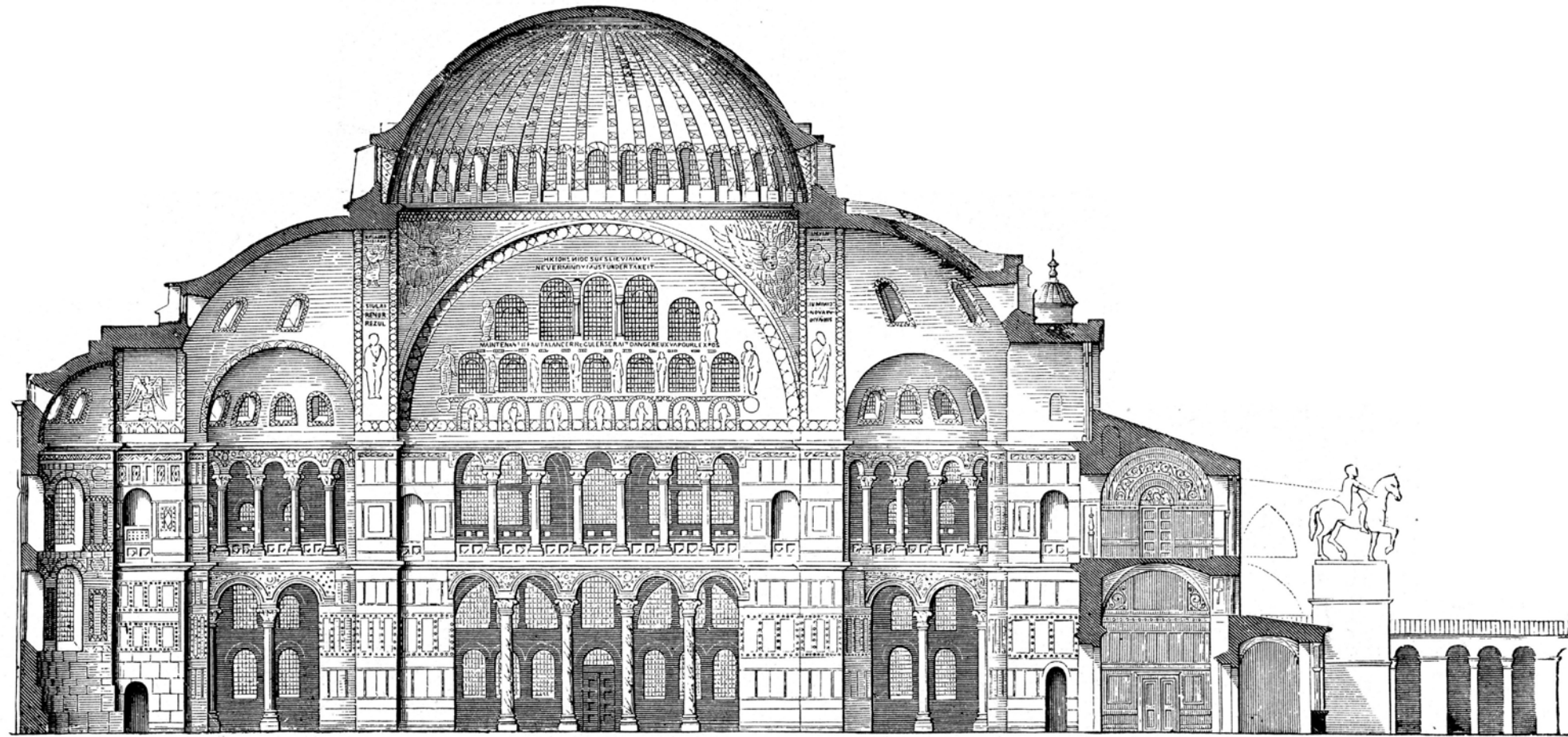

Hagia Sophia, Istanbul, Turkey, 6th Century



Hagia Sophia, Istanbul, Turkey, 6th Century