

# Tragwerksentwurf I

## *Structural Design I*

Philippe Block · Joseph Schwartz



Tragwerksentwurf  
*Structural Design*



1. Gleichgewicht  
*1. Equilibrium*

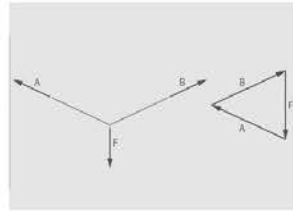

2. Graphische Statik  
*2. Graphic statics*



3. Seile  
*3. Cables*



4. Bogen  
*4. Arches*



5. Bogen-Seil  
*5. Arch-cables*

## Tragwerksentwurf I *Structural Design I*

## Tragwerksentwurf II *Structural Design II*

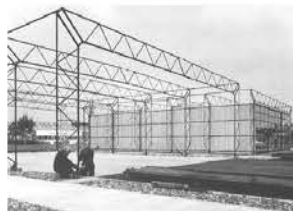

6. Fachwerke  
*6. Trusses*



7. Balken  
*7. Beams*



8. Rahmen  
*8. Frames*



9. Platten  
*9. Plates*



10. Stützen  
*10. Columns*



11. Nachhaltigkeit  
*11. Sustainability*



# Seile

## *Cables*

>> Tragwirkung eines Seils unter mehreren beliebigen Lasten  
*A cable's reaction to a set of non-concurrent loads*

Tragwirkung eines Seils unter gleichmässig verteilter Belastung  
*A cable's reaction to uniformly distributed loads*

Fallstudie: Golden Gate Brücke  
*Case study: Golden Gate bridge*

Formänderung von Seiltragwerken  
*Form-active behaviour of cables*

Aussteifung durch Erhöhung der Eigenlasten  
*Stiffening by increasing dead loads*

Aussteifung durch Vorspannung  
*Stiffening through prestressing*

Aussteifung mittels eines Fachwerks  
*Stiffening using a truss*

Übersicht der Aussteifungssysteme  
*Overview of stiffening schemes*

*A cable's reaction to a set of non-concurrent loads*

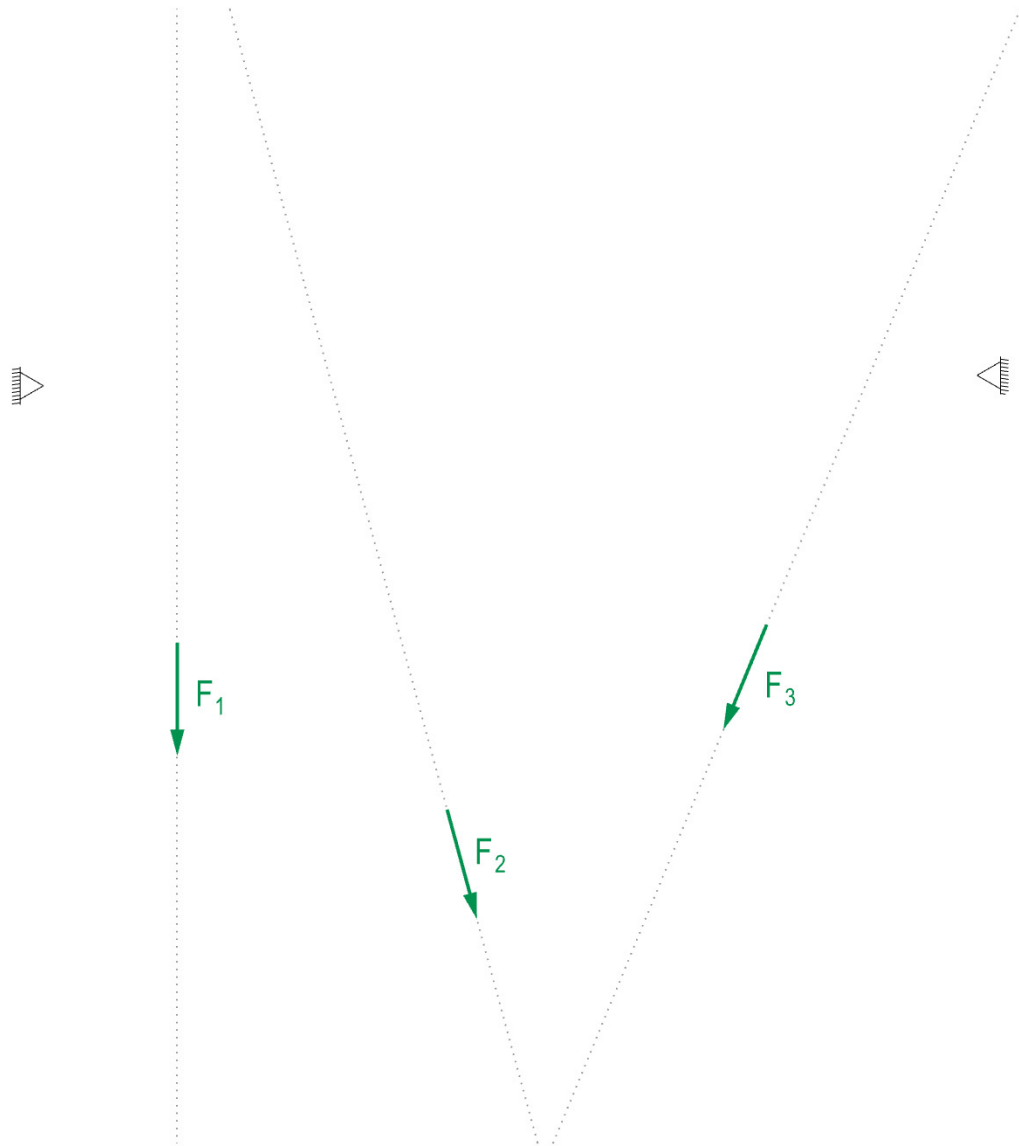

Lageplan 1:100  
*Form diagram 1:100*

Kräfteplan 1 cm  $\cong$  1 kN  
*Force diagram 1 cm  $\cong$  1 kN*

*A cable's reaction to a set of non-concurrent loads*

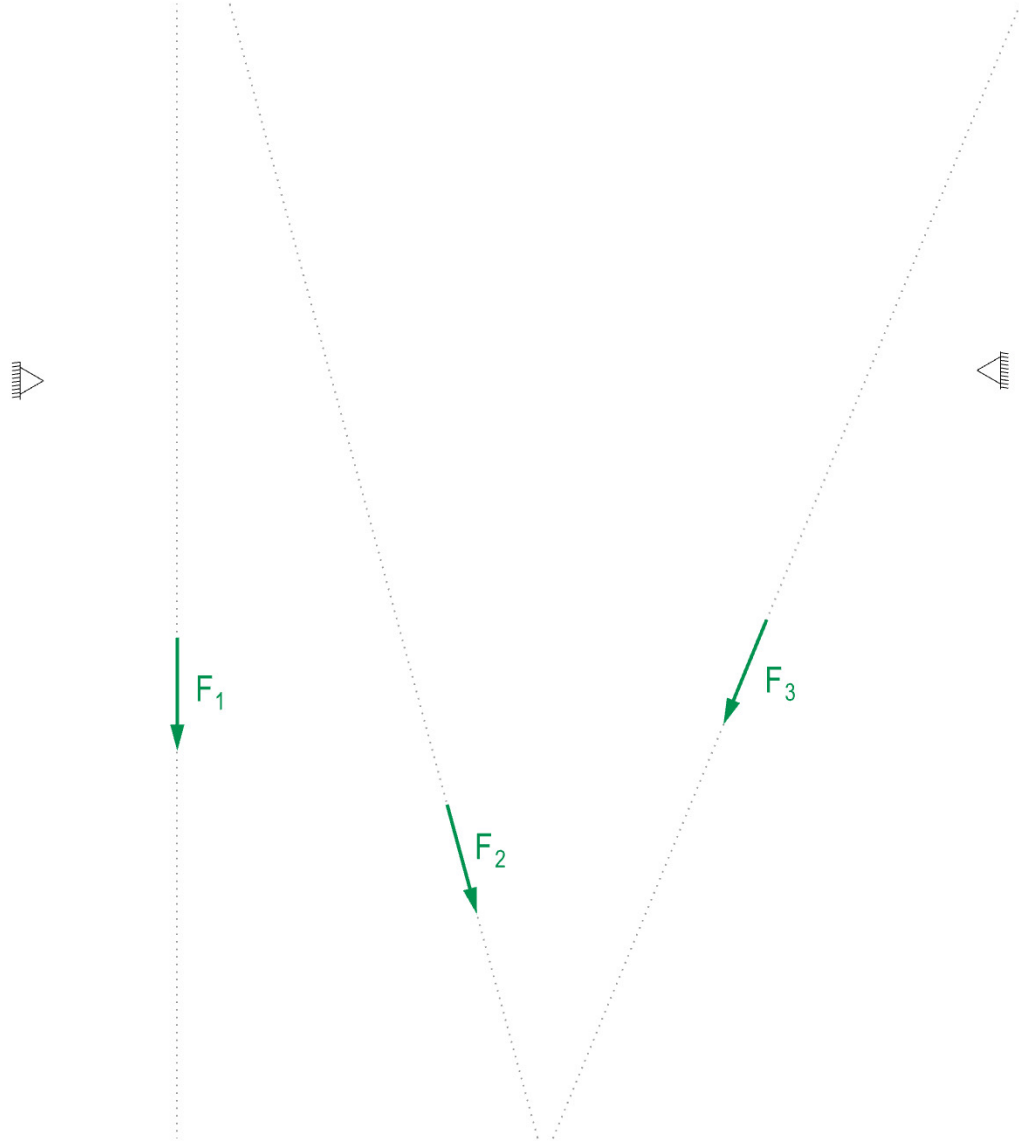

Lageplan 1:100  
*Form diagram 1:100*

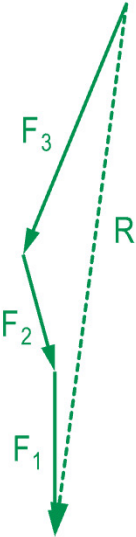

Kräfteplan 1 cm  $\cong$  1 kN  
*Force diagram 1 cm  $\cong$  1 kN*

*A cable's reaction to a set of non-concurrent loads*

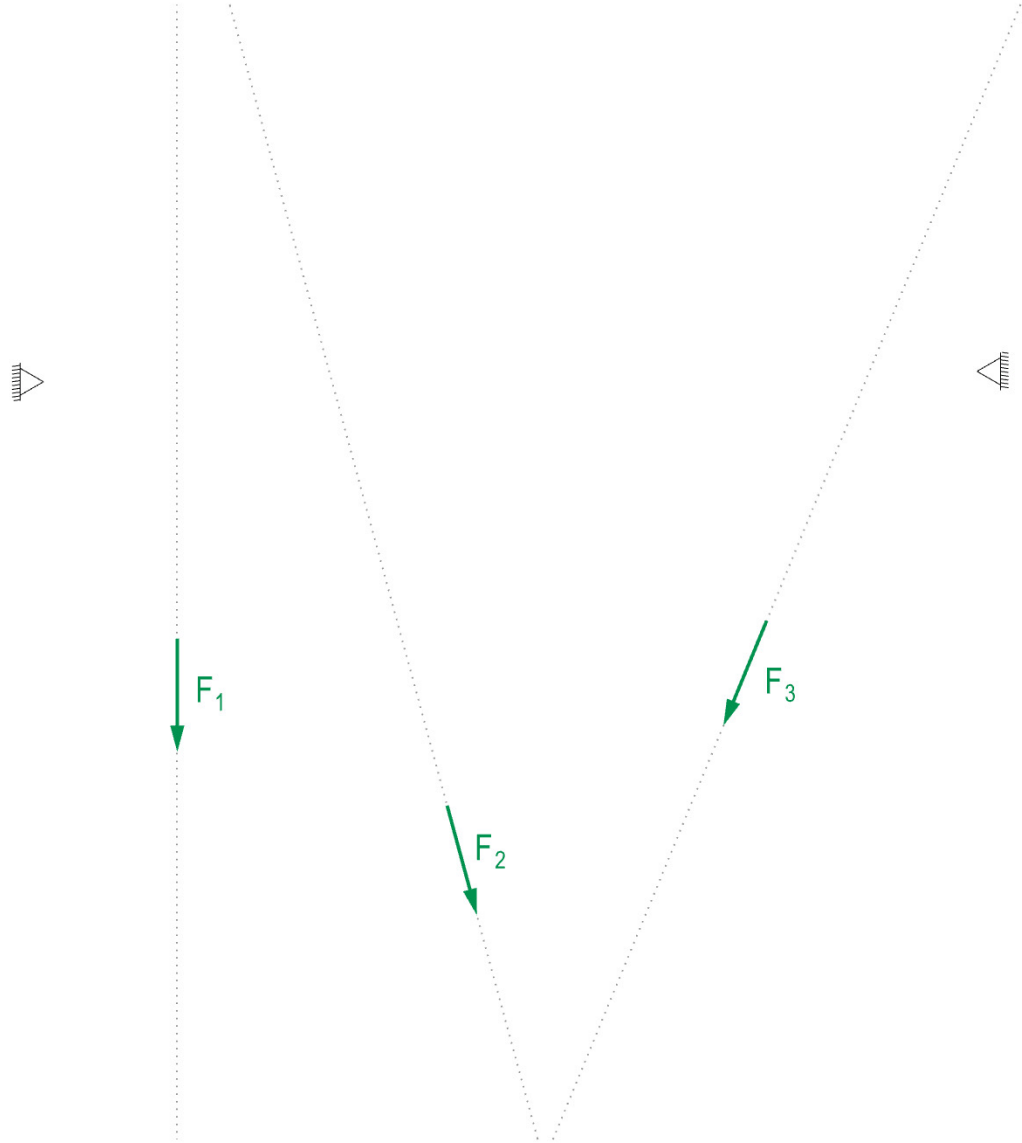

Lageplan 1:100  
*Form diagram 1:100*

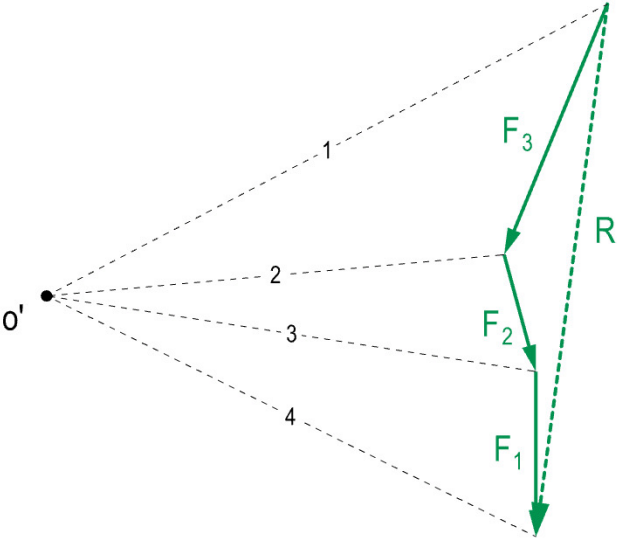

Kräfteplan 1 cm ≅ 1 kN  
*Force diagram 1 cm ≅ 1 kN*

*A cable's reaction to a set of non-concurrent loads*

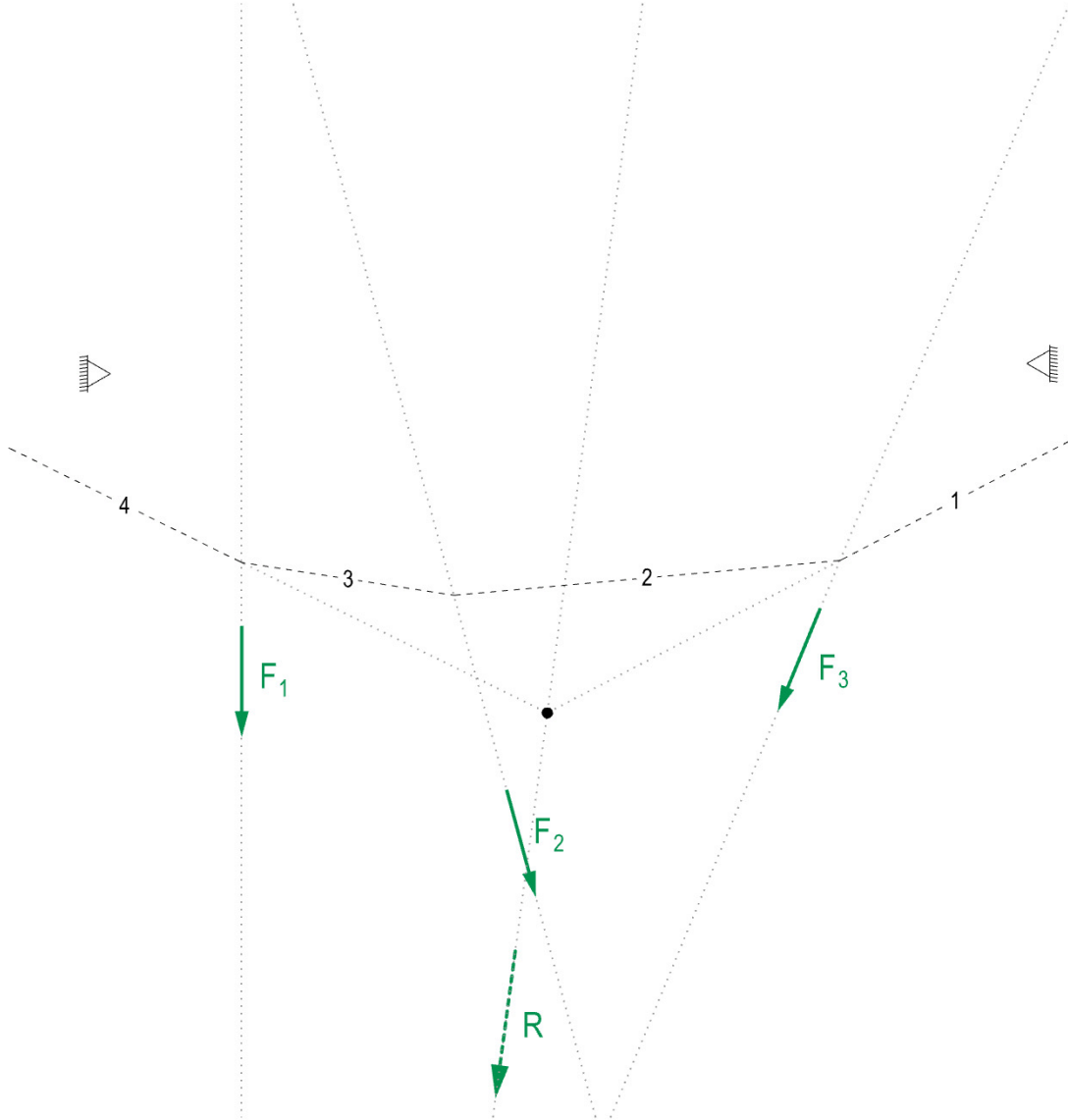

Lageplan 1:100  
*Form diagram 1:100*

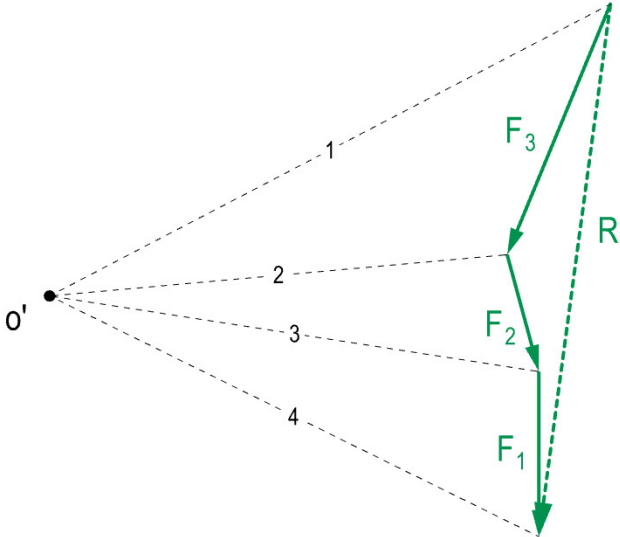

Kräfteplan 1 cm  $\cong$  1 kN  
*Force diagram 1 cm  $\cong$  1 kN*

*A cable's reaction to a set of non-concurrent loads*

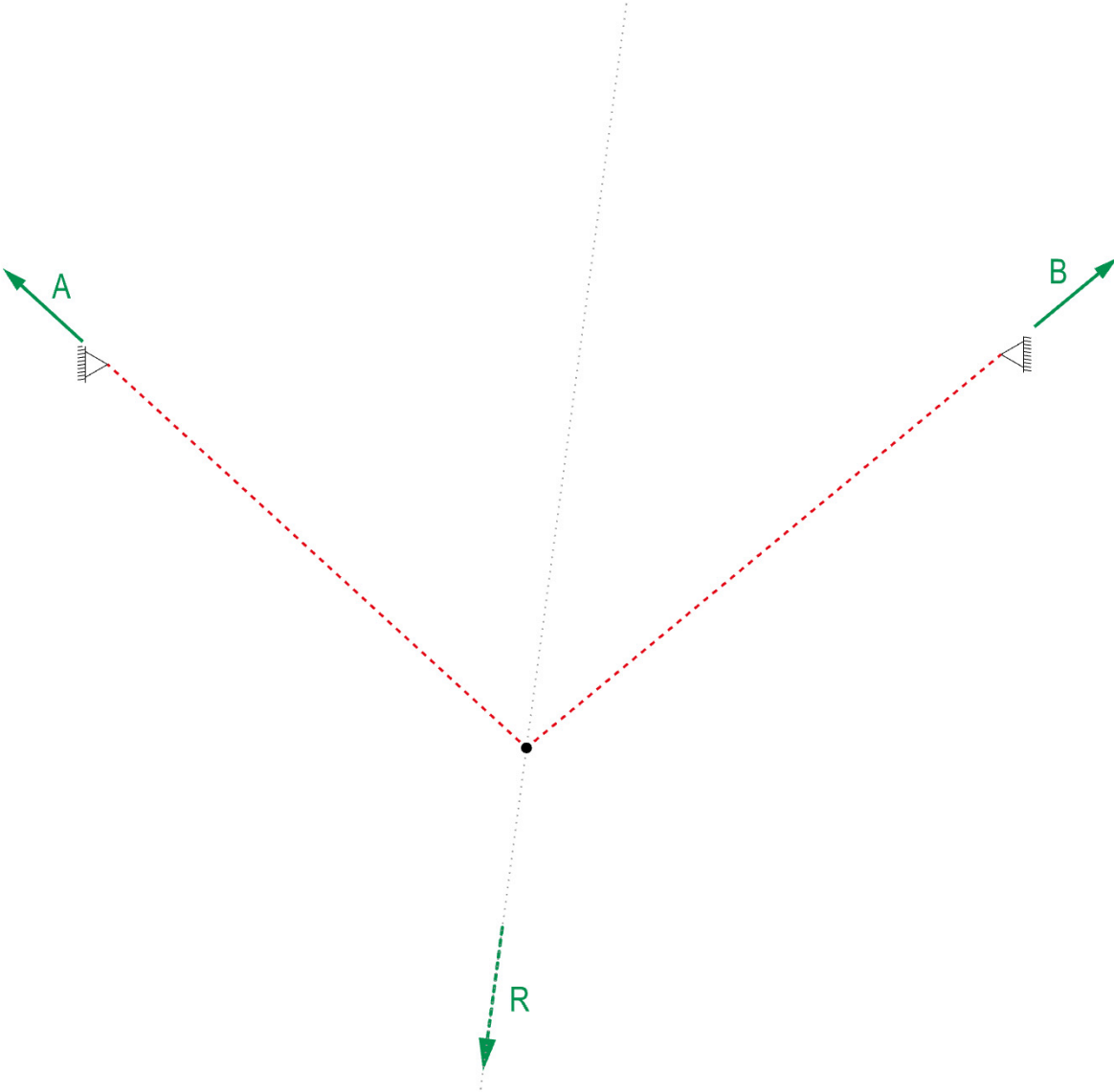

Lageplan 1:100  
*Form diagram 1:100*

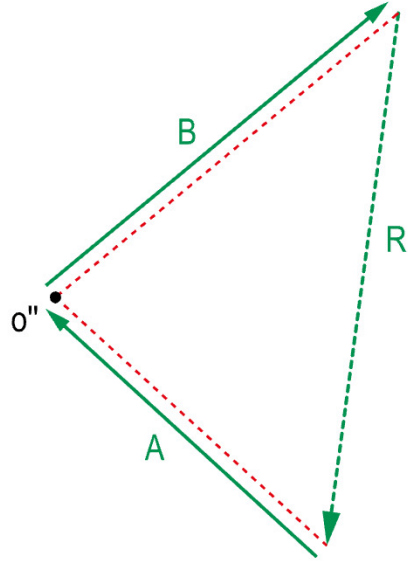

Kräfteplan 1 cm ≅ 1 kN  
*Force diagram 1 cm ≅ 1 kN*

*A cable's reaction to a set of non-concurrent loads*

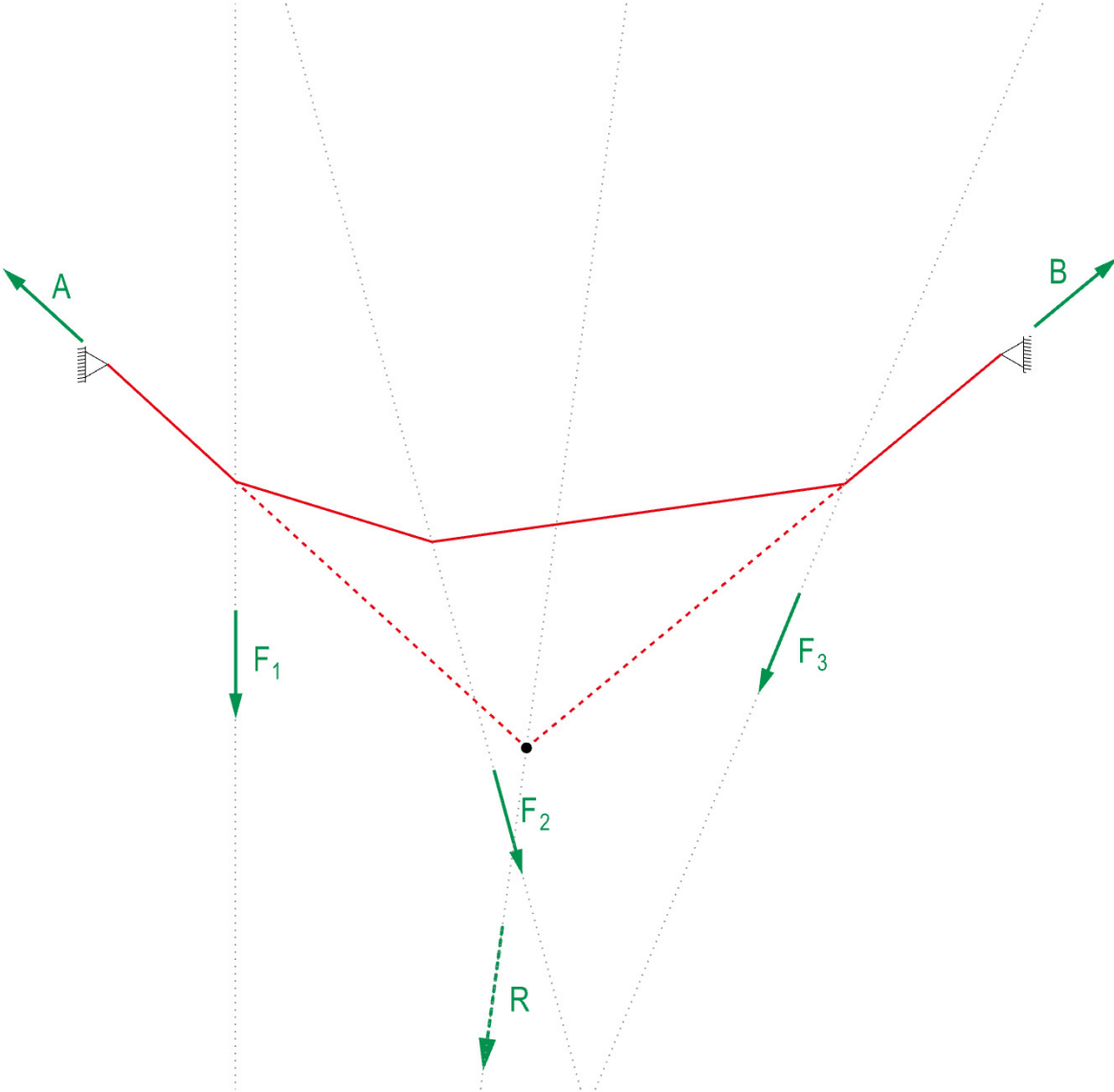

Lageplan 1:100  
*Form diagram 1:100*

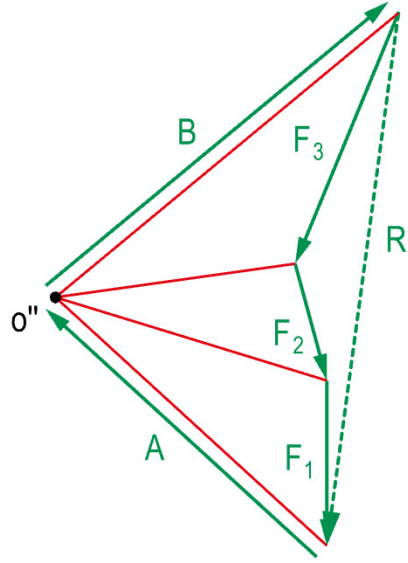

Kräfteplan 1 cm  $\cong$  1 kN  
*Force diagram 1 cm  $\cong$  1 kN*



*A cable's reaction to a set of non-concurrent loads*

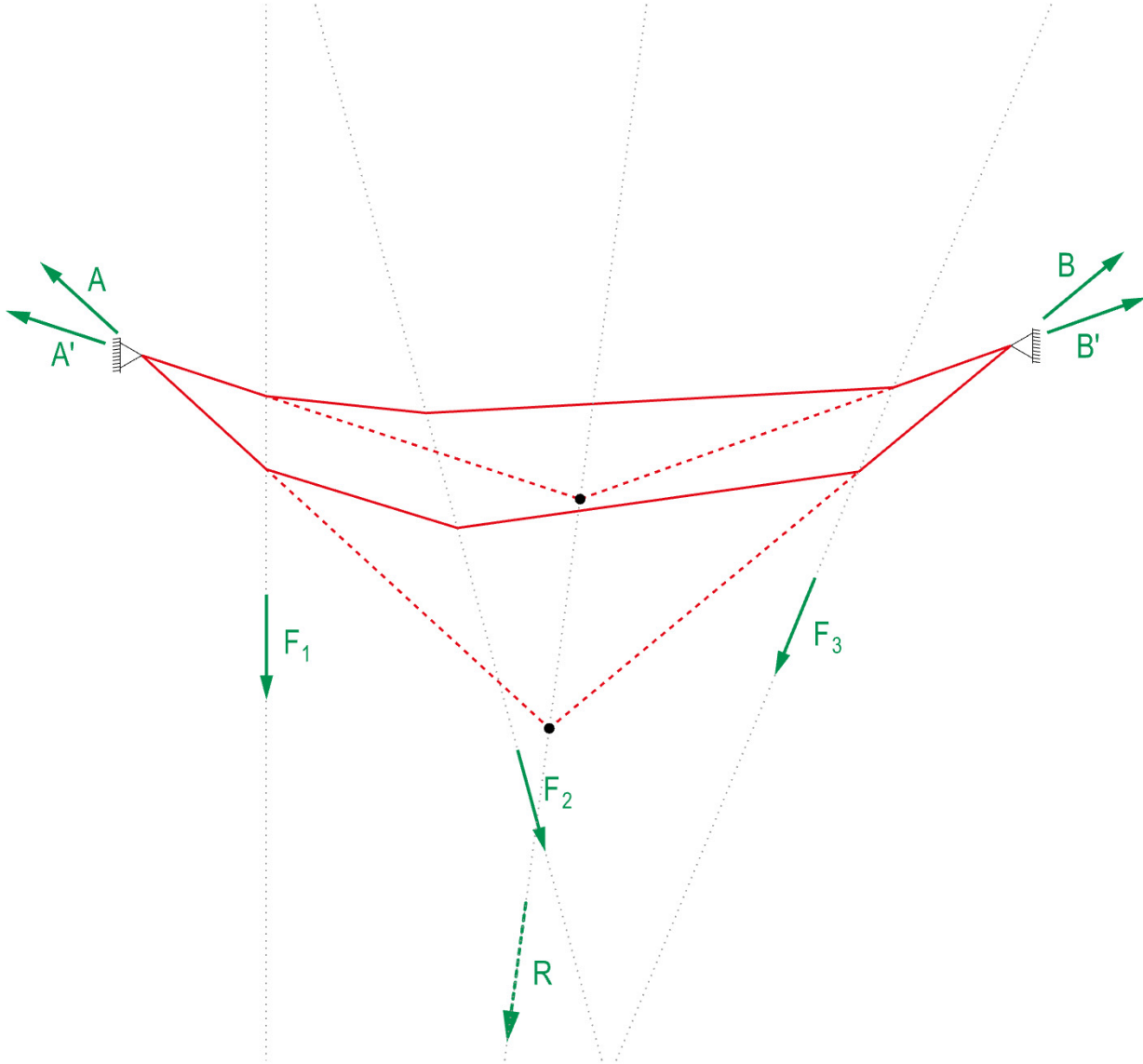

Lageplan 1:100  
*Form diagram 1:100*

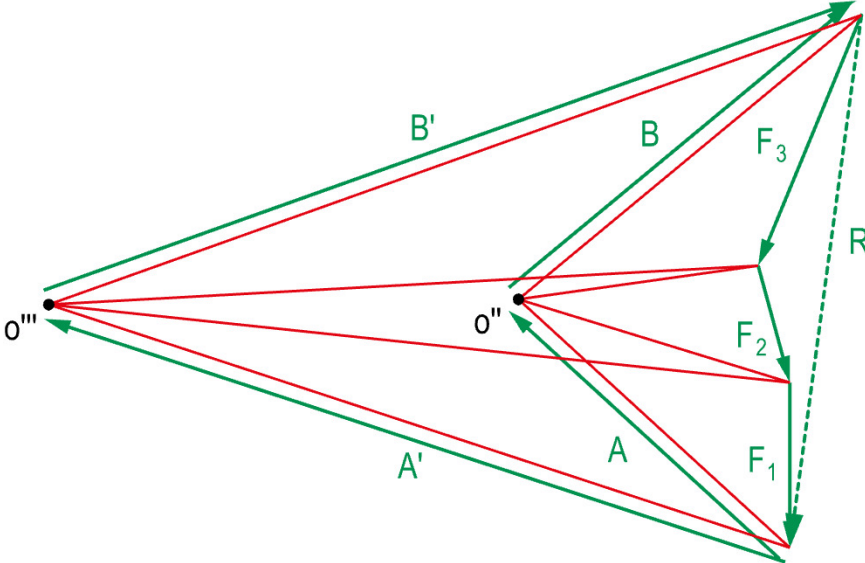

Kräfteplan 1 cm ≅ 1 kN  
*Force diagram 1 cm ≅ 1 kN*

*A cable's reaction to a set of non-concurrent loads*

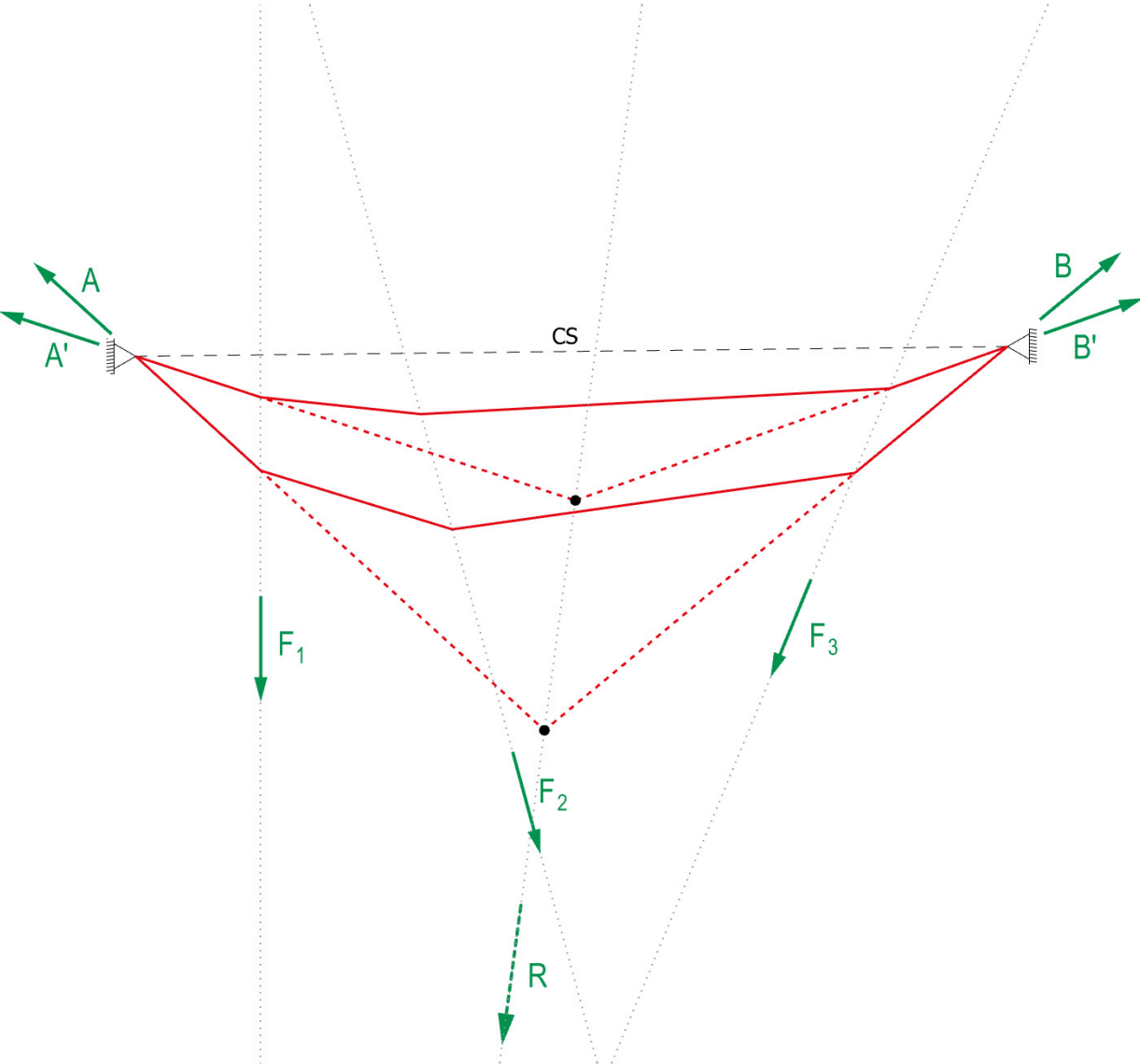

Lageplan 1:100  
*Form diagram 1:100*

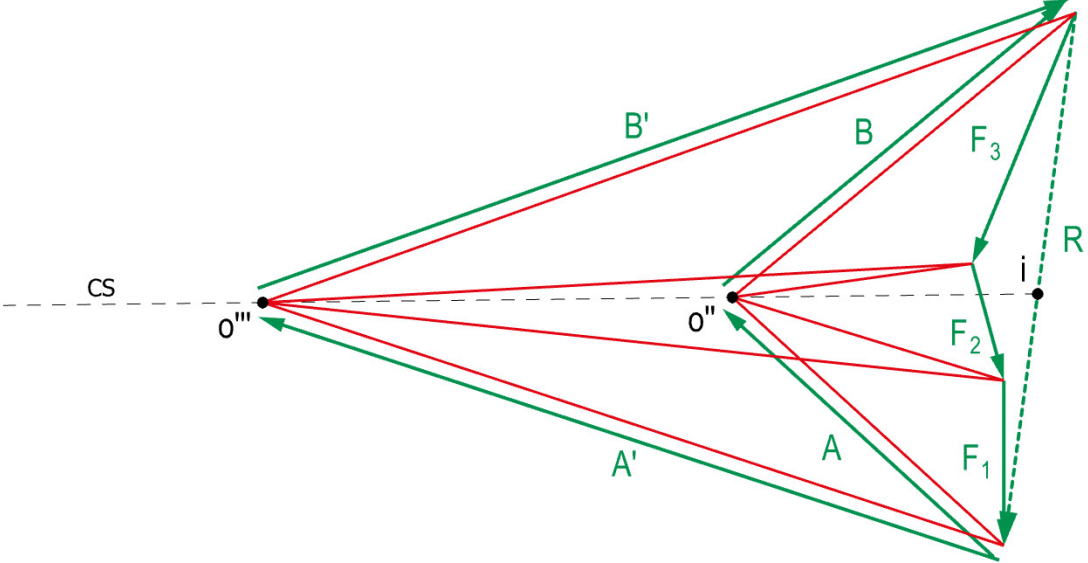

Kräfteplan 1 cm ≅ 1 kN  
*Force diagram 1 cm ≅ 1 kN*

*A cable's reaction to a set of non-concurrent loads*

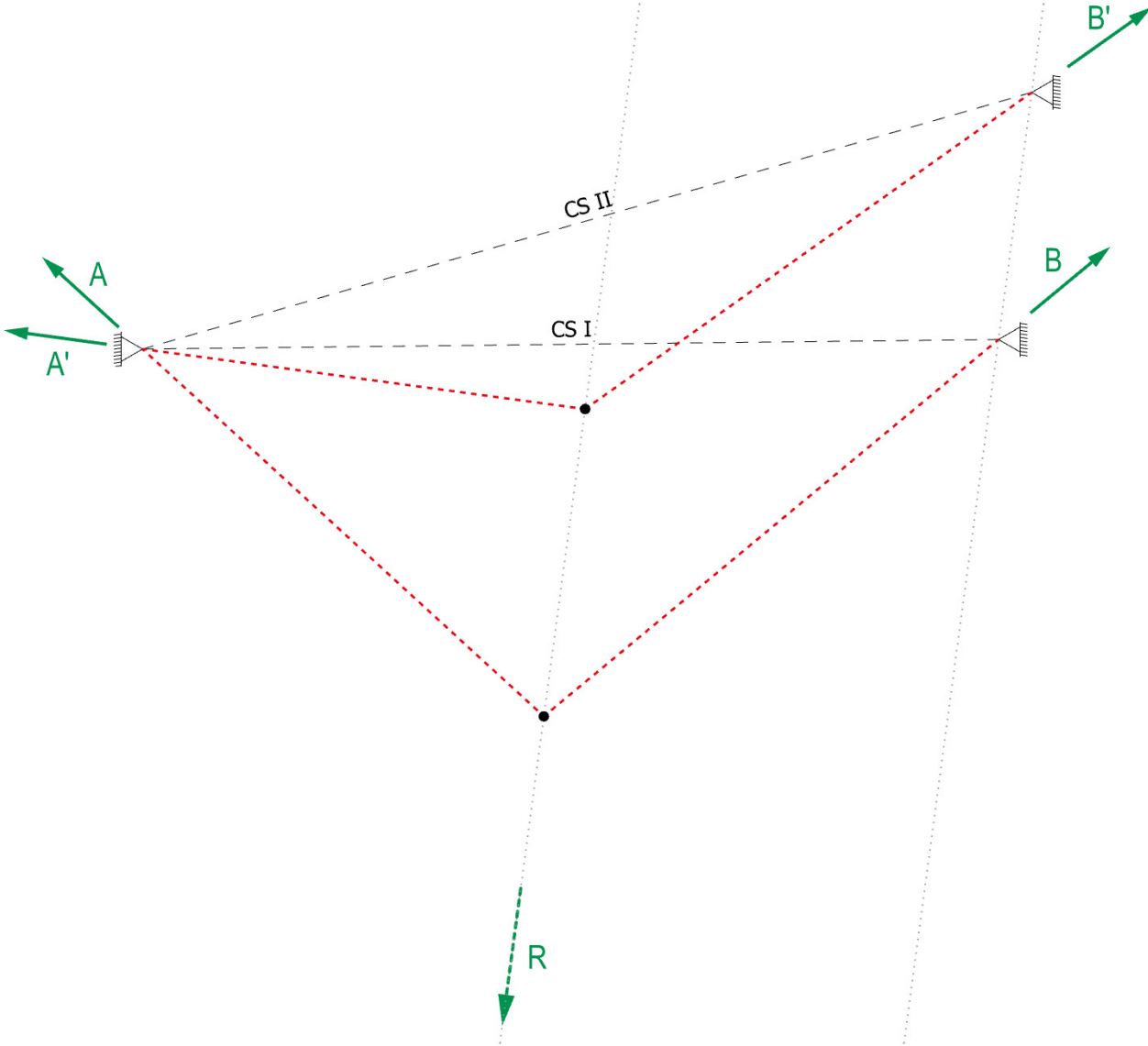

Lageplan 1:100  
*Form diagram 1:100*

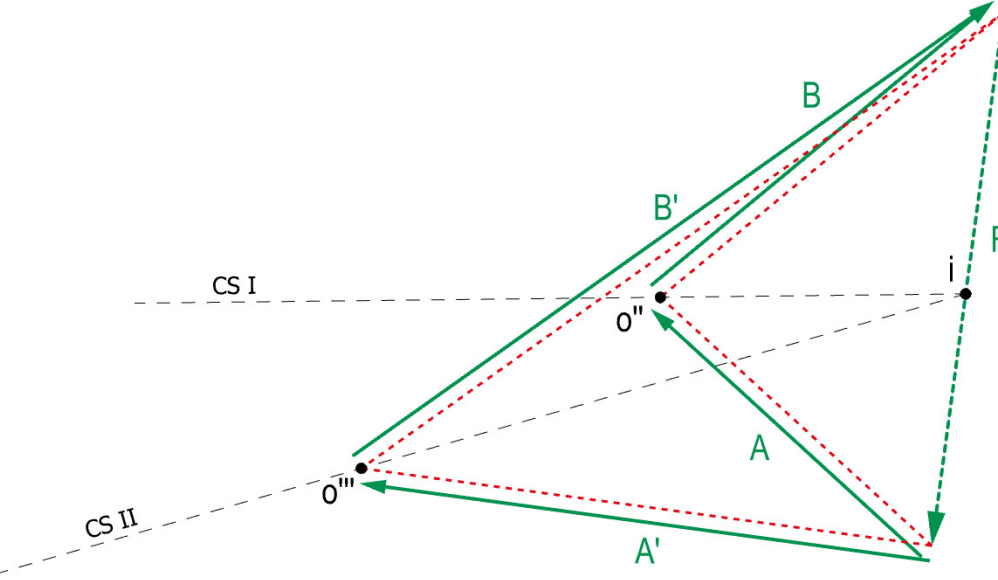

Kräfteplan 1 cm ≅ 1 kN  
*Force diagram 1 cm ≅ 1 kN*

*A cable's reaction to a set of non-concurrent loads*

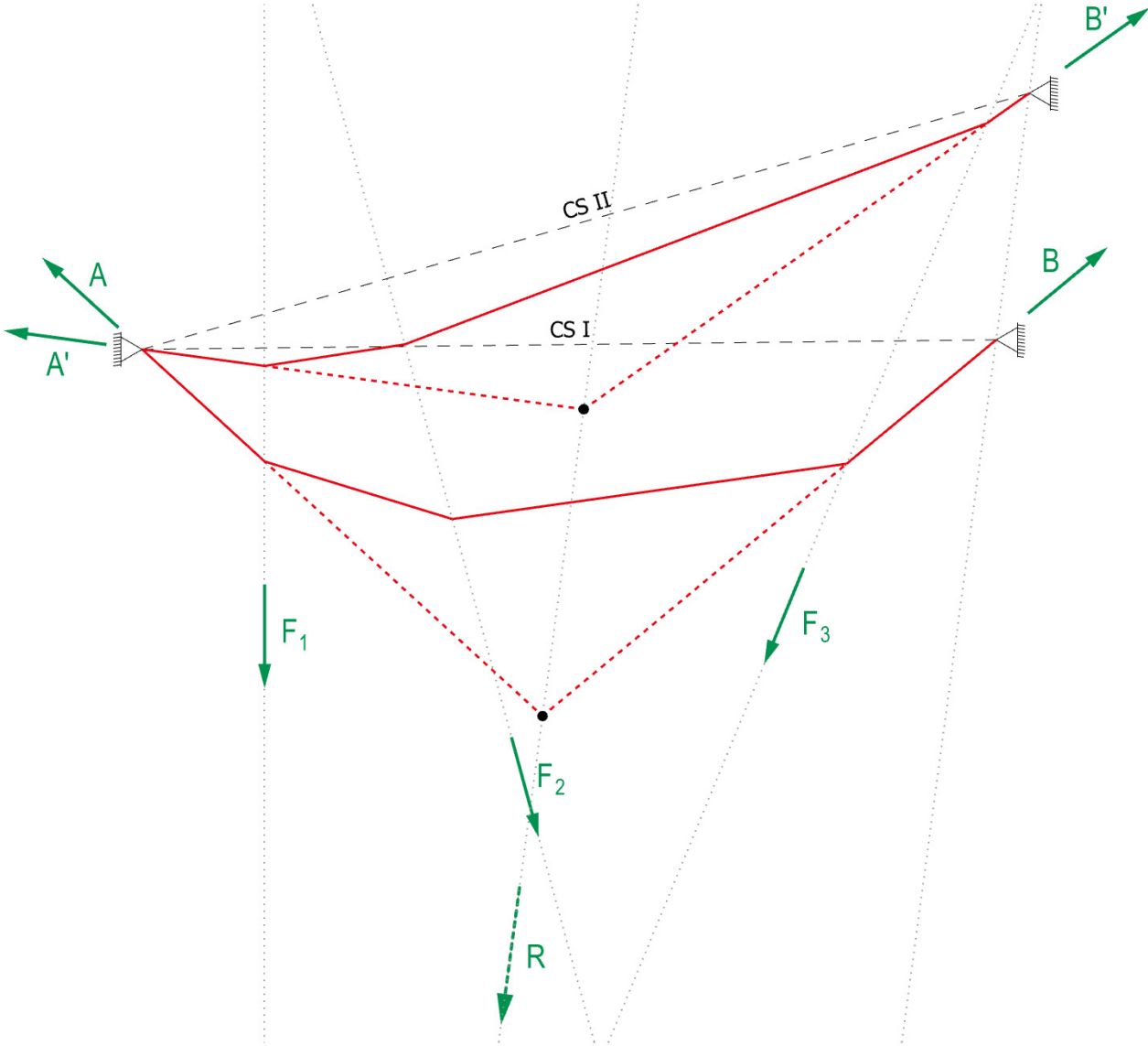

Lageplan 1:100  
*Form diagram 1:100*

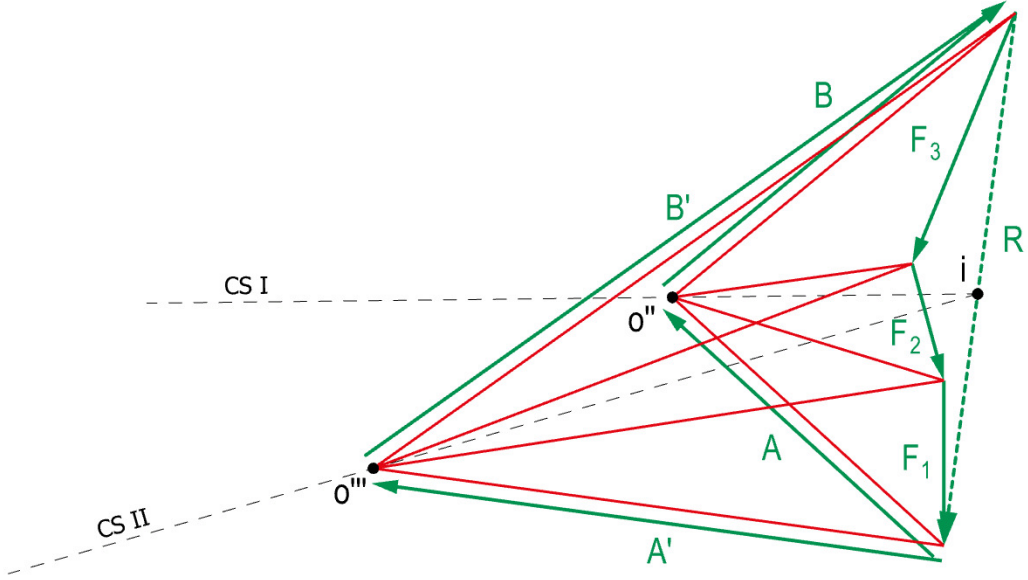

Kräfteplan 1 cm ≙ 1 kN  
*Force diagram 1 cm ≙ 1 kN*

eQ: Funicular line through two points

Form Diagram

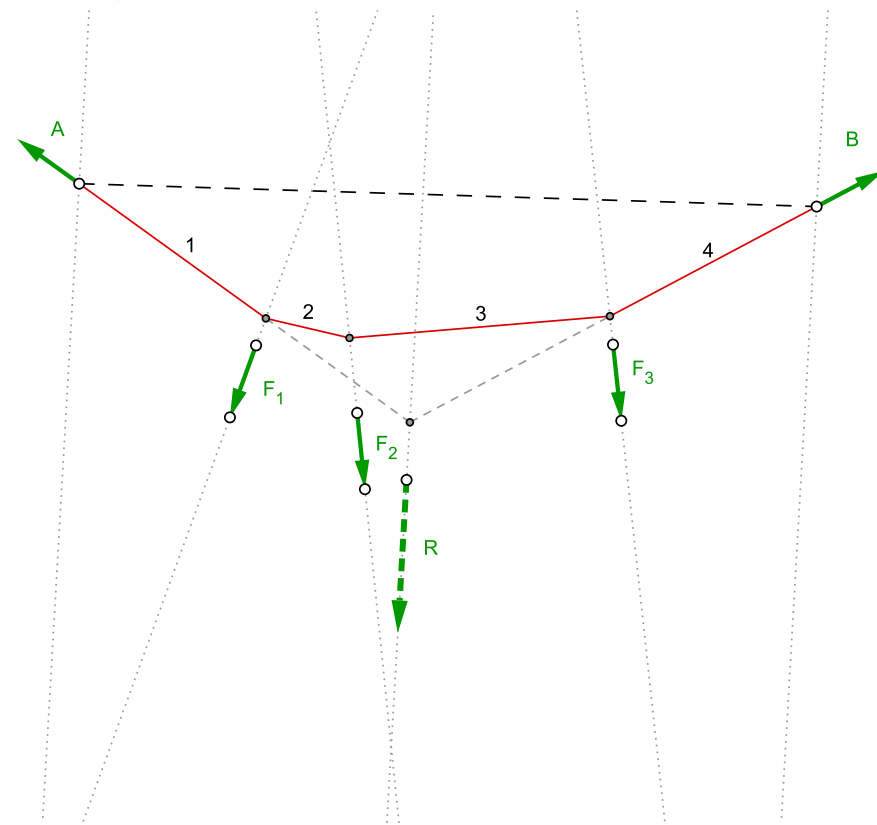

Force Diagram

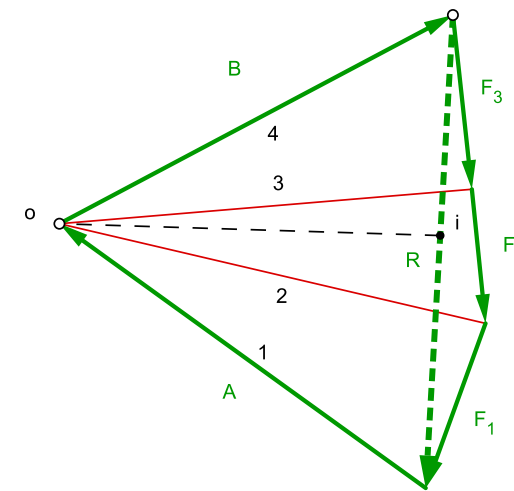

<http://www.block.arch.ethz.ch/eq/drawing/view/5>

# Seile

## *Cables*

Tragwirkung eines Seils unter mehreren beliebigen Lasten

*A cable's reaction to a set of non-concurrent loads*

>> Tragwirkung eines Seils unter gleichmässig verteilter Belastung

*A cable's reaction to uniformly distributed loads*

Fallstudie: Golden Gate Brücke

*Case study: Golden Gate bridge*

Formänderung von Seiltragwerken

*Form-active behaviour of cables*

Aussteifung durch Erhöhung der Eigenlasten

*Stiffening by increasing dead loads*

Aussteifung durch Vorspannung

*Stiffening through prestress*

Aussteifung mittels eines Fachwerks

*Stiffening using a truss*

Übersicht der Aussteifungssysteme

*Overview of stiffening schemes*

*A cable's reaction to uniformly distributed loads*

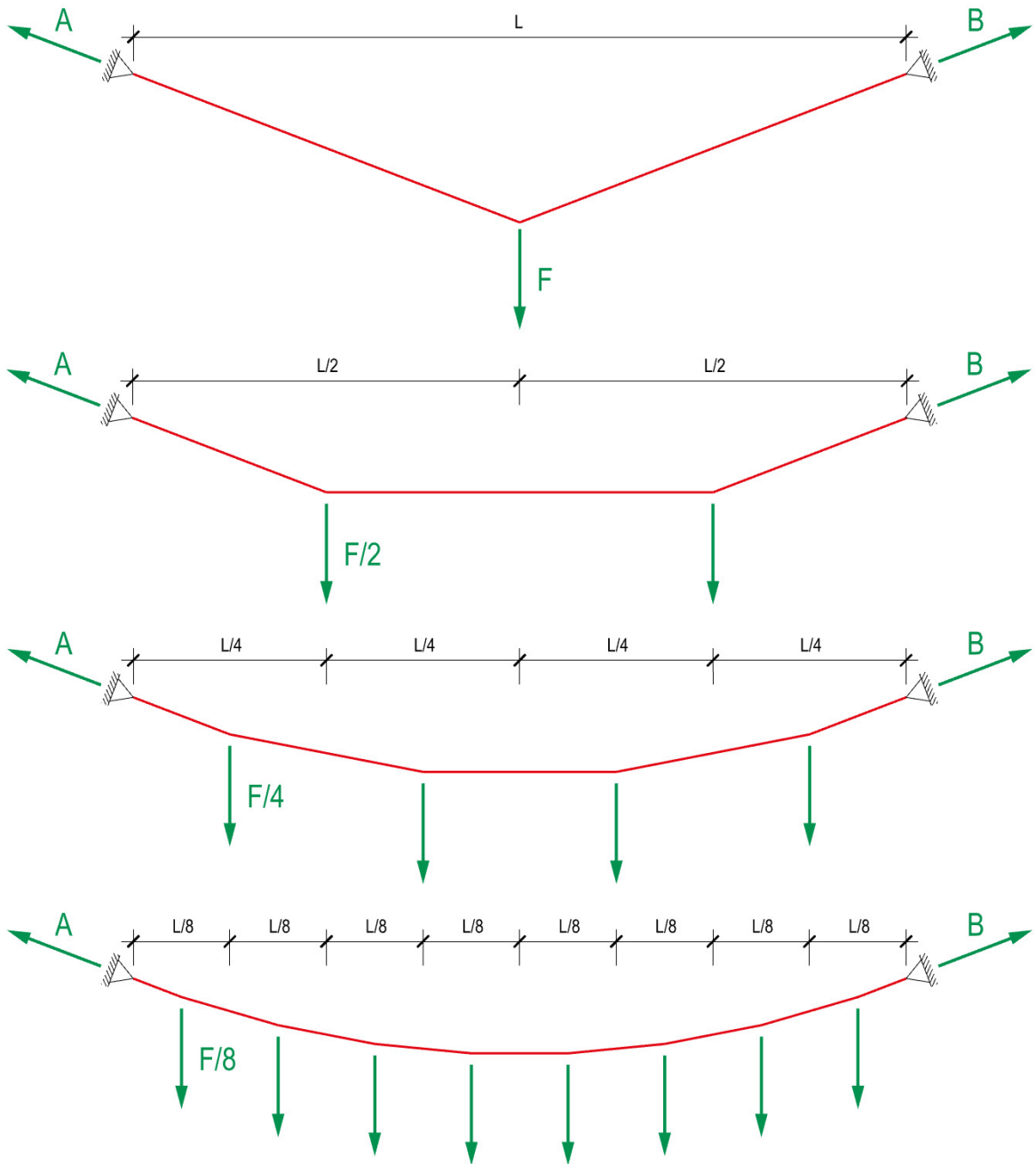

Lageplan  
*Form diagram*

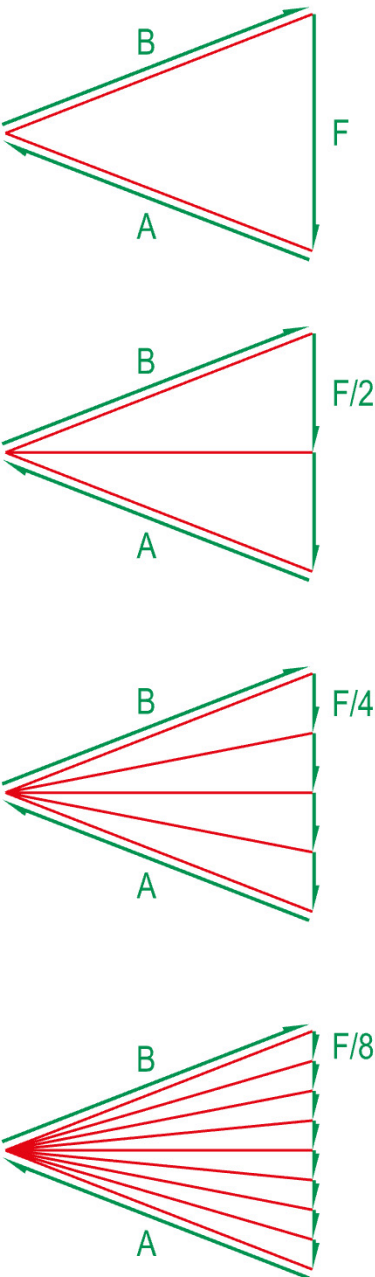

Kräfteplan  
*Force diagram*



*A cable's reaction to uniformly distributed loads*

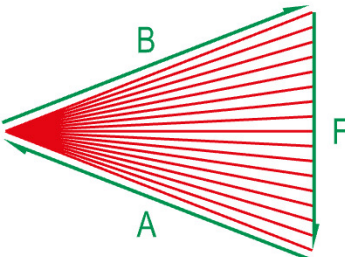
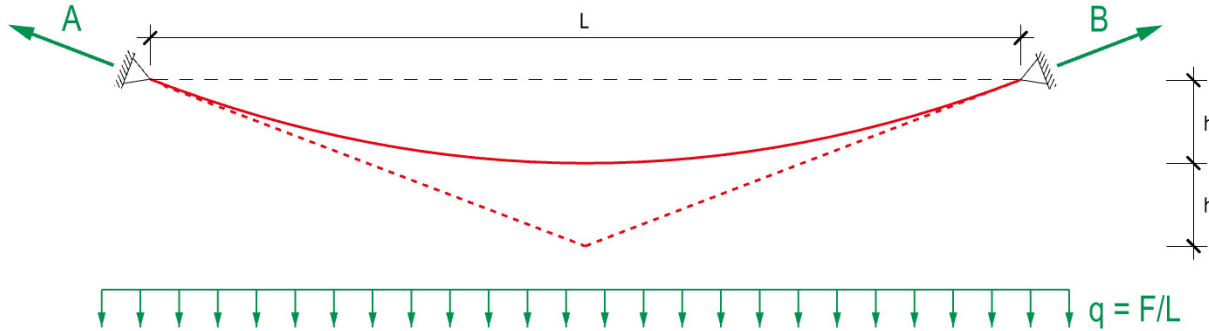
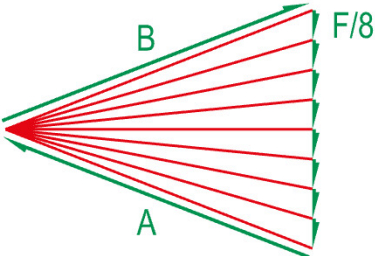
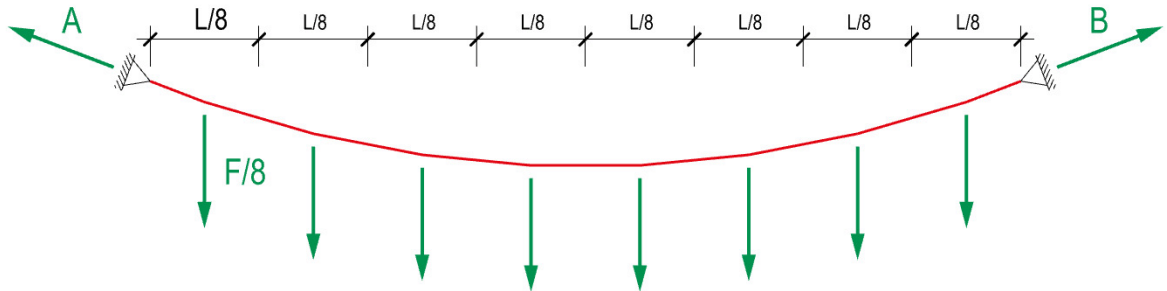

Lageplan  
*Form diagram*

Kräfteplan  
*Force diagram*

*A cable's reaction to uniformly distributed loads*

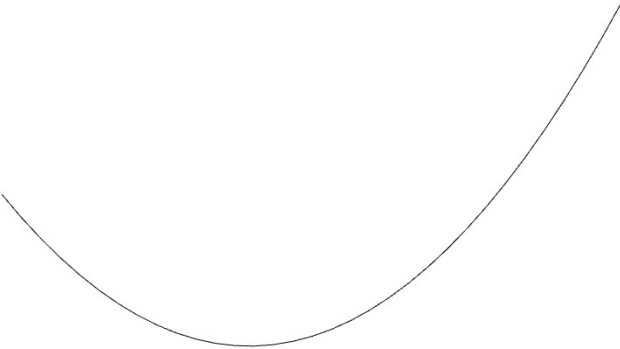

*A cable's reaction to uniformly distributed loads*

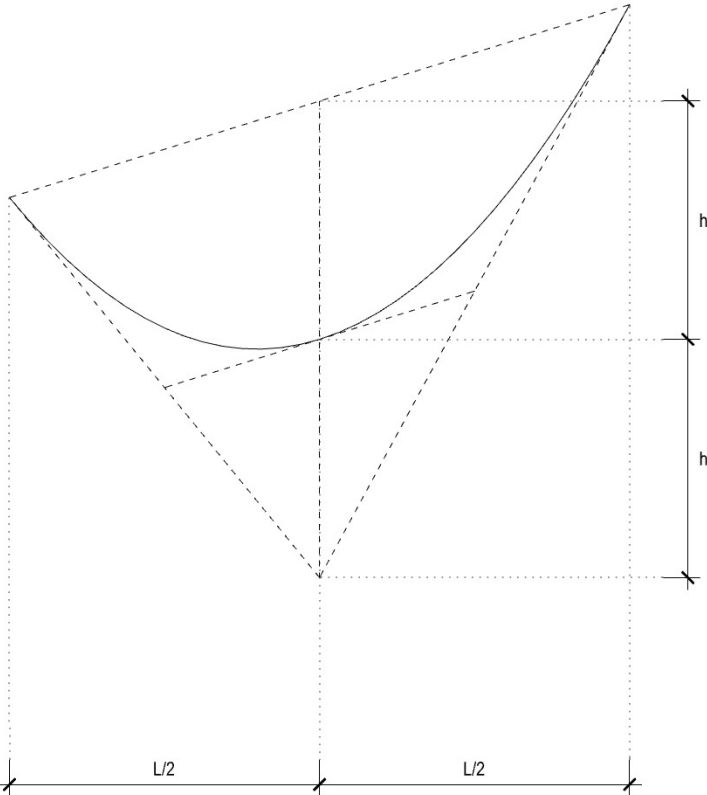
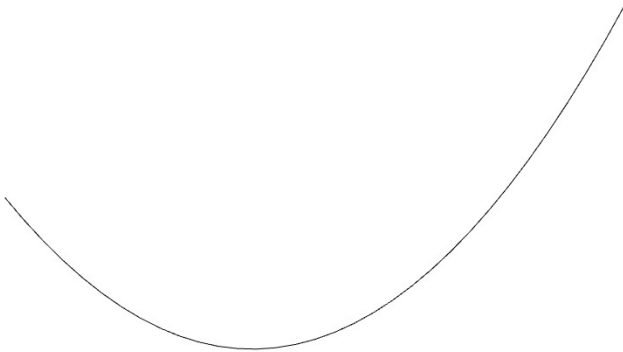

*A cable's reaction to uniformly distributed loads*

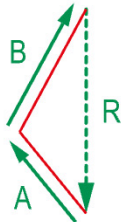
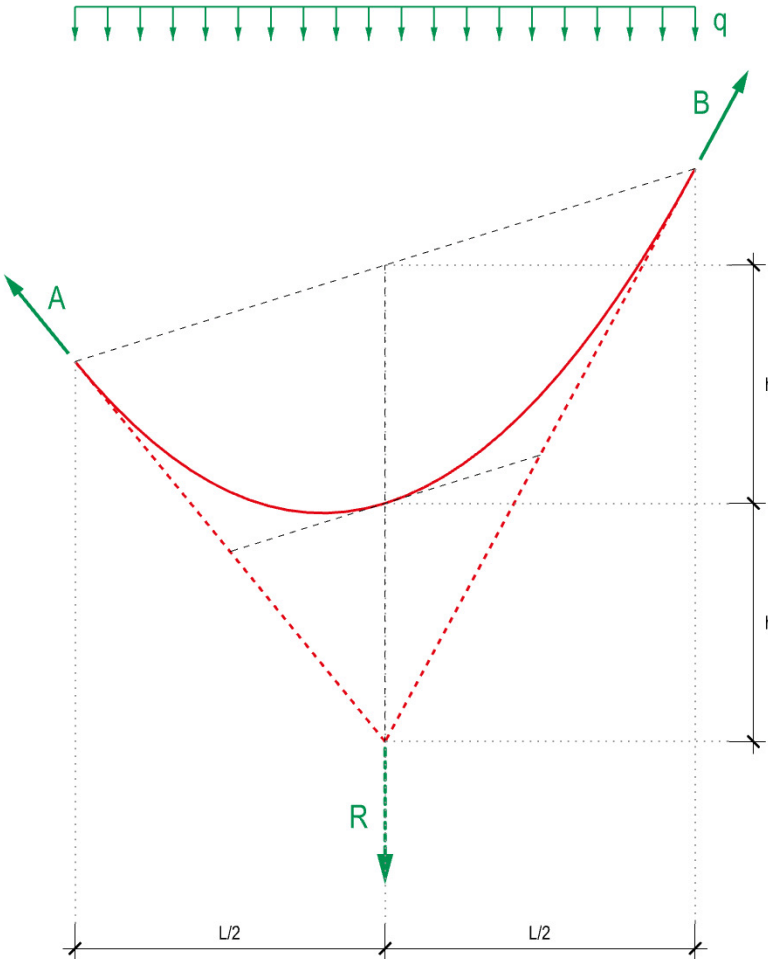
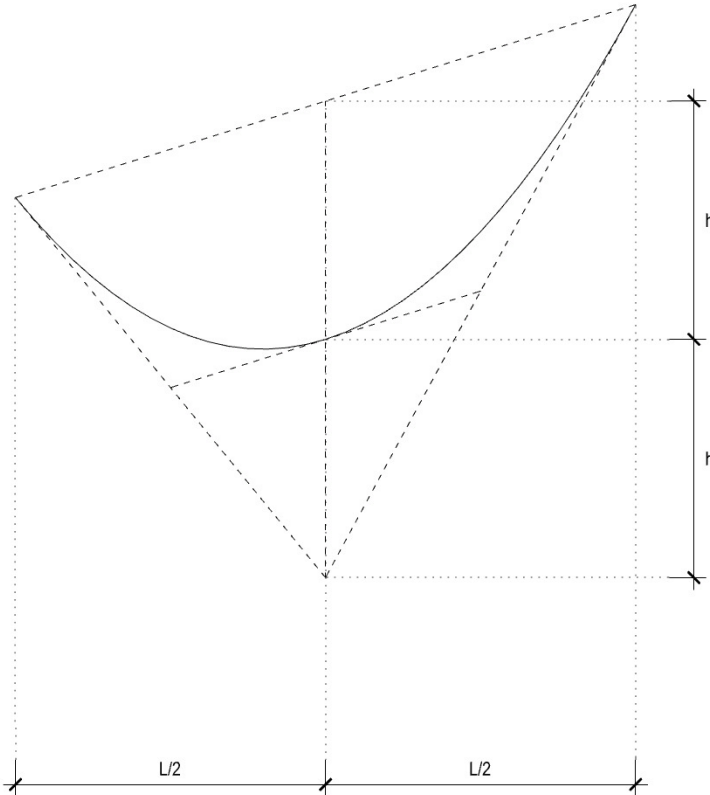
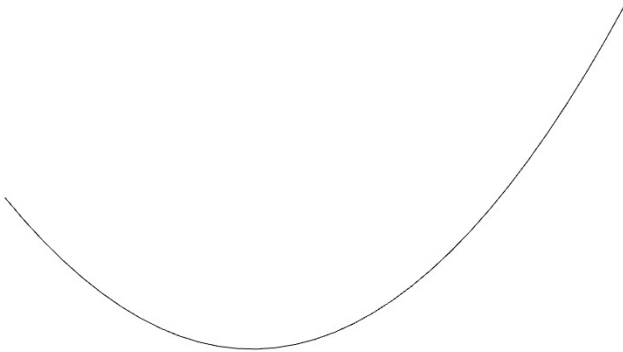







Alvaro Siza, Cecil Balmond: Expo Pavillion of Portugal, Lisbon, 1998

*A cable's reaction to uniformly distributed loads*

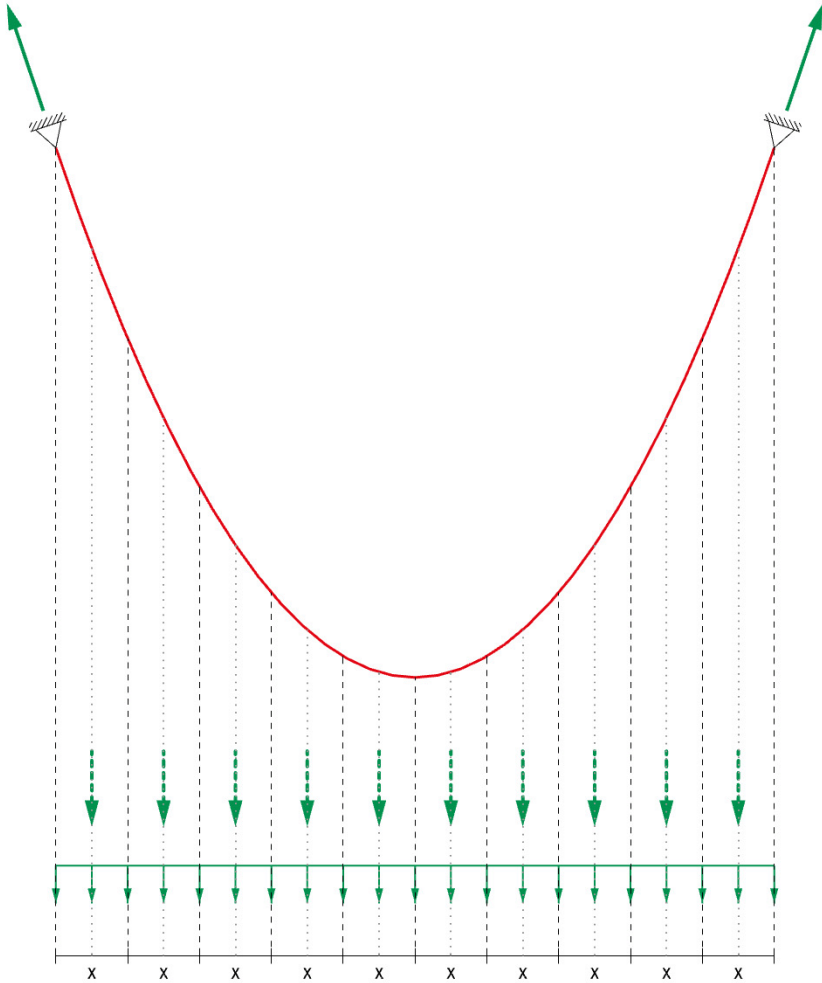

Parabel  
*Parabola*

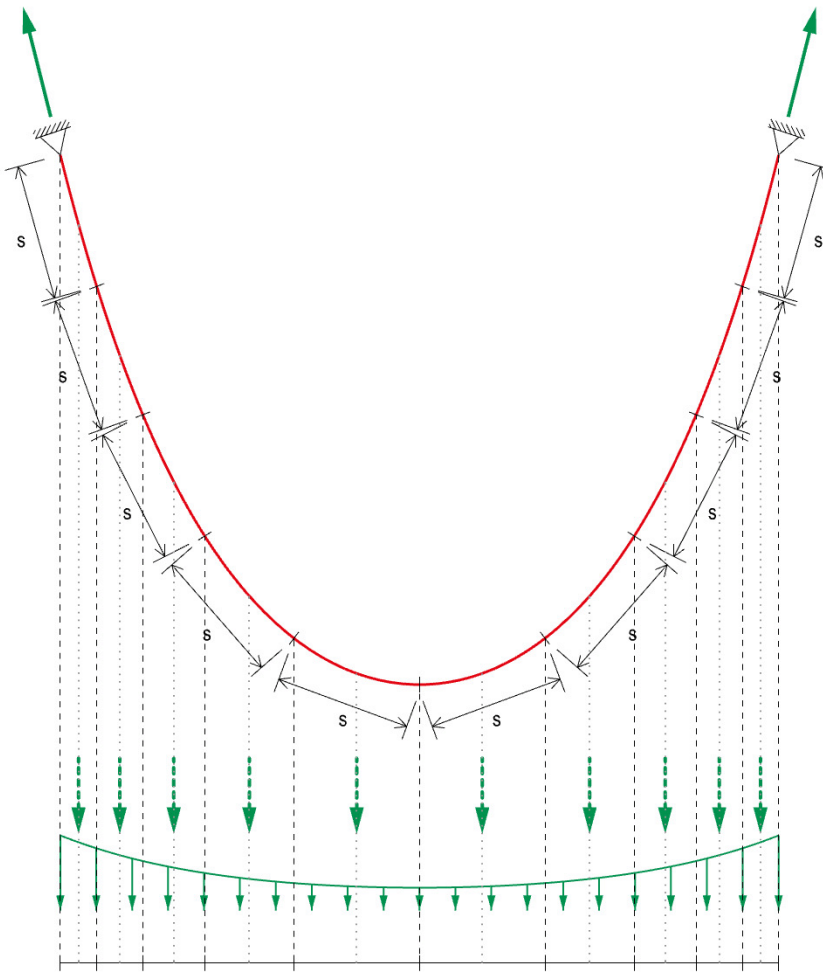

Kettenlinie  
*Catenary*



*A cable's reaction to uniformly distributed loads*

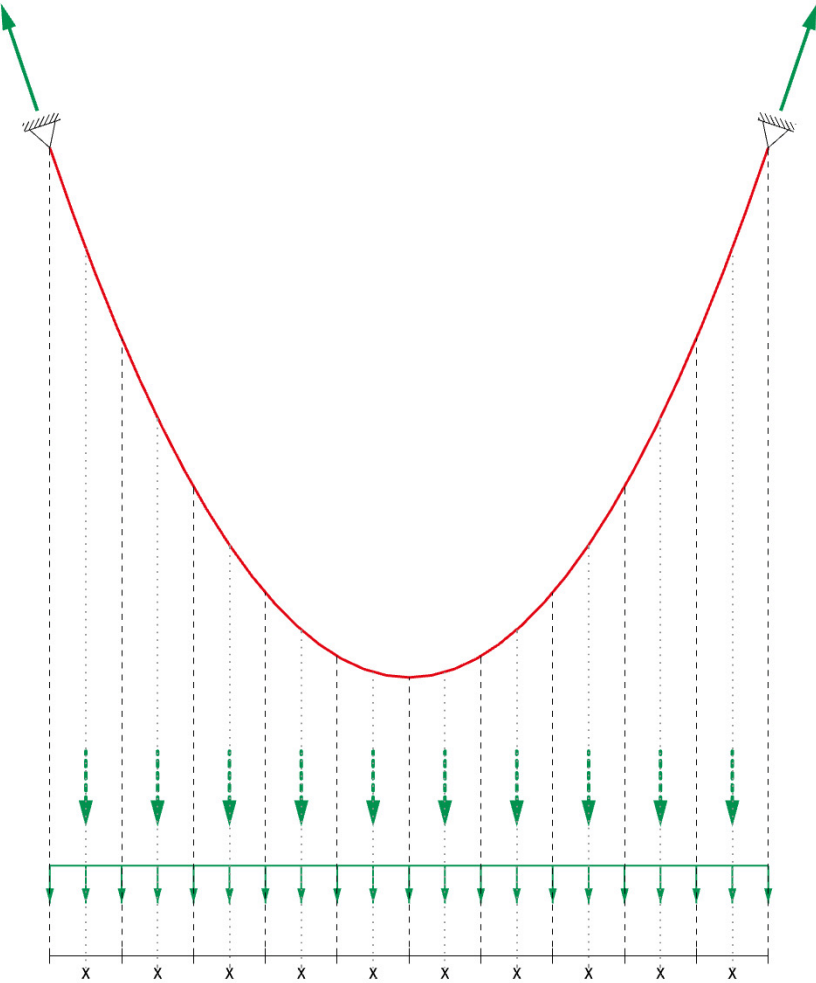

Parabel  
*Parabola*

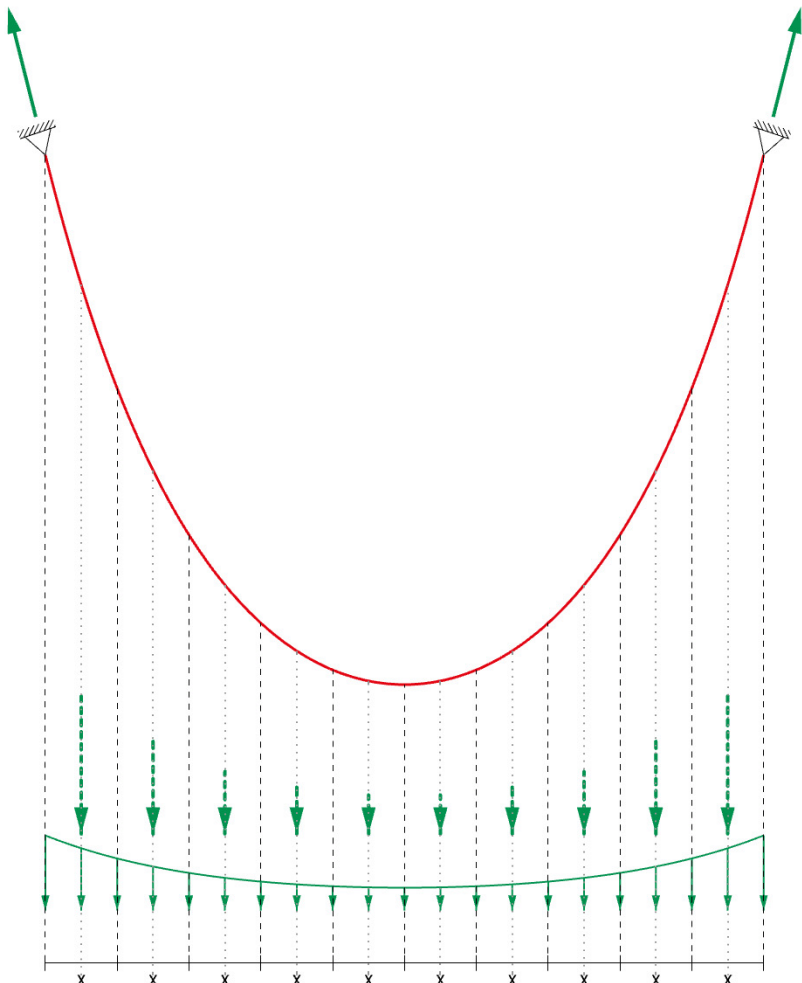
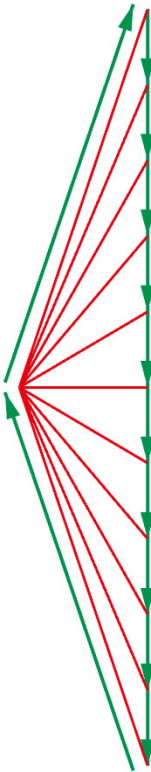

Kettenlinie  
*Catenary*

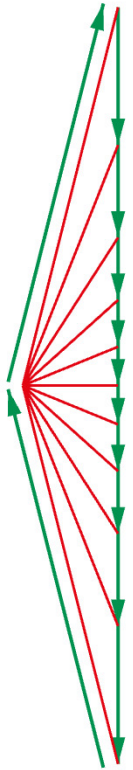

*A cable's reaction to uniformly distributed loads*

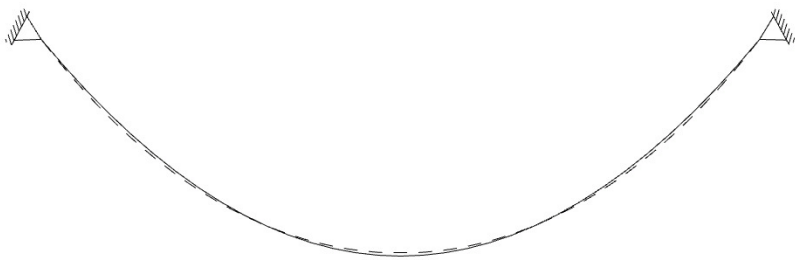
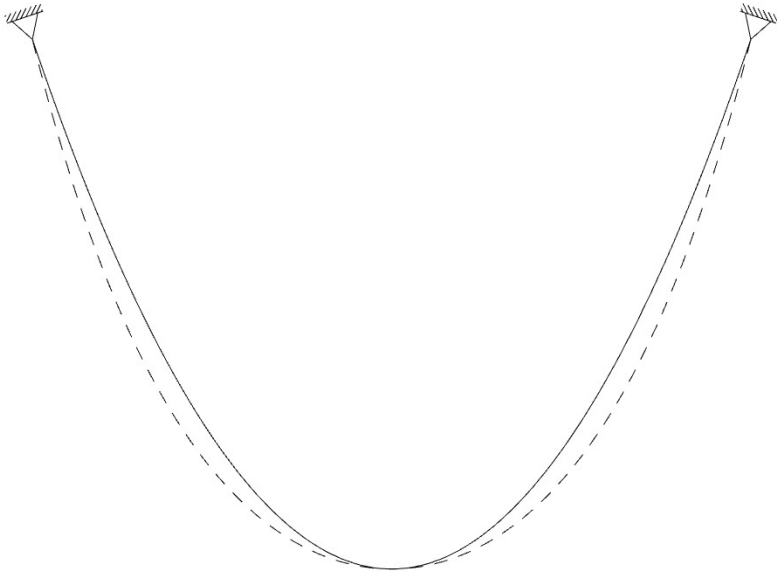
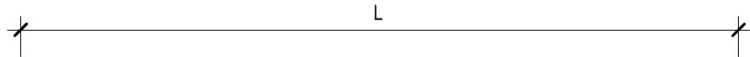

Annähernd gleiche Länge  
*Approximately same length*

eQ: Parabola vs. Catenary

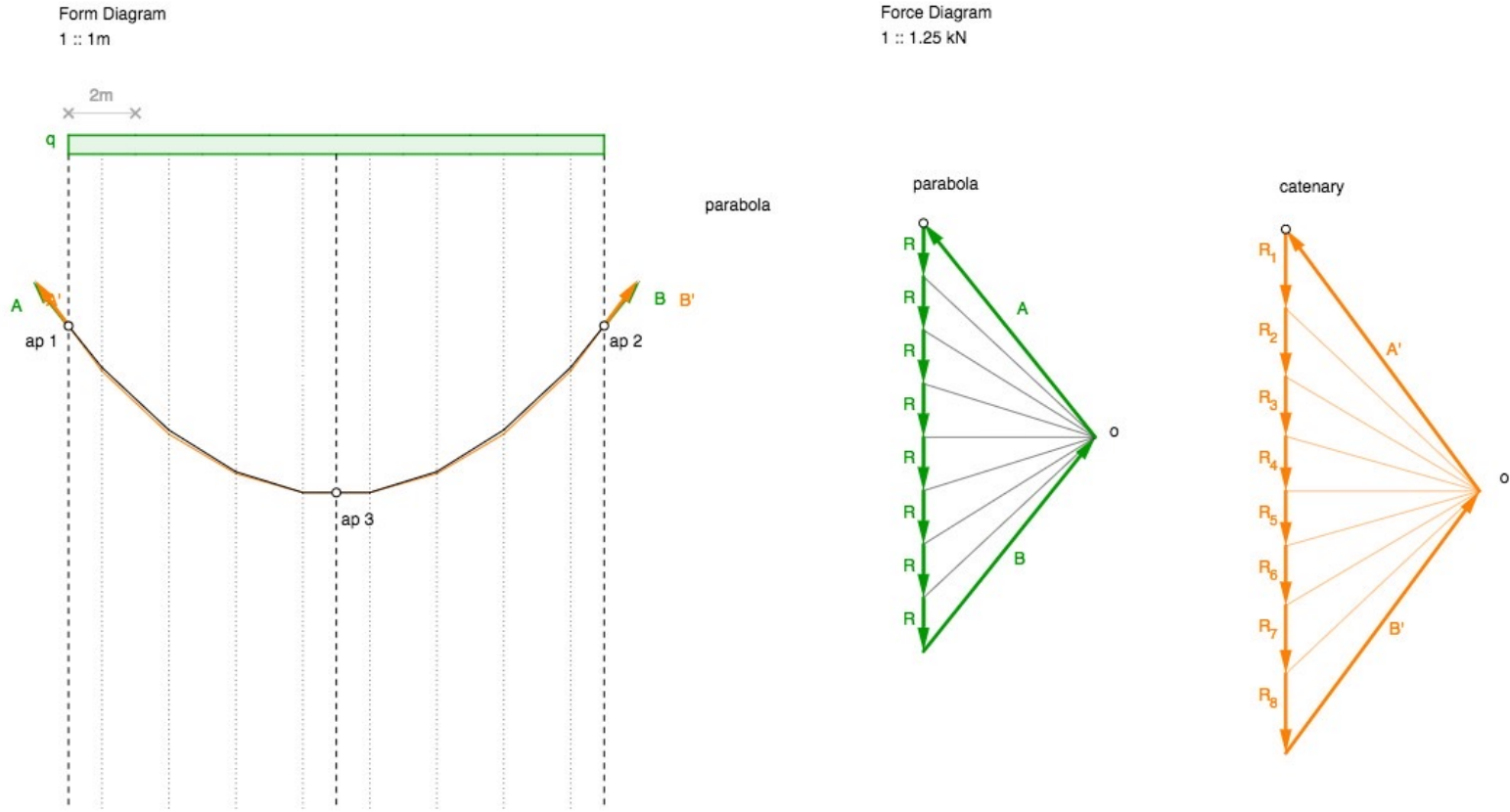

<http://www.block.arch.ethz.ch/eq/drawing/view/10>

# Seile

## *Cables*

Tragwirkung eines Seils unter mehreren beliebigen Lasten

*A cable's reaction to a set of non-concurrent loads*

Tragwirkung eines Seils unter gleichmässig verteilter Belastung

*A cable's reaction to uniformly distributed loads*

>>

Fallstudie: Golden Gate Brücke

*Case study: Golden Gate bridge*

Formänderung von Seiltragwerken

*Form-active behaviour of cables*

Aussteifung durch Erhöhung der Eigenlasten

*Stiffening by increasing dead loads*

Aussteifung durch Vorspannung

*Stiffening through prestressing*

Aussteifung mittels eines Fachwerks

*Stiffening using a truss*

Übersicht der Aussteifungssysteme

*Overview of stiffening schemes*



Joseph Strauss: Golden Gate Brücke, San Francisco, 1937



*Case study: Golden Gate Bridge*

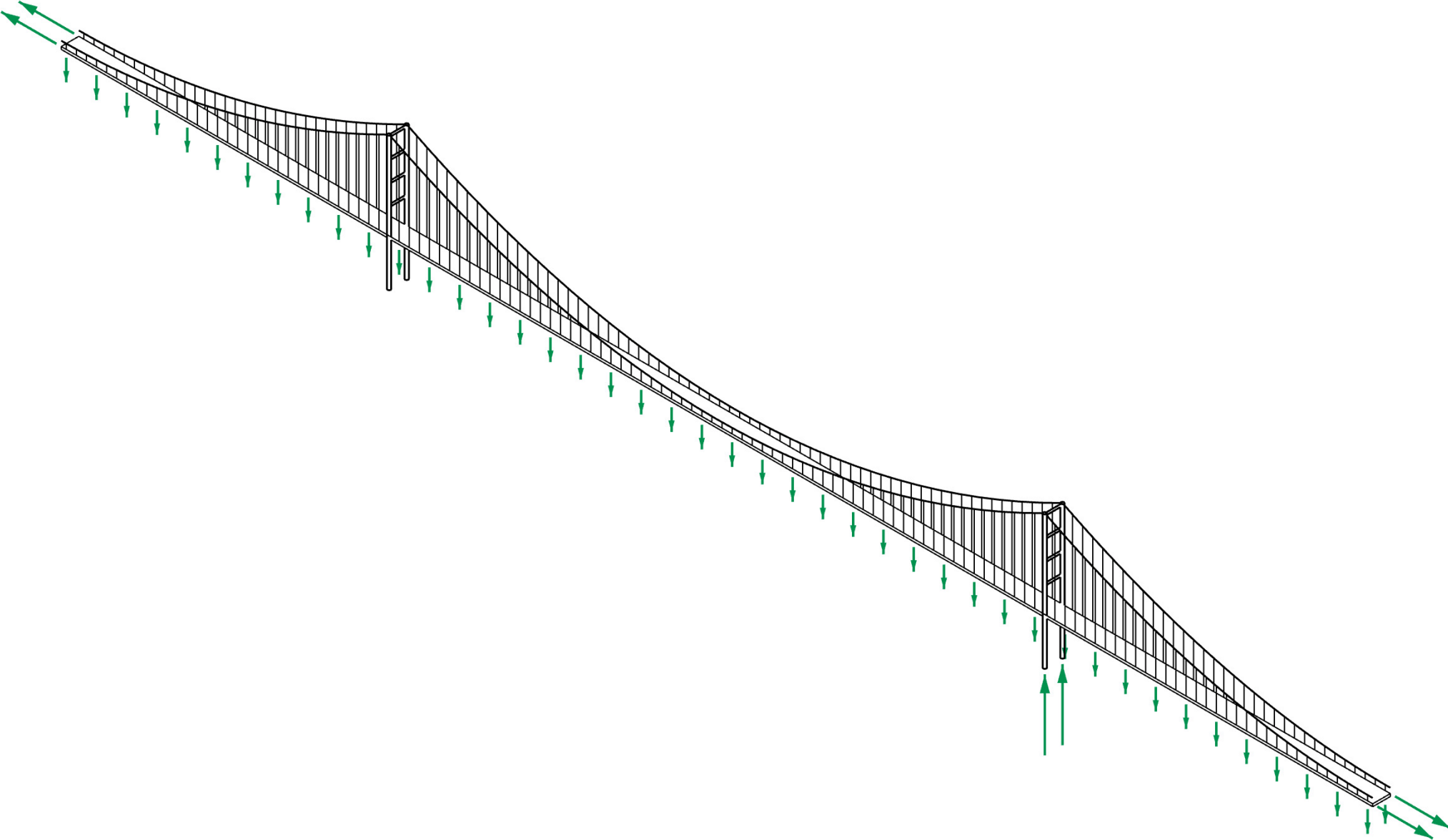

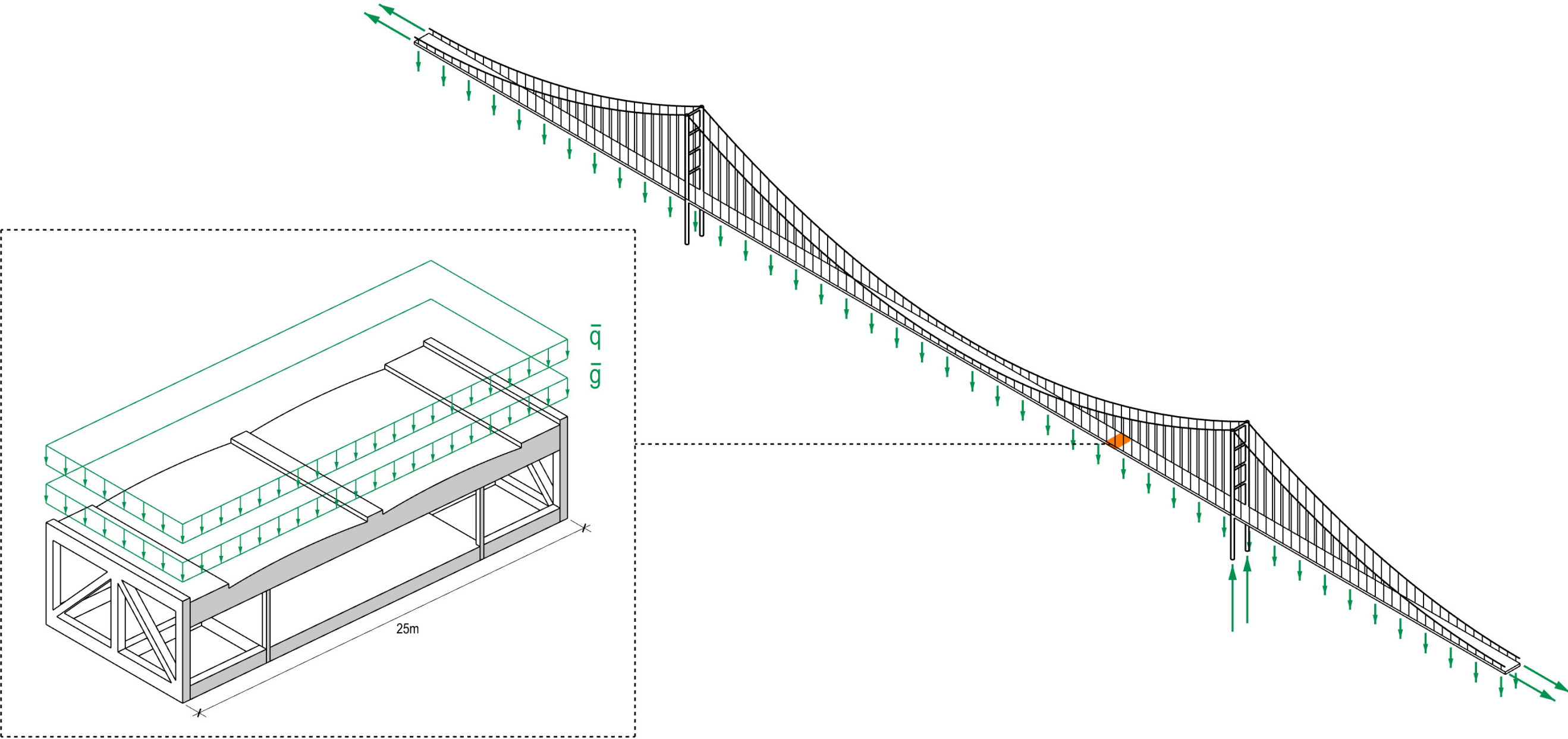



*A cable's reaction to uniformly distributed loads*

$\bar{q}$  (kN/m<sup>2</sup>)

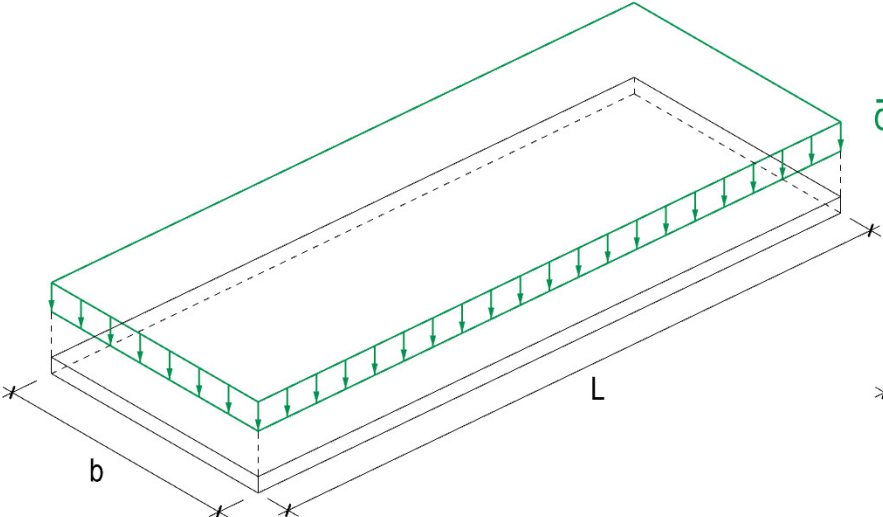

$q = \bar{q} * b$  (kN/m)

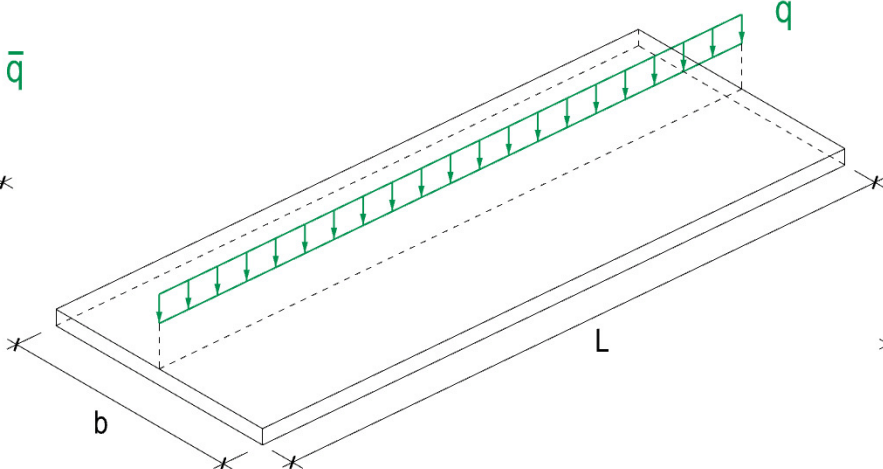

$Q = q * L$  (kN)

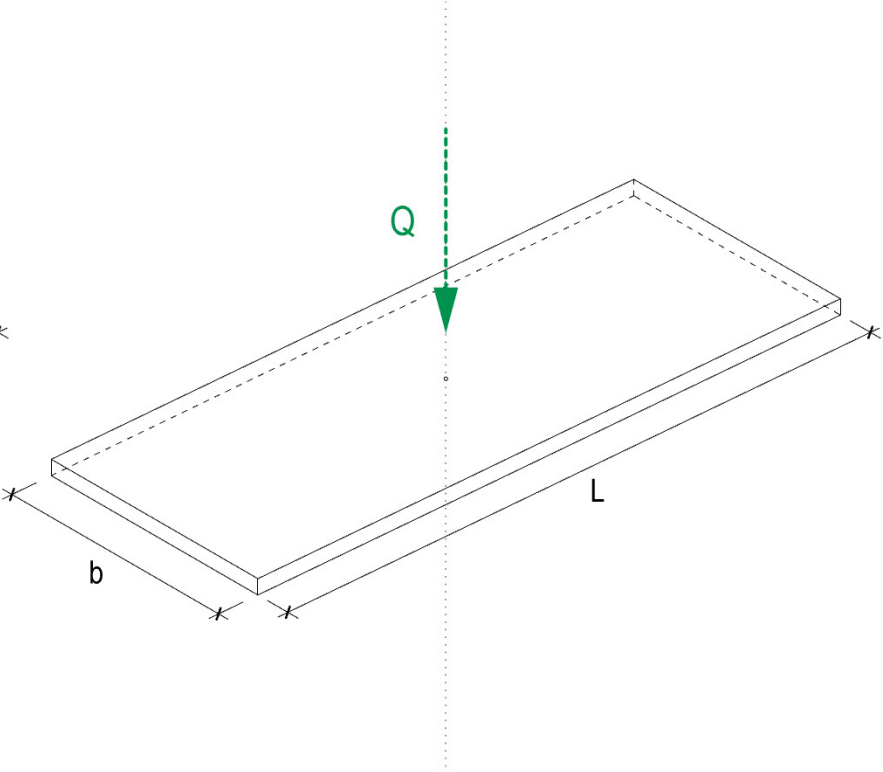

*A cable's reaction to uniformly distributed loads*

$\bar{q}$  (kN/m<sup>2</sup>)

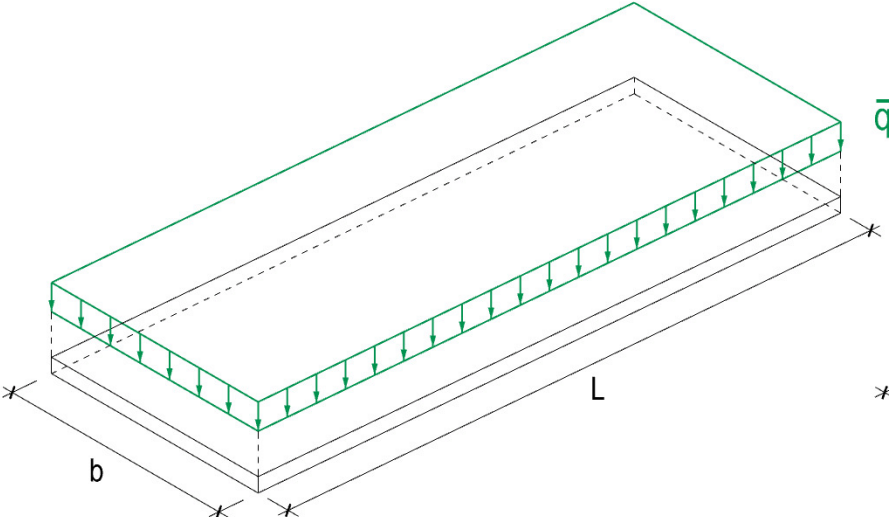

$q = \bar{q} * b$  (kN/m)

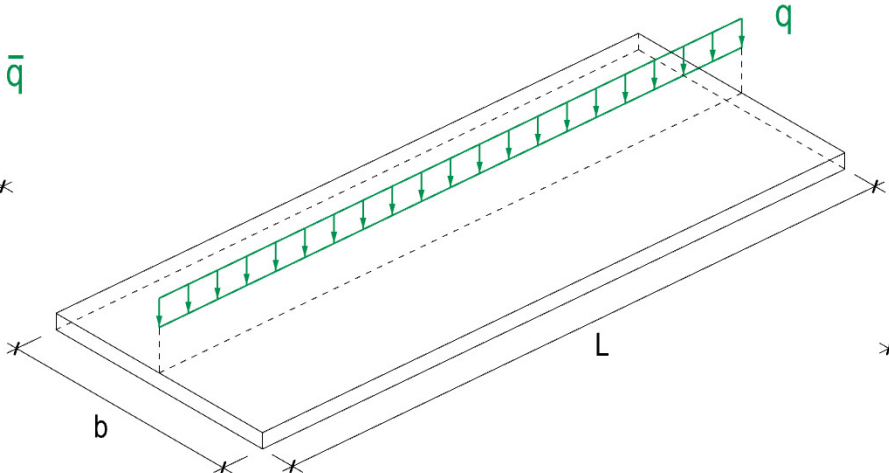

$Q = q * L$  (kN)

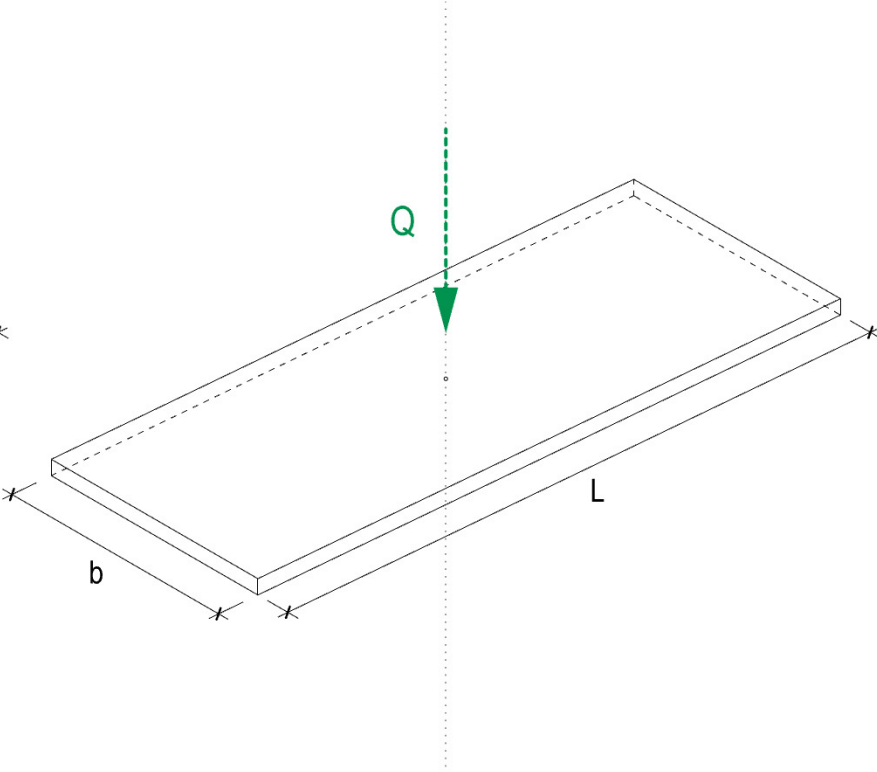

Beispiel:

*Example:*

$b = 3 \text{ m}$

$L = 10 \text{ m}$

$\bar{q} = 5 \text{ kN/m}^2$

$q = 5 \text{ kN/m}^2 * 3 \text{ m} = 15 \text{ kN/m}$

$Q = 15 \text{ kN/m} * 10 \text{ m} = 150 \text{ kN}$

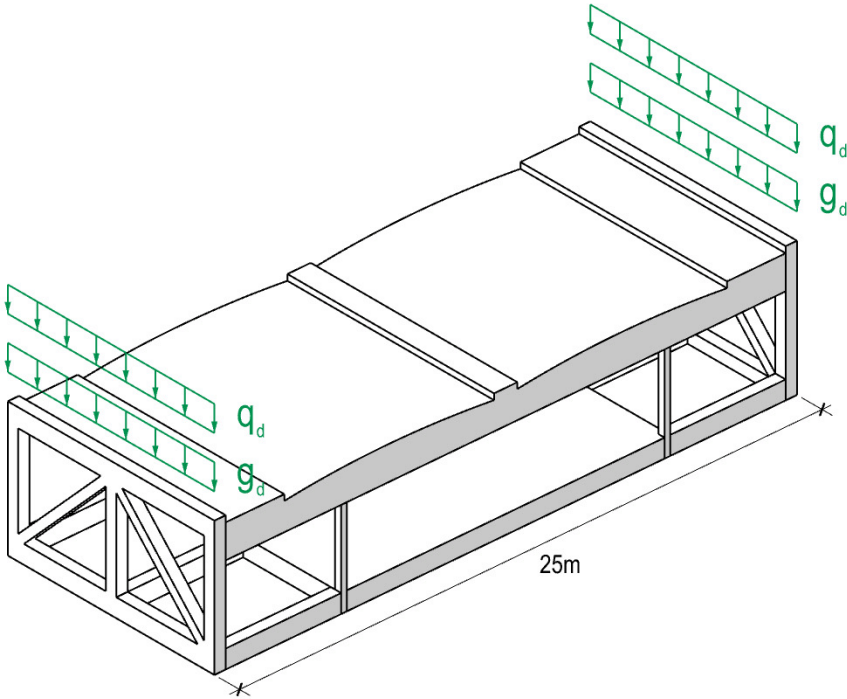
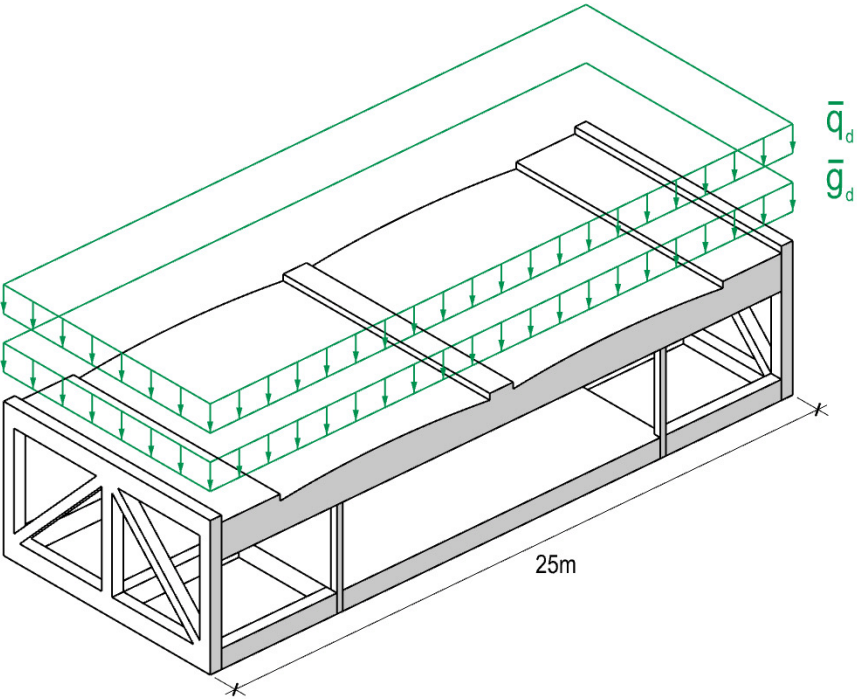

Dead load

$$\bar{g}_d = 60 \text{ kN/m}^2$$

$$g_d = 60 \text{ kN/m}^2 * 25 \text{ m} / 2 = 750 \text{ kN/m}$$

Live load

$$\bar{q}_{use} = 9 \text{ kN/m}^2$$

$$\bar{q}_{snow} = 1.5 \text{ kN/m}^2$$

$$\bar{q}_d = (9 \text{ kN/m}^2 + 1.5 \text{ kN/m}^2) * 1.5 = 15.75 \text{ kN/m}^2$$

$$q_d = 15.75 \text{ kN/m}^2 * 25 \text{ m} / 2 = 200 \text{ kN/m}$$

$g_d + q_d = 750 \text{ kN/m} + 200 \text{ kN/m} = 950 \text{ kN/m}$
--

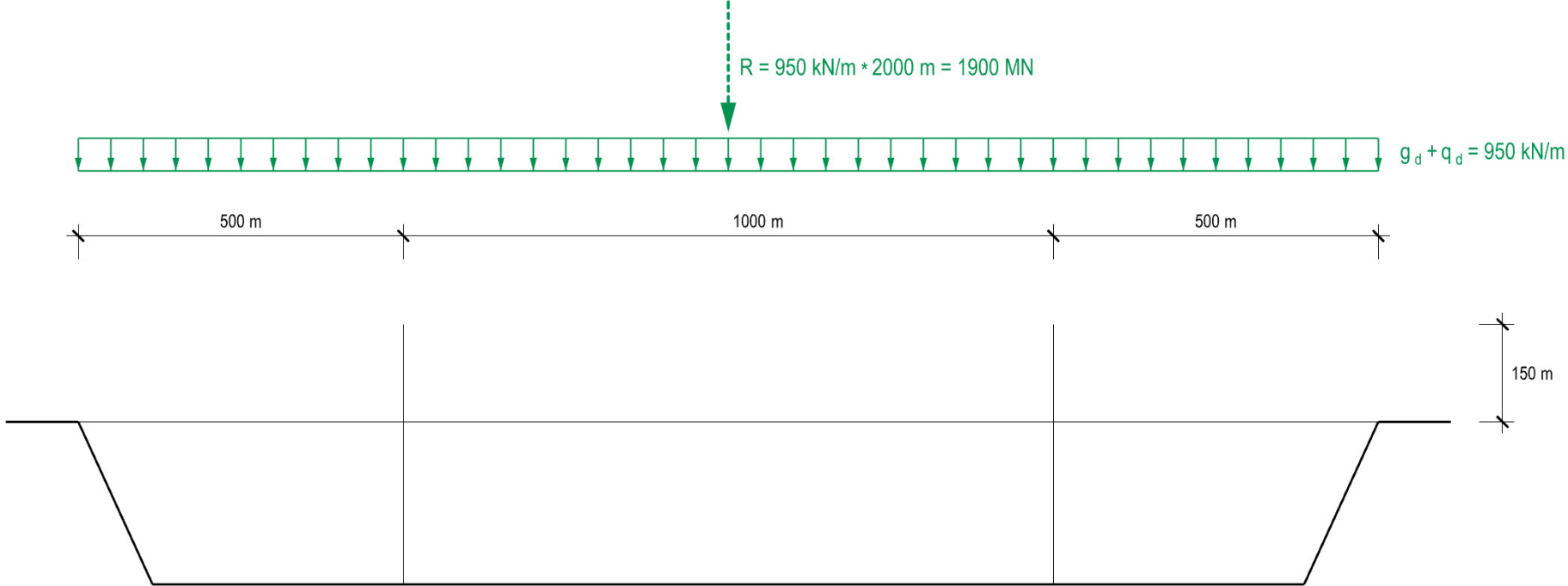

Case study: Golden Gate Bridge

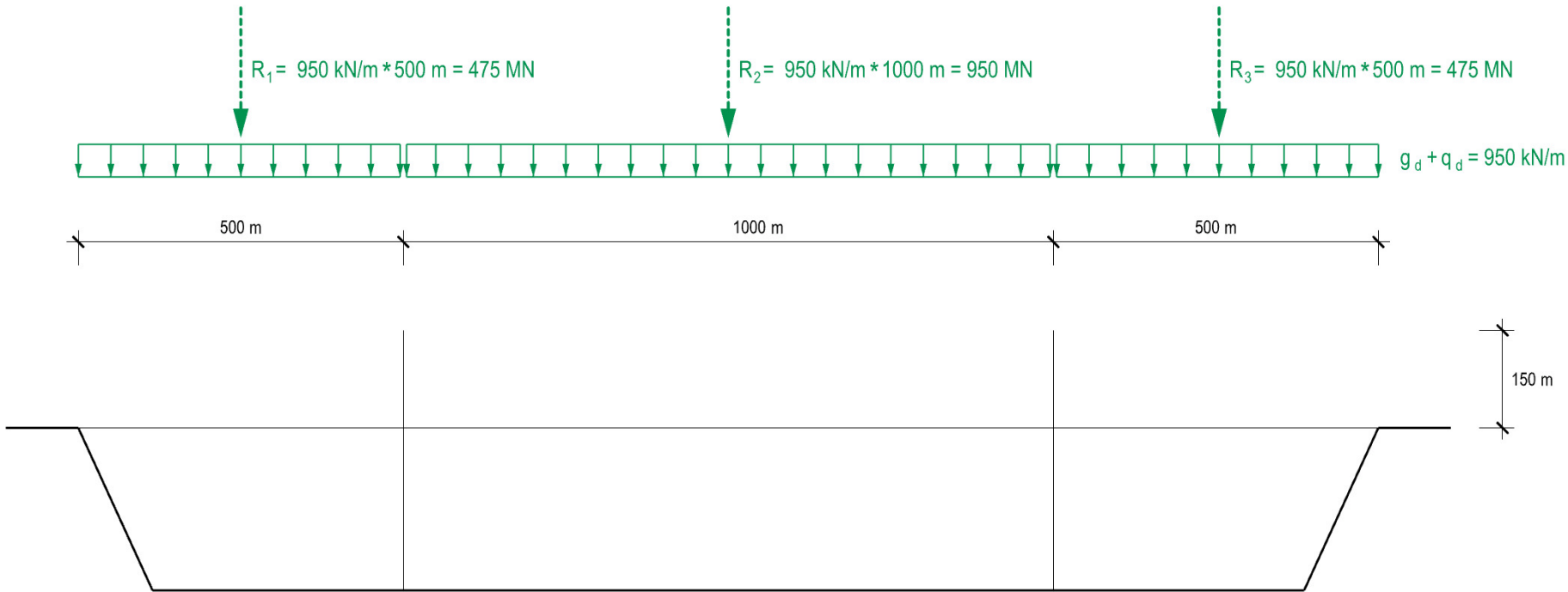

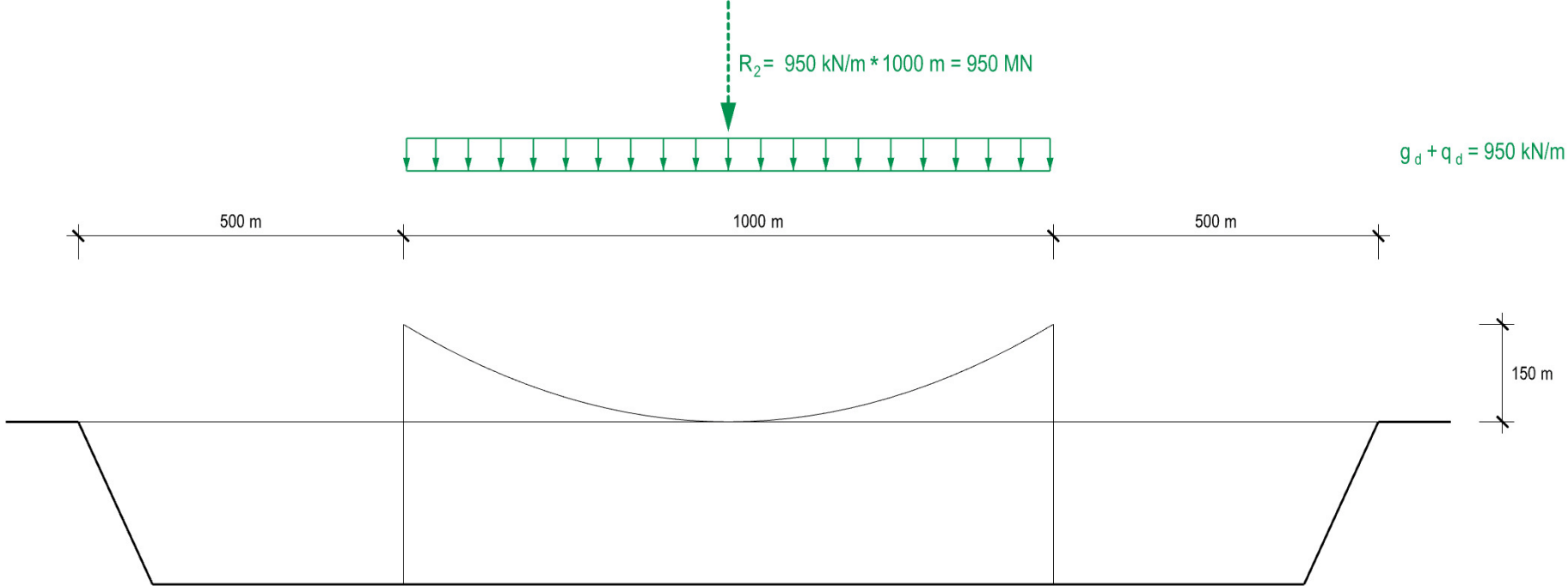

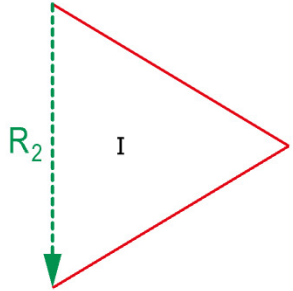
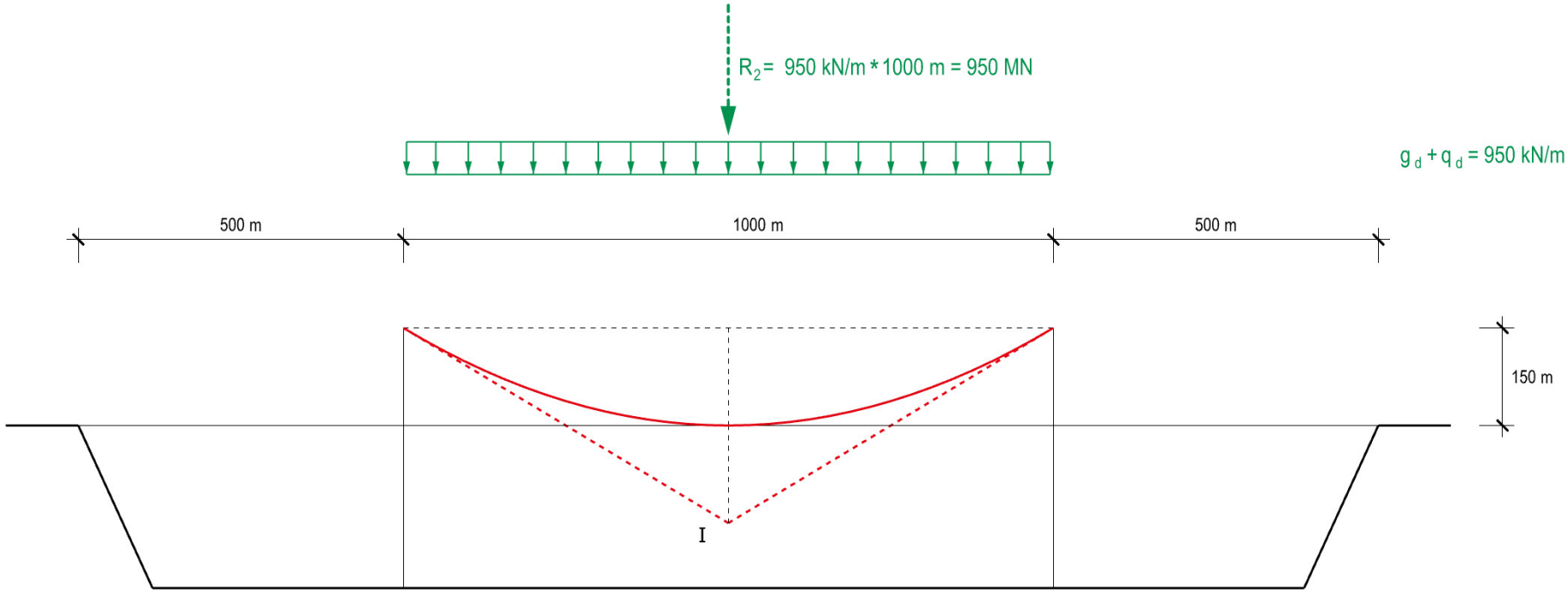



Case study: Golden Gate Bridge

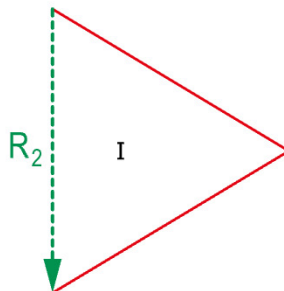
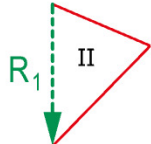
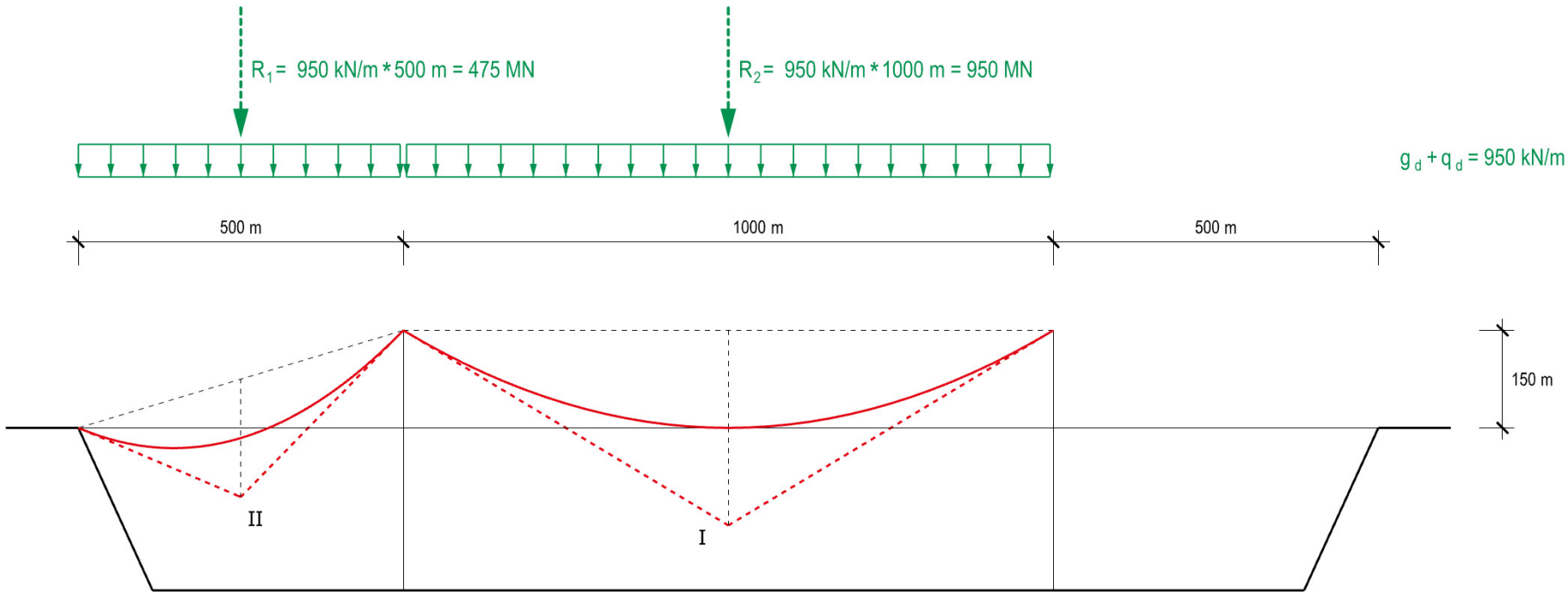

Case study: Golden Gate Bridge

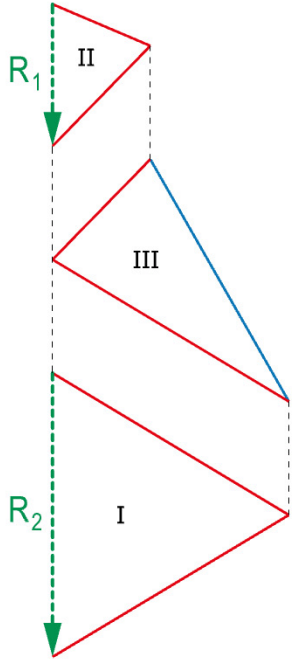
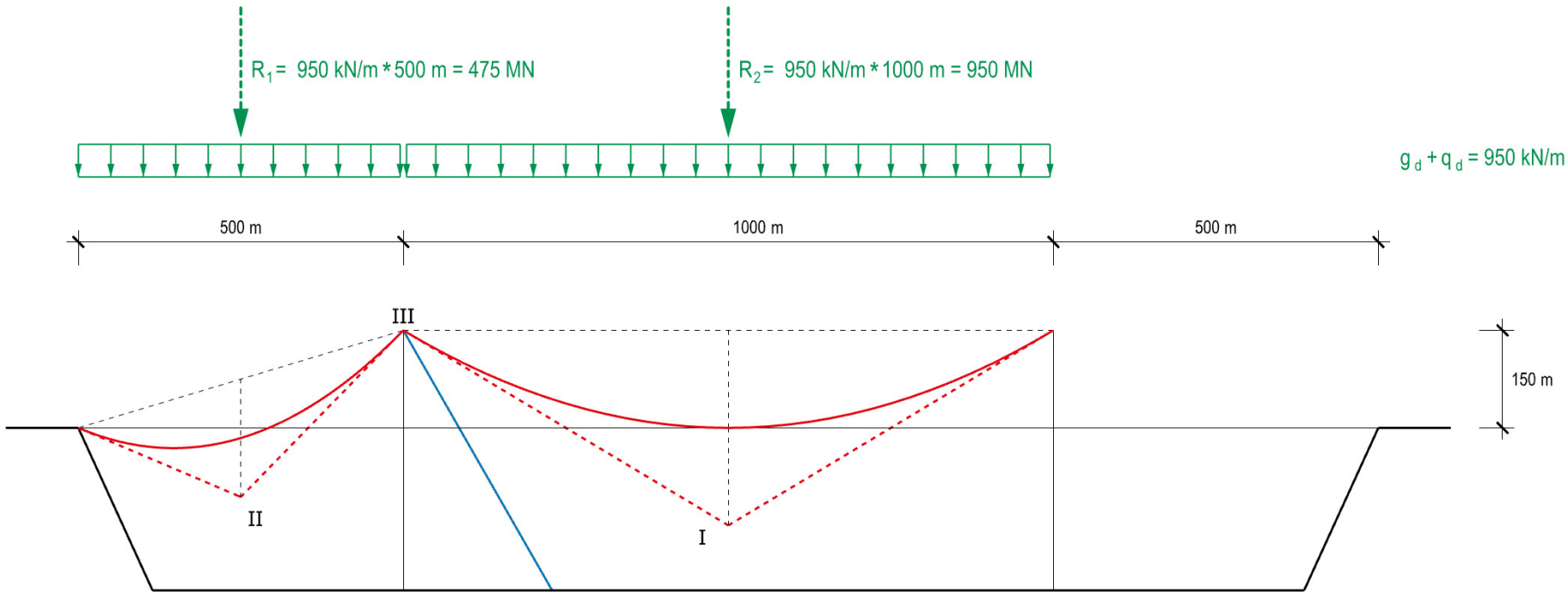

Case study: Golden Gate Bridge

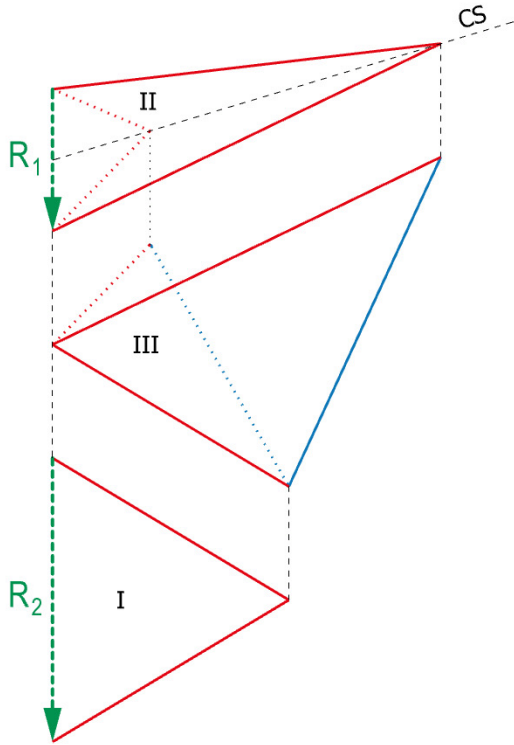
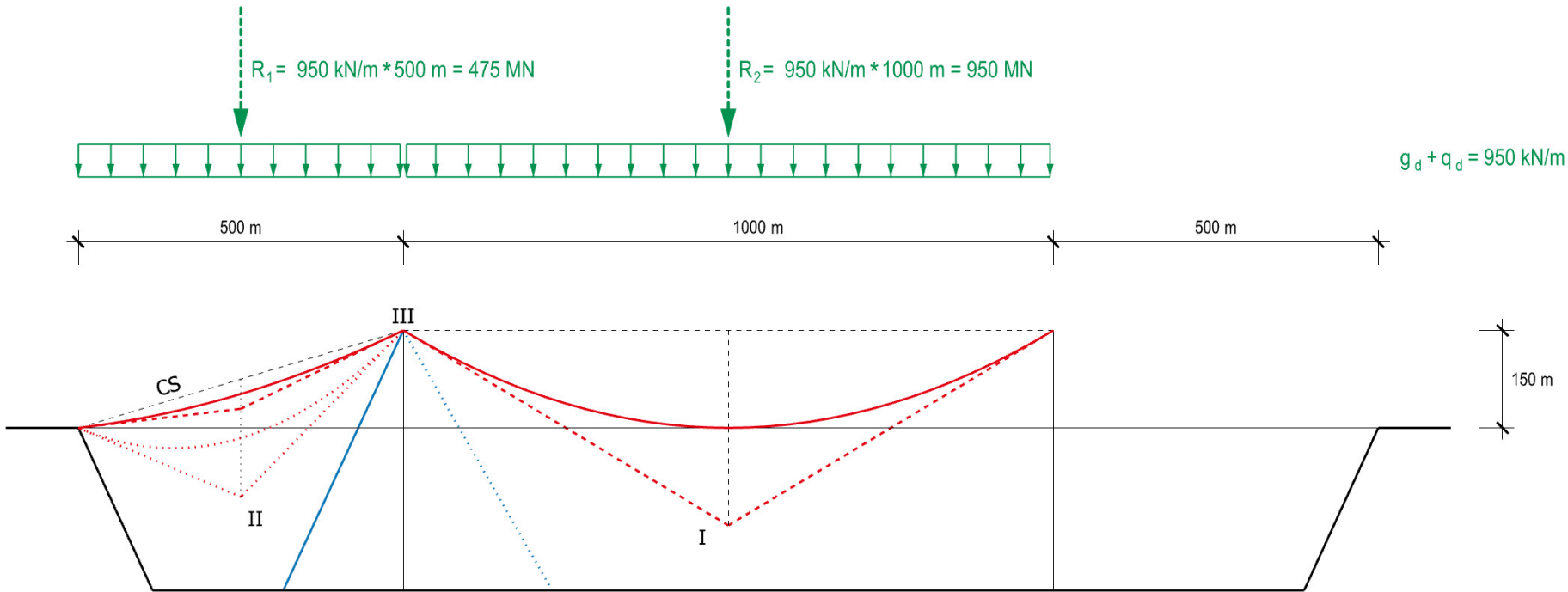

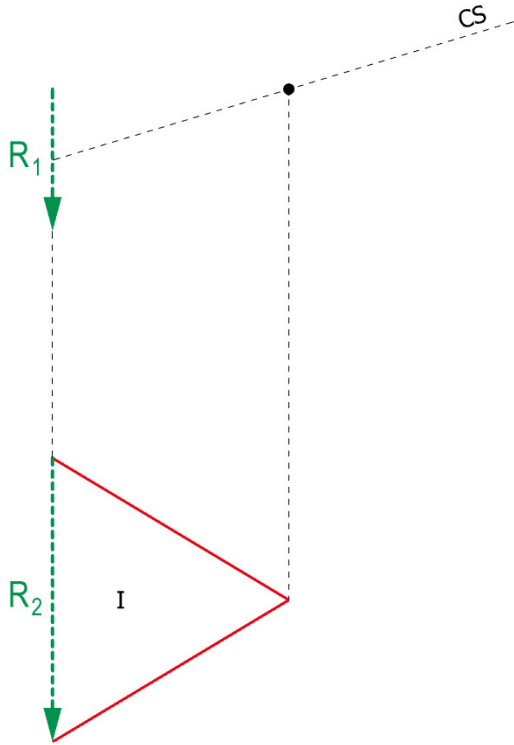
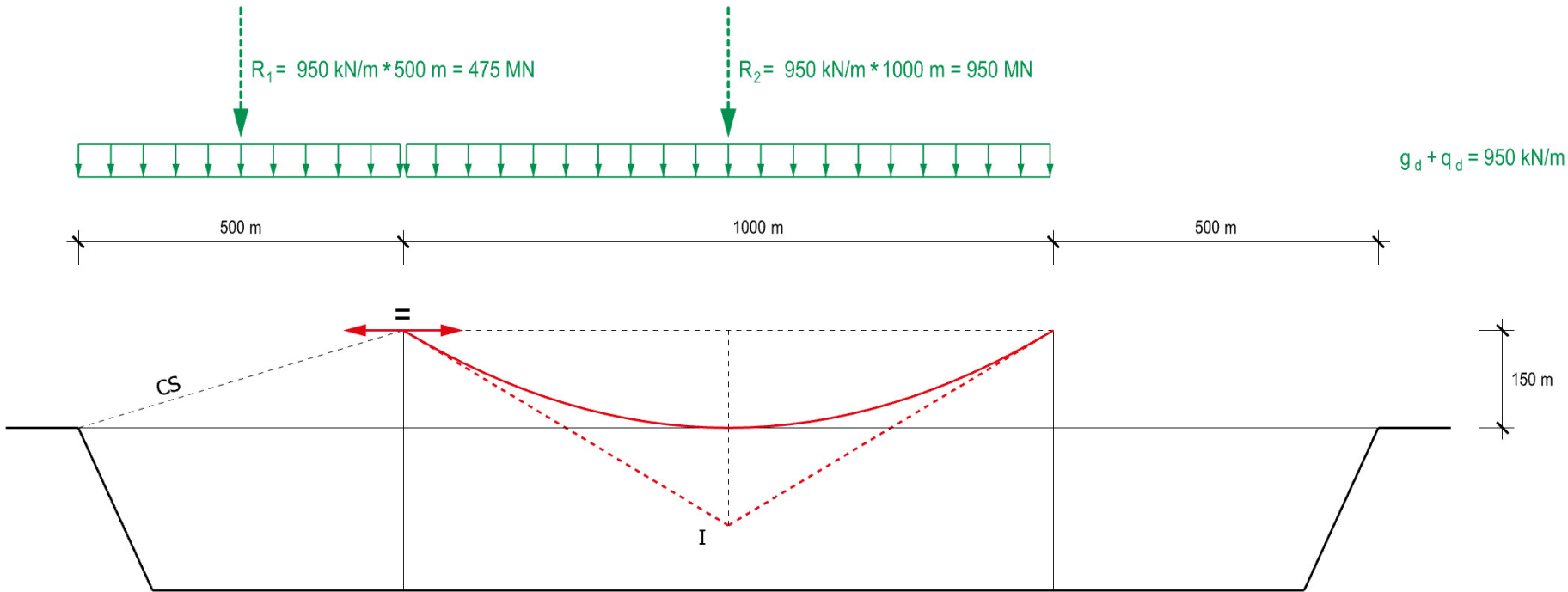

Case study: Golden Gate Bridge

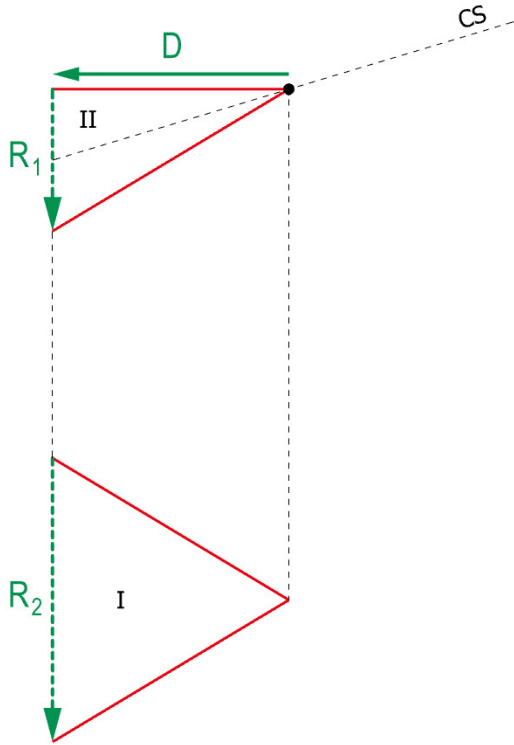
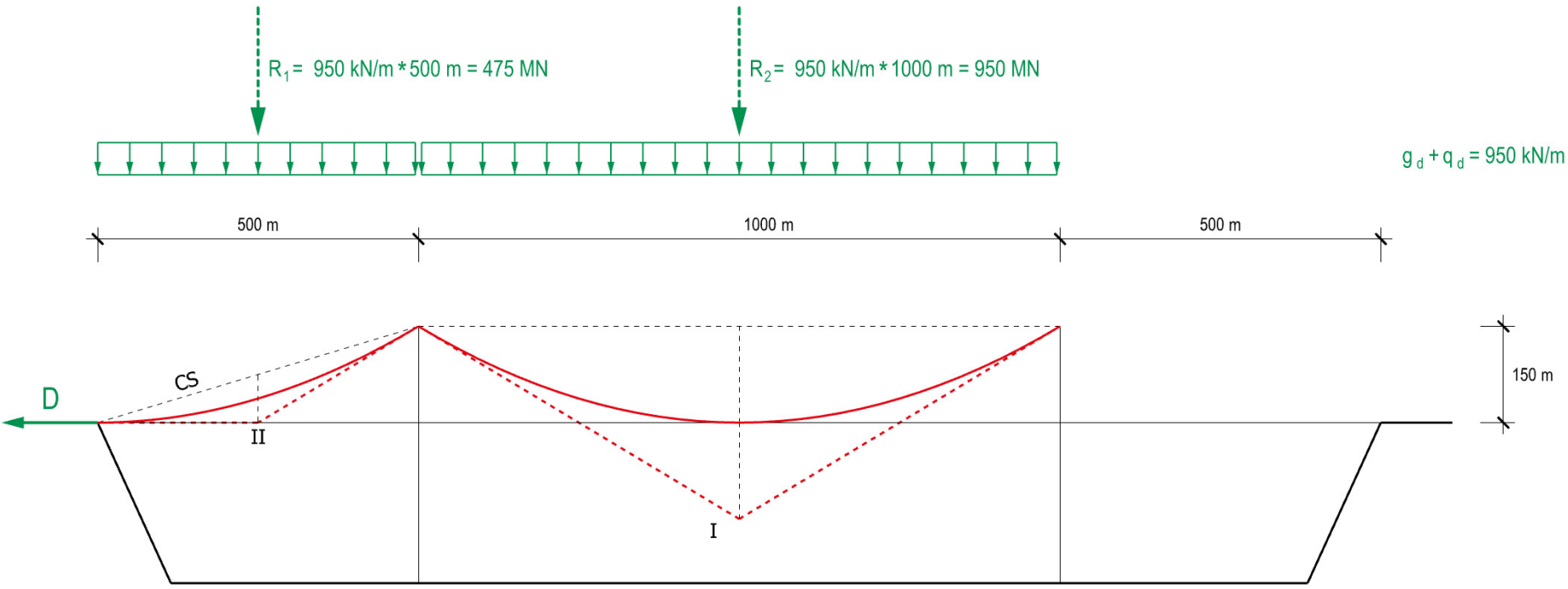

Case study: Golden Gate Bridge

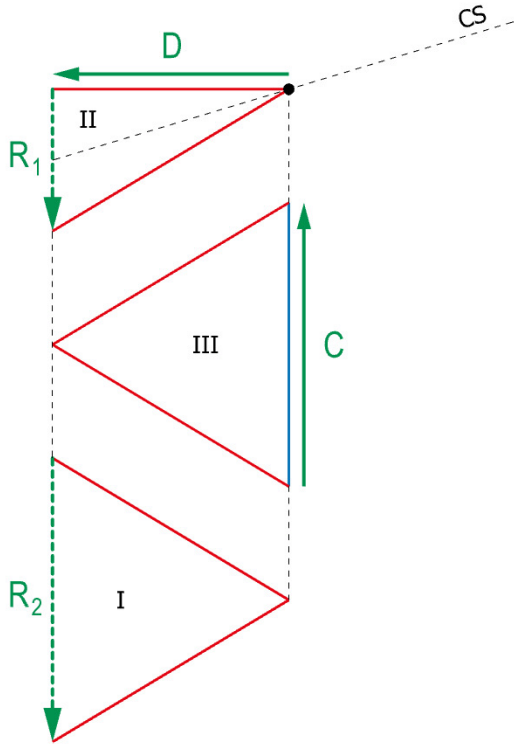
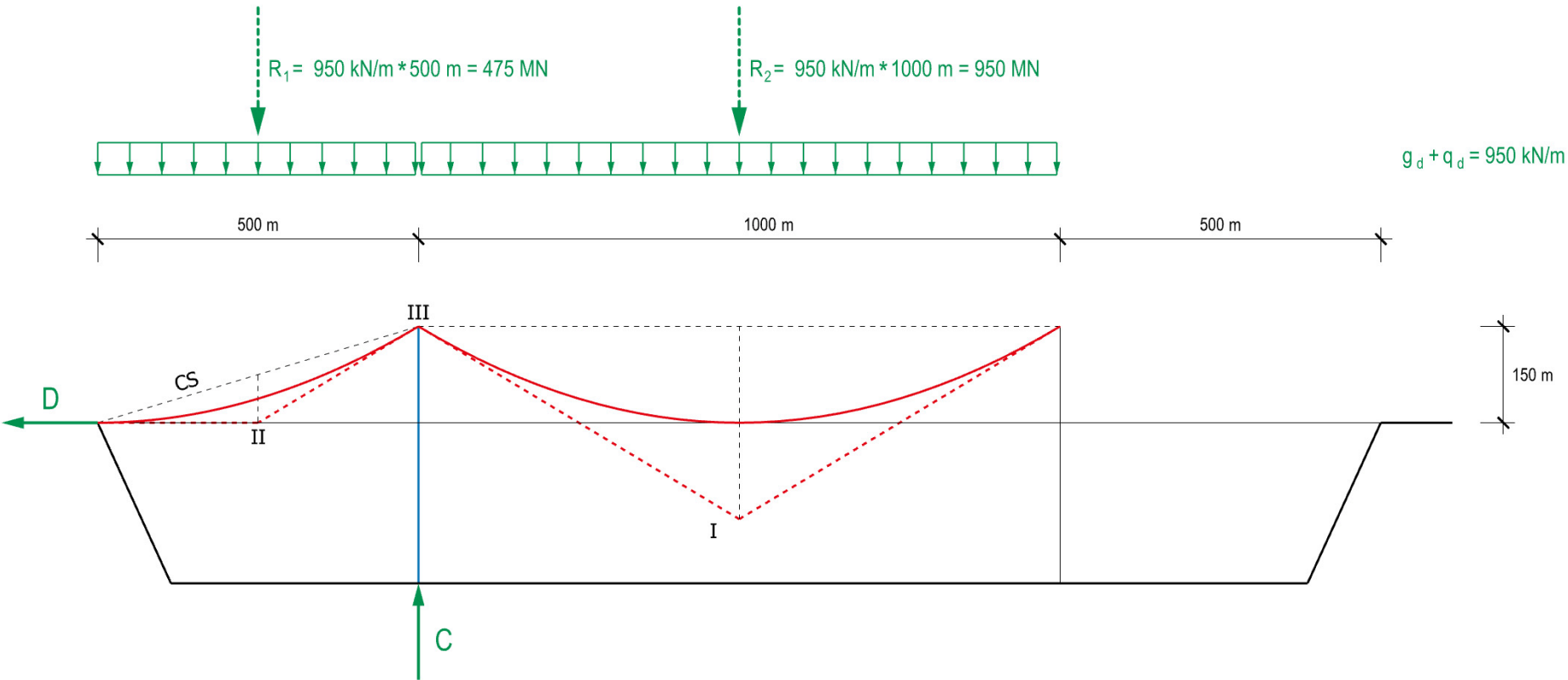

Case study: Golden Gate Bridge

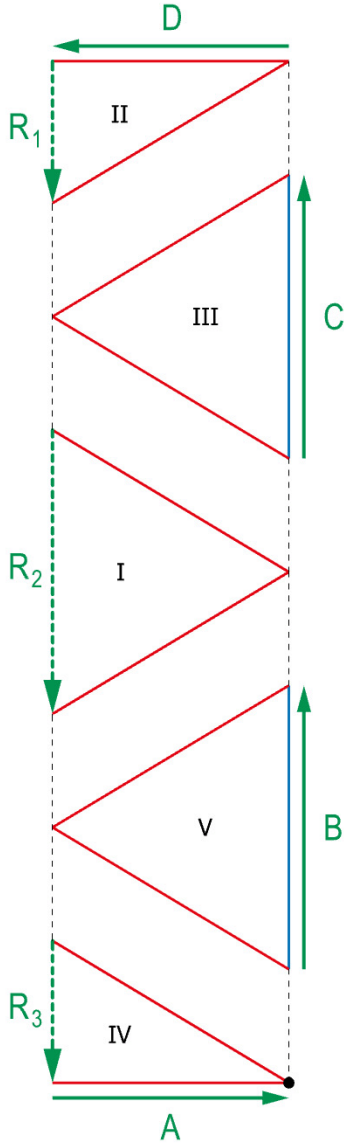
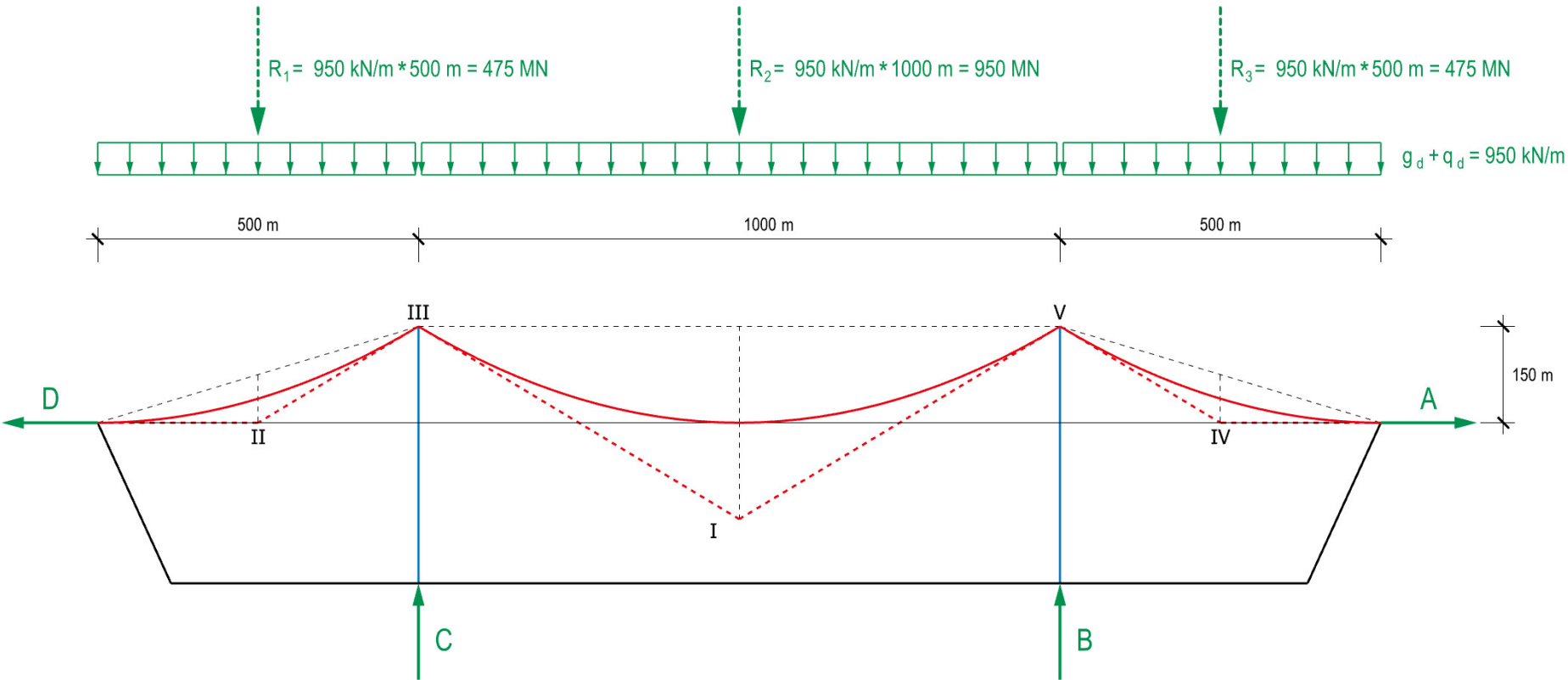



Case study: Golden Gate Bridge

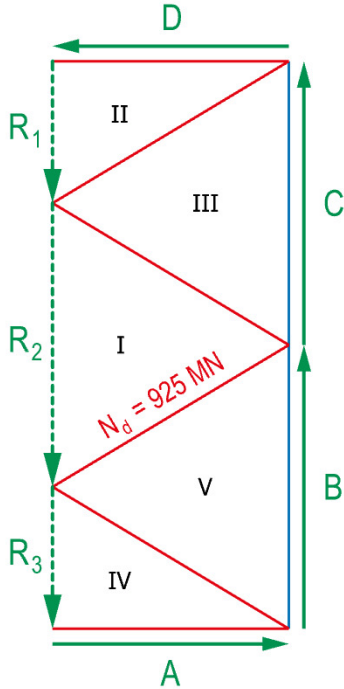
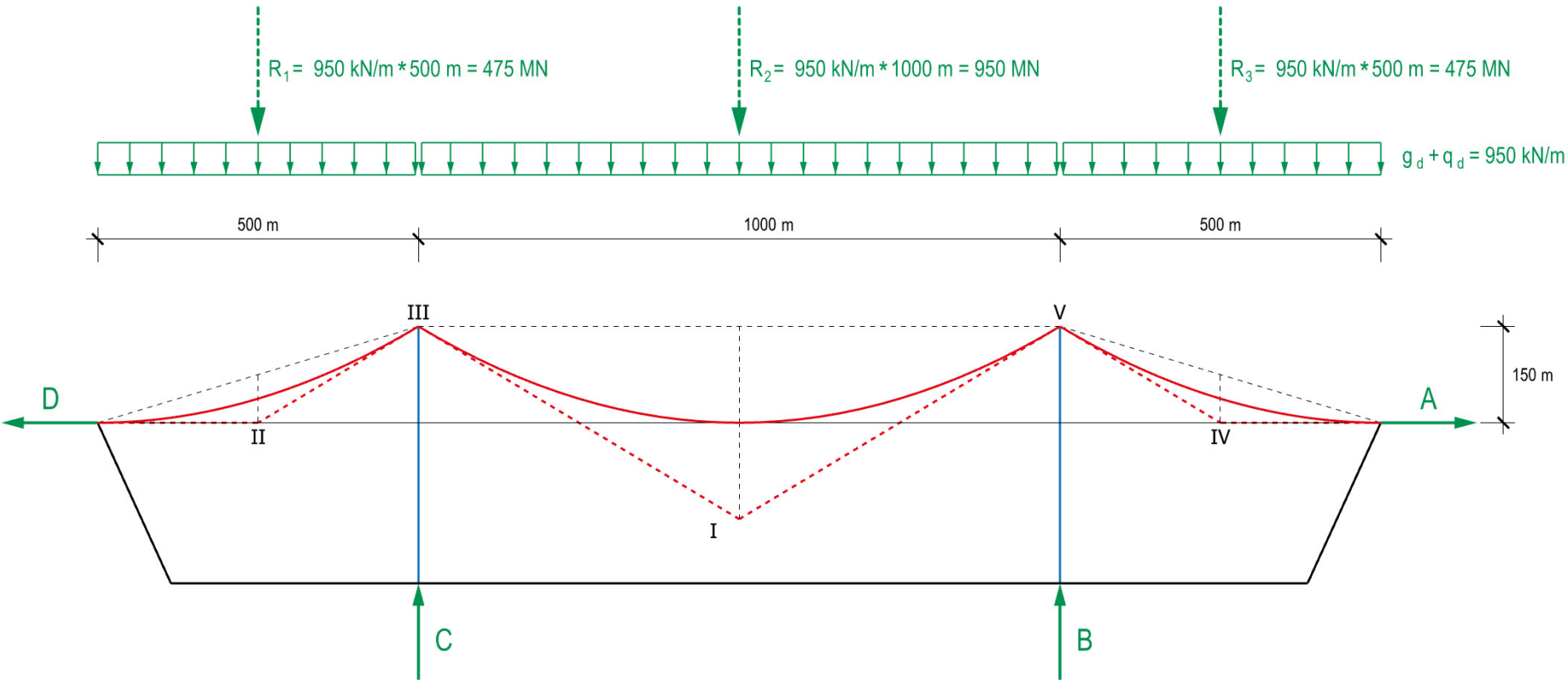

$$f_{s,d}^+ = 1410 \text{ N/mm}^2 / 1.05 = 1343 \text{ N/mm}^2 = 0.00134 \text{ MN/mm}^2$$

$$A_{\text{req}} \geq \frac{N_d}{f_{s,d}^+} = \frac{925 \text{ MN}}{0.00134 \text{ MN/mm}^2} = 690'300 \text{ mm}^2$$

$$A = \pi \cdot r^2; \quad r \geq 469 \text{ mm}; \quad \varnothing \geq 93.8 \text{ cm}$$

Case study: Golden Gate Bridge

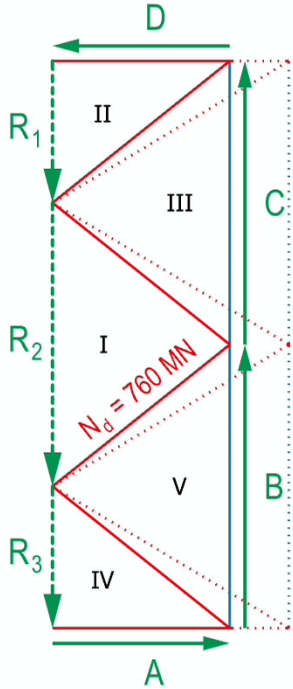
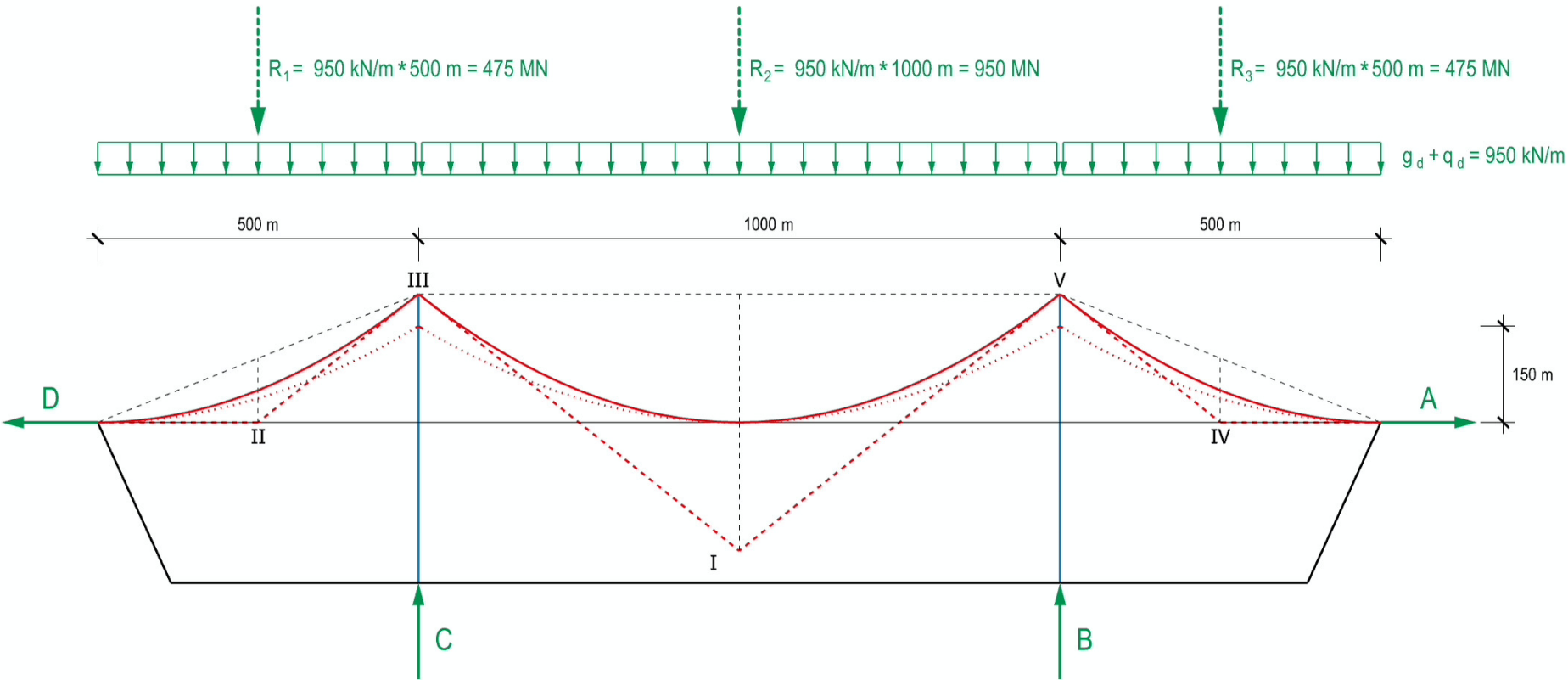

$$f_{s,d}^+ = 1410 \text{ N/mm}^2 / 1.05 = 1343 \text{ N/mm}^2 = 0.00134 \text{ MN/mm}^2$$

$$A_{\text{req}} \geq \frac{N_d}{f_{s,d}^+} = \frac{760 \text{ MN}}{0.00134 \text{ MN/mm}^2} = 567'200 \text{ mm}^2$$

$$A = \pi \cdot r^2; \quad r \geq 425 \text{ mm}; \quad \varnothing \geq 85 \text{ cm}$$





Mockup eines Kabels der Golden Gate Brücke



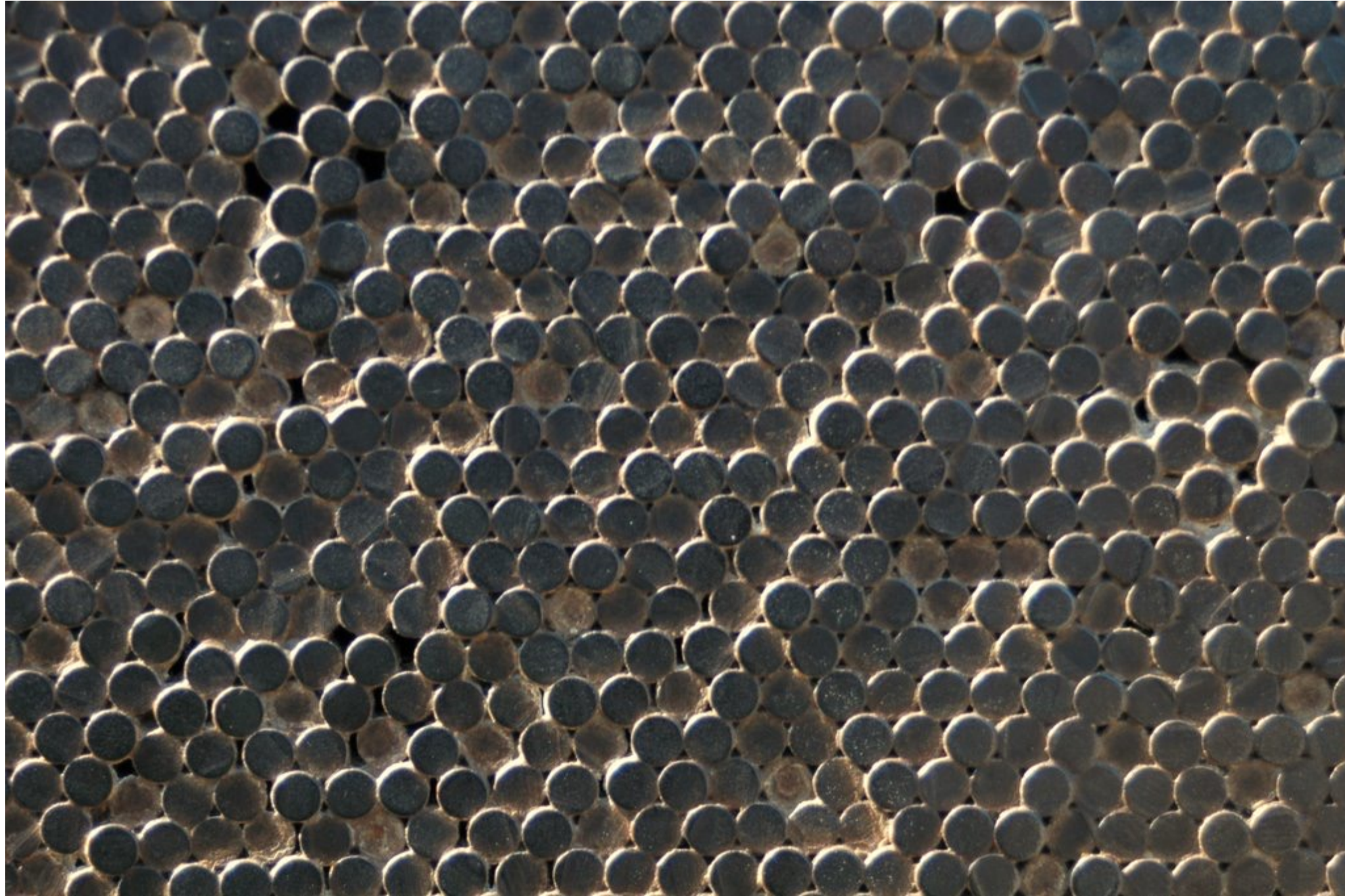

Mockup eines Kabels der Golden Gate Brücke



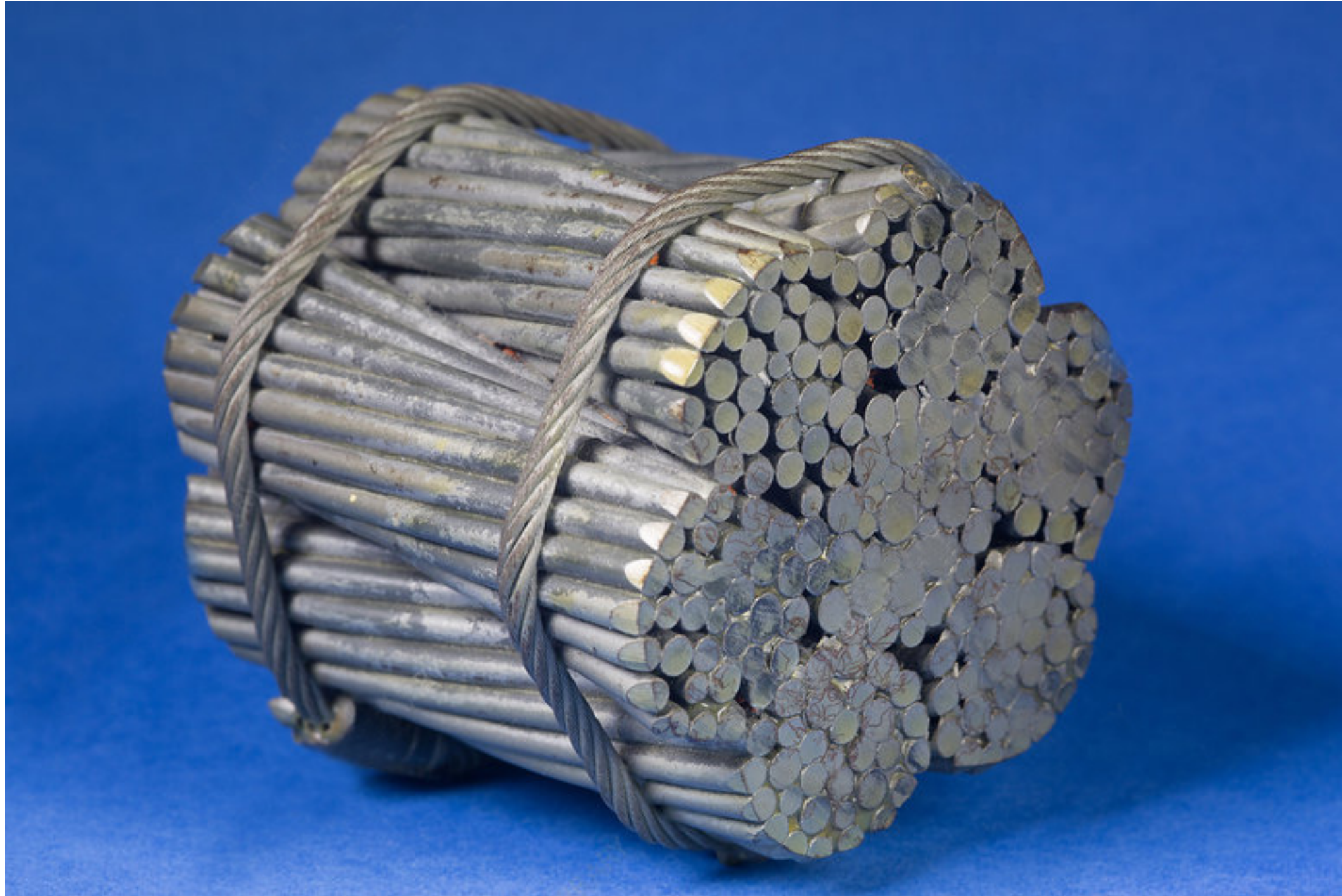

Detail eines Kabelstrangs





P.L. Nervi: Papierfabrik Burgo, Manuta, Italien, 1962



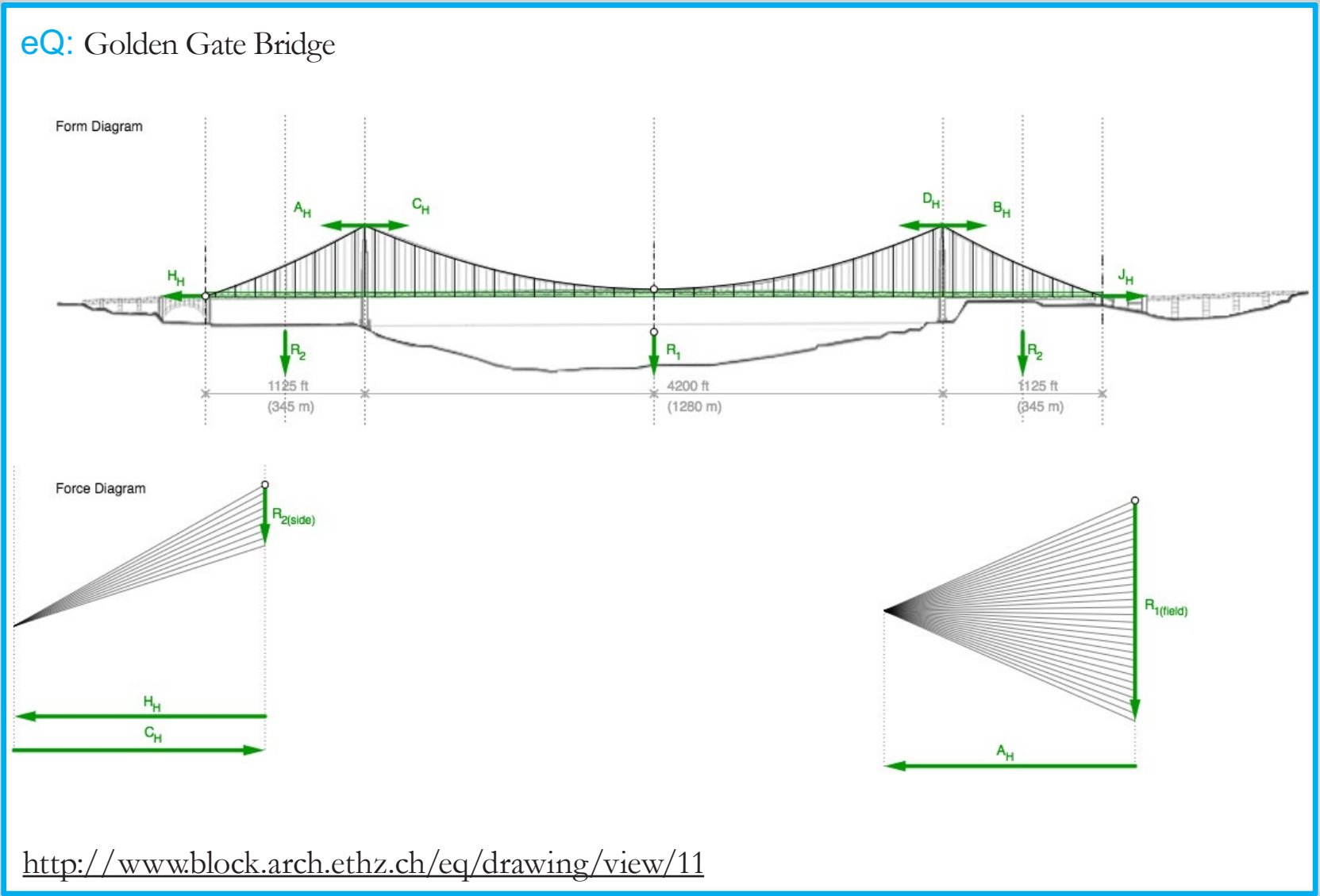



# Seile

## *Cables*

Tragwirkung eines Seils unter mehreren beliebigen Lasten

*A cable's reaction to a set of non-concurrent loads*

Tragwirkung eines Seils unter gleichmässig verteilter Belastung

*A cable's reaction to uniformly distributed loads*

Fallstudie: Golden Gate Brücke

*Case study: Golden Gate bridge*

>>

Formänderung von Seiltragwerken

*Form-active behaviour of cables*

Aussteifung durch Erhöhung der Eigenlasten

*Stiffening by increasing dead loads*

Aussteifung durch Vorspannung

*Stiffening through prestressing*

Aussteifung mittels eines Fachwerks

*Stiffening using a truss*

Übersicht der Aussteifungssysteme

*Overview of stiffening schemes*



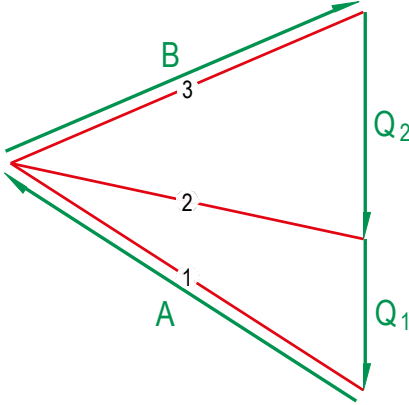
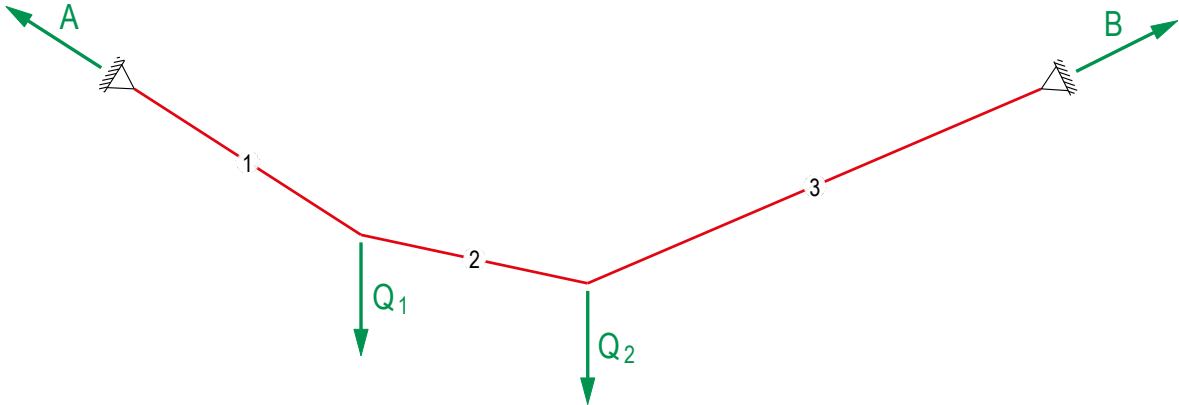
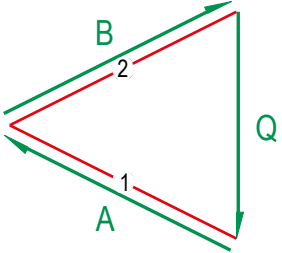
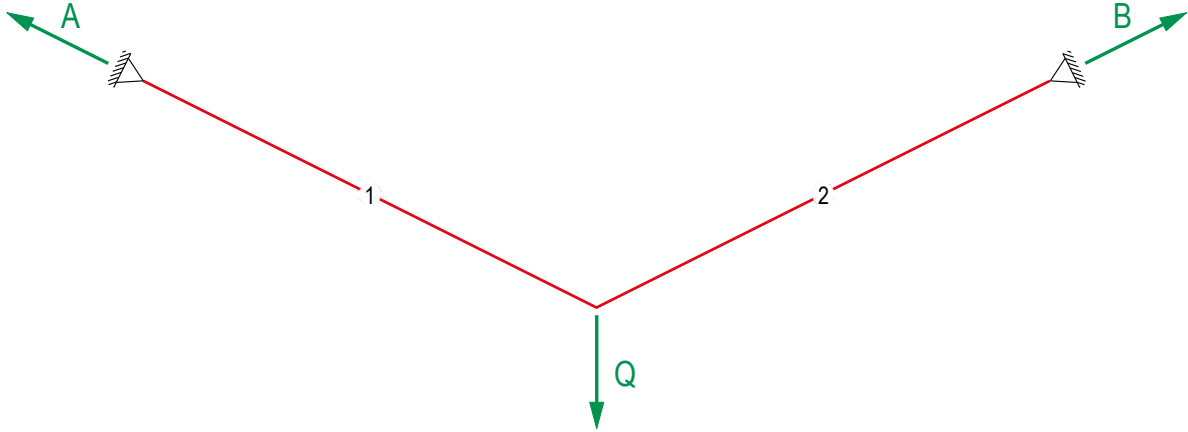

Lageplan 1:100  
*Form diagram 1:100*

Kräfteplan 1 cm  $\cong$  1 kN  
*Force diagram 1 cm  $\cong$  1 kN*

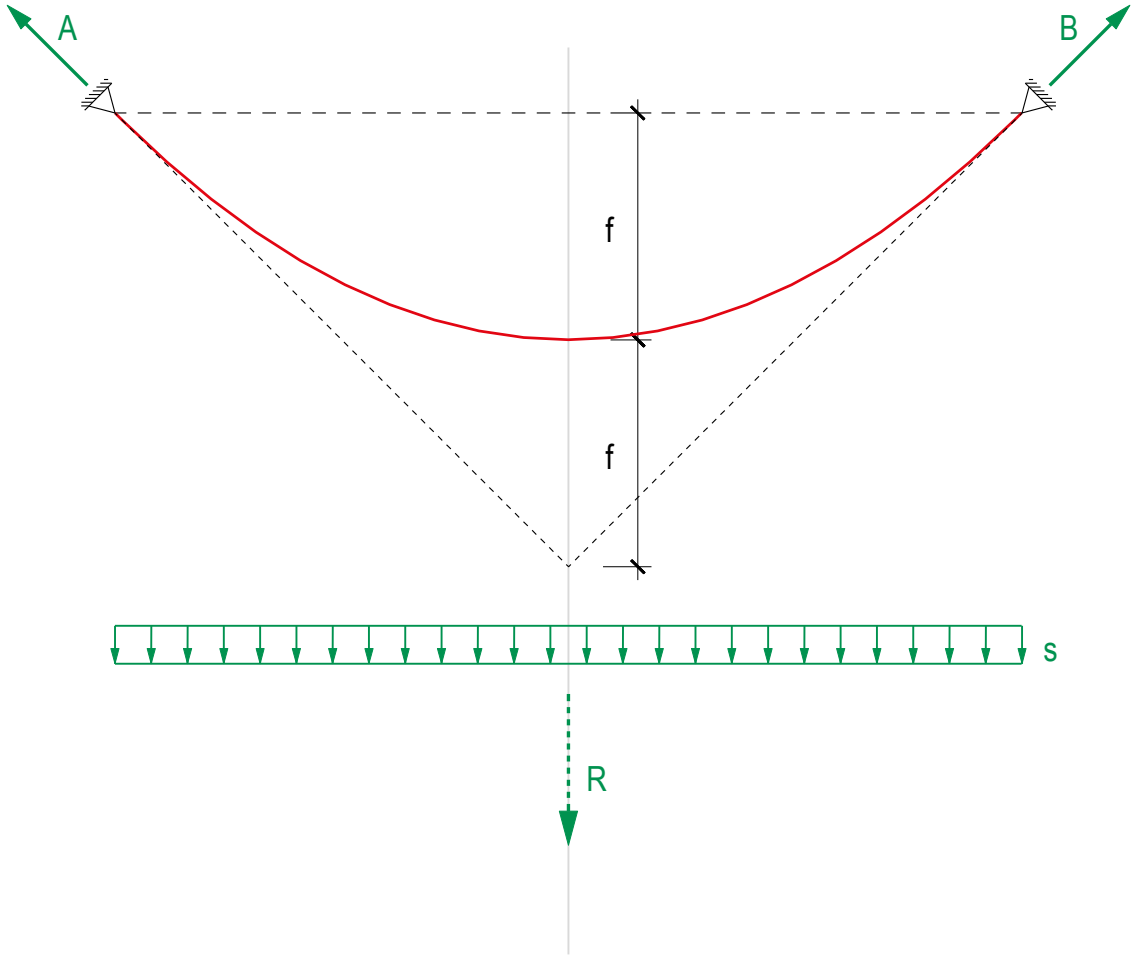

Lageplan 1:100  
*Form diagram 1:100*

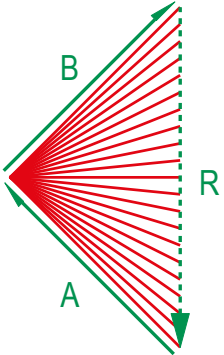

Kräfteplan 1 cm ≅ 1 kN  
*Force diagram 1 cm ≅ 1 kN*

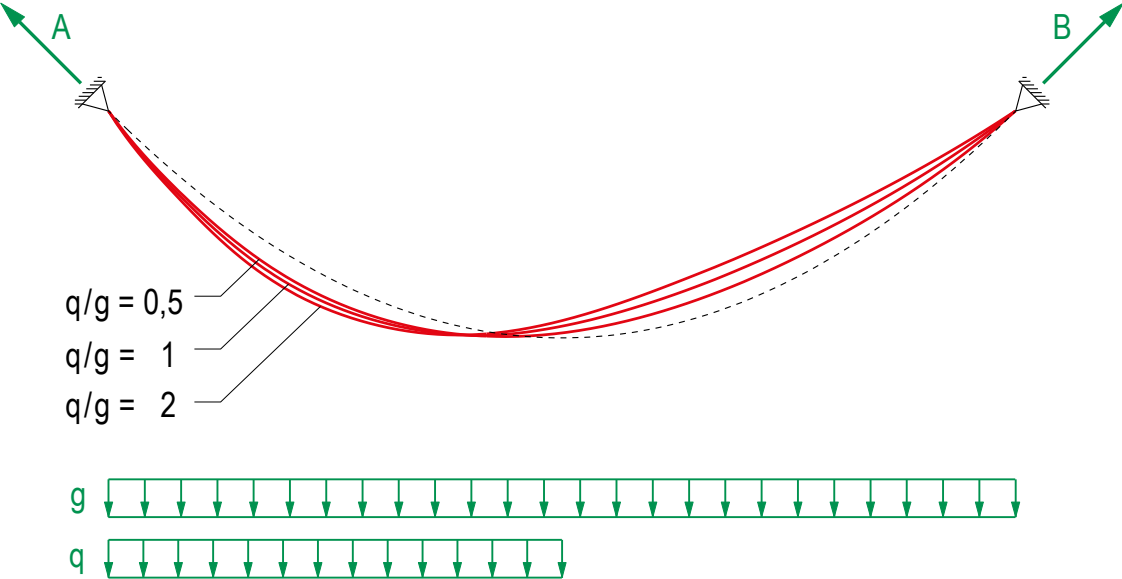

# Seile

## *Cables*

Tragwirkung eines Seils unter mehreren beliebigen Lasten

*A cable's reaction to a set of non-concurrent loads*

Tragwirkung eines Seils unter gleichmässig verteilter Belastung

*A cable's reaction to uniformly distributed loads*

Fallstudie: Golden Gate Brücke

*Case study: Golden Gate bridge*

Formänderung von Seiltragwerken

*Form-active behaviour of cables*

>> Aussteifung durch Erhöhung der Eigenlasten

*Stiffening by increasing dead loads*

Aussteifung durch Vorspannung

*Stiffening through prestressing*

Aussteifung mittels eines Fachwerks

*Stiffening using a truss*

Übersicht der Aussteifungssysteme

*Overview of stiffening schemes*

*Stiffening by increasing dead loads*

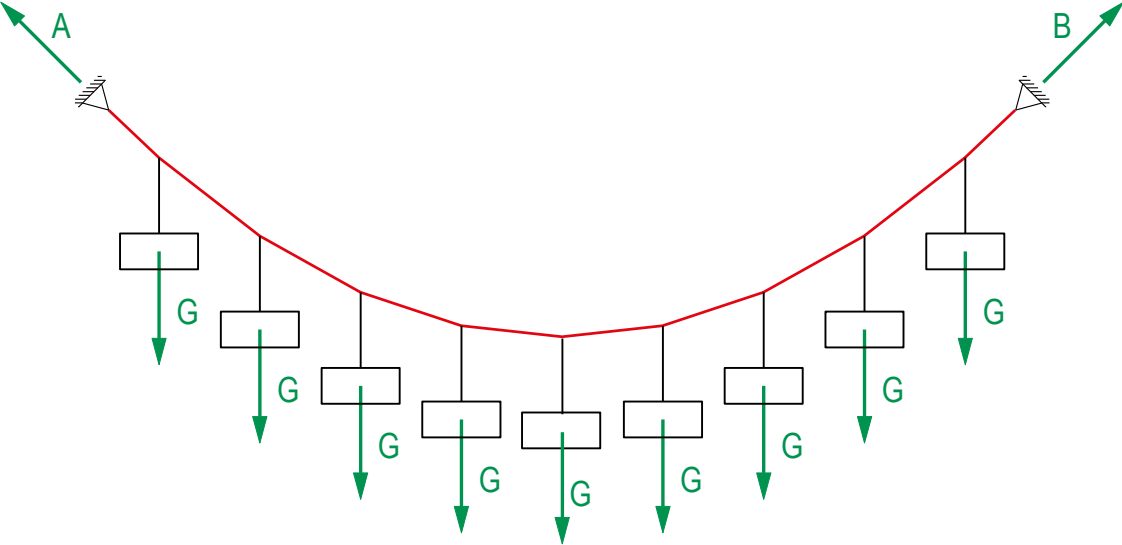





Le Corbusier: La maison de la culture, Firminy, 1965





Le Corbusier: La maison de la culture, Firminy, 1965





Alvaro Siza, Cecil Balmond: Expo Pavillion of Portugal, Lisbon, 1998

# Seile

## *Cables*

Tragwirkung eines Seils unter mehreren beliebigen Lasten

*A cable's reaction to a set of non-concurrent loads*

Tragwirkung eines Seils unter gleichmässig verteilter Belastung

*A cable's reaction to uniformly distributed loads*

Fallstudie: Golden Gate Brücke

*Case study: Golden Gate bridge*

Formänderung von Seiltragwerken

*Form-active behaviour of cables*

Aussteifung durch Erhöhung der Eigenlasten

*Stiffening by increasing dead loads*

>>

Aussteifung durch Vorspannung

*Stiffening through prestressing*

Aussteifung mittels eines Fachwerks

*Stiffening using a truss*

Übersicht der Aussteifungssysteme

*Overview of stiffening schemes*

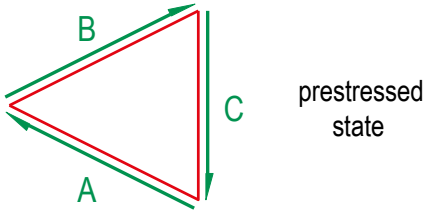
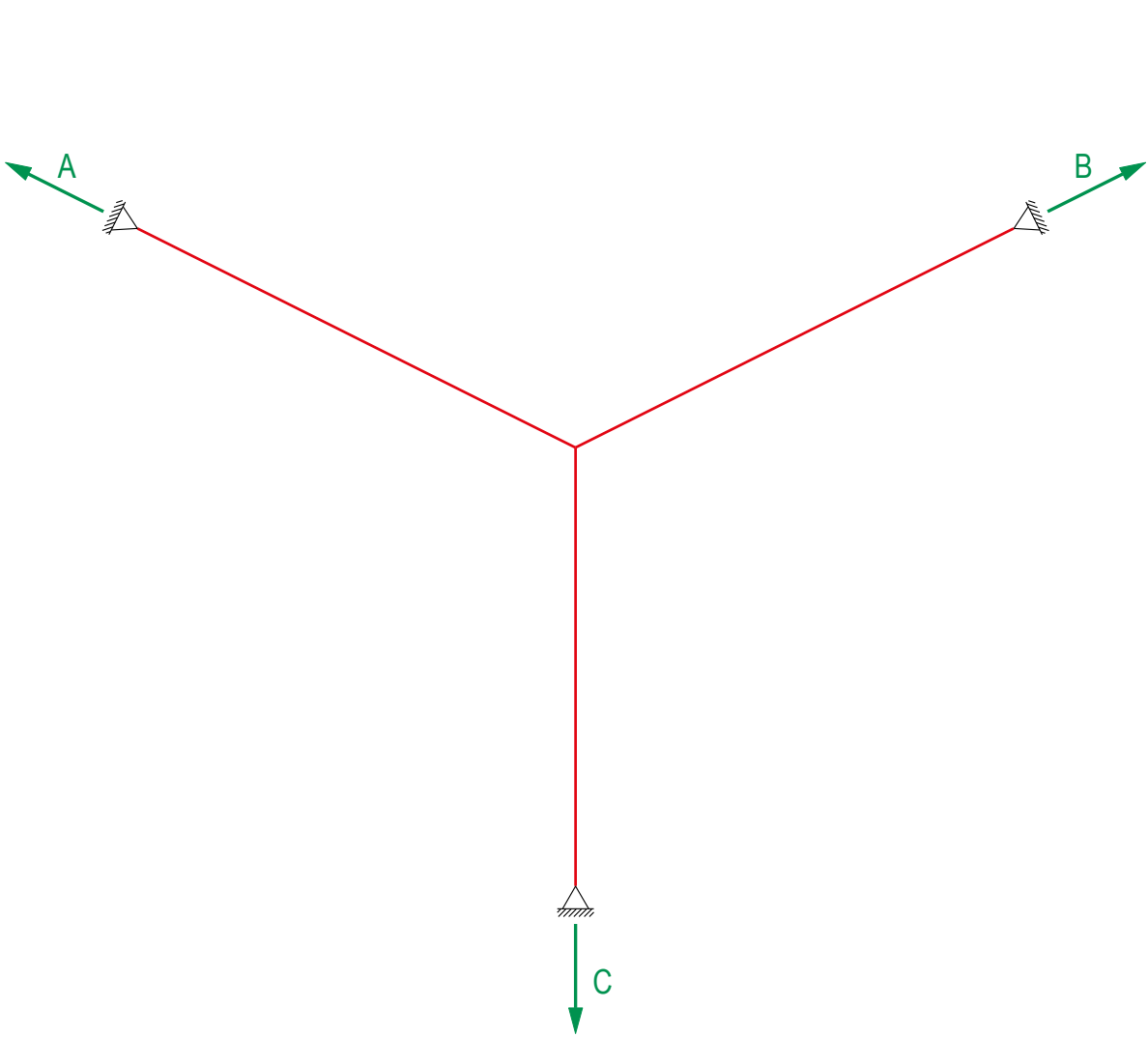

Lageplan 1:100  
*Form diagram 1:100*

Kräfteplan 1 cm  $\cong$  1 kN  
*Force diagram 1 cm  $\cong$  1 kN*

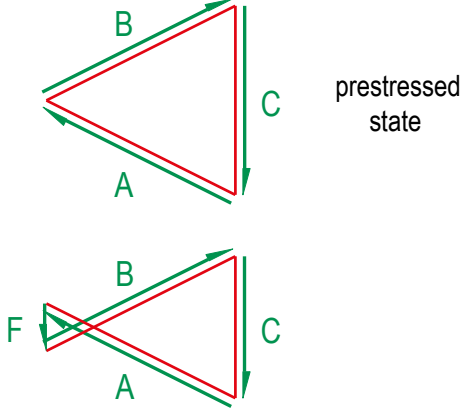
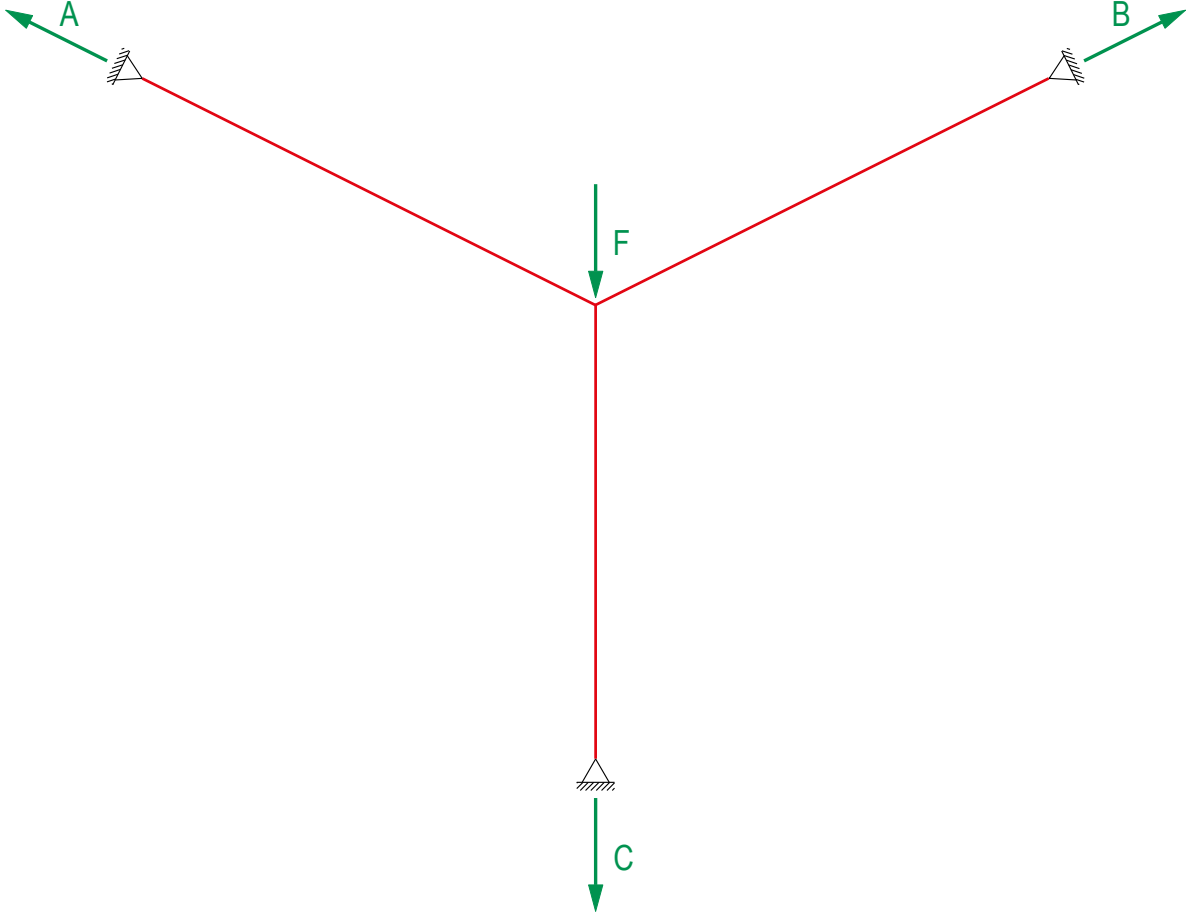

Lageplan 1:100  
*Form diagram 1:100*

Kräfteplan 1 cm ≙ 1 kN  
*Force diagram 1 cm ≙ 1 kN*

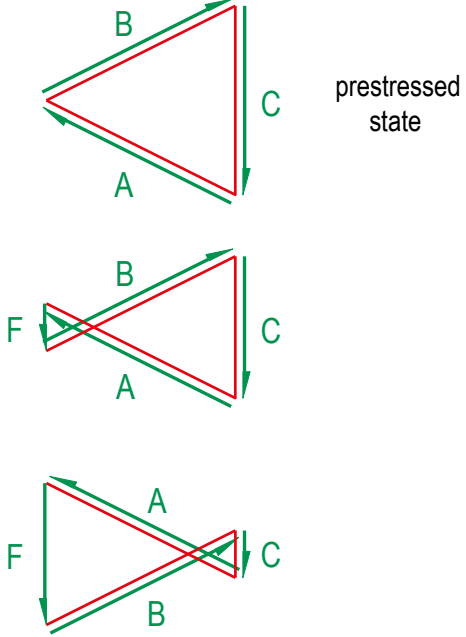
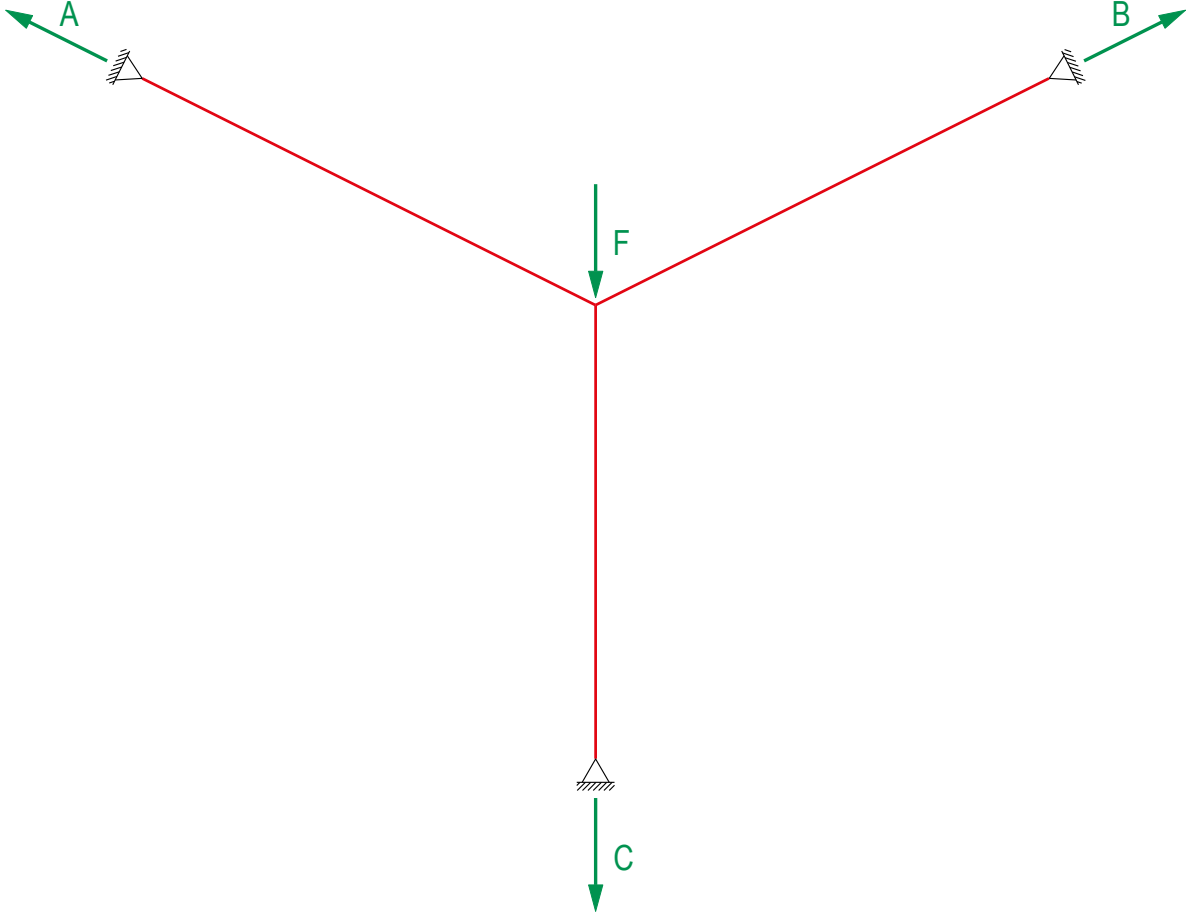

Lageplan 1:100  
*Form diagram 1:100*

Kräfteplan 1 cm ≙ 1 kN  
*Force diagram 1 cm ≙ 1 kN*

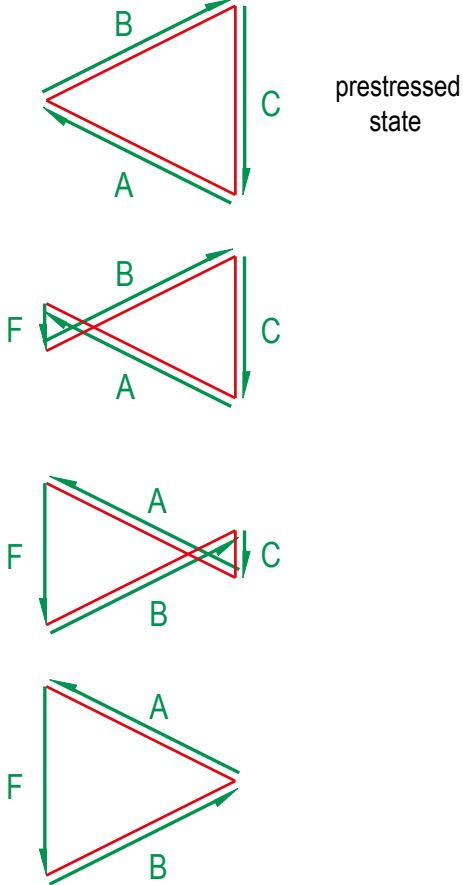
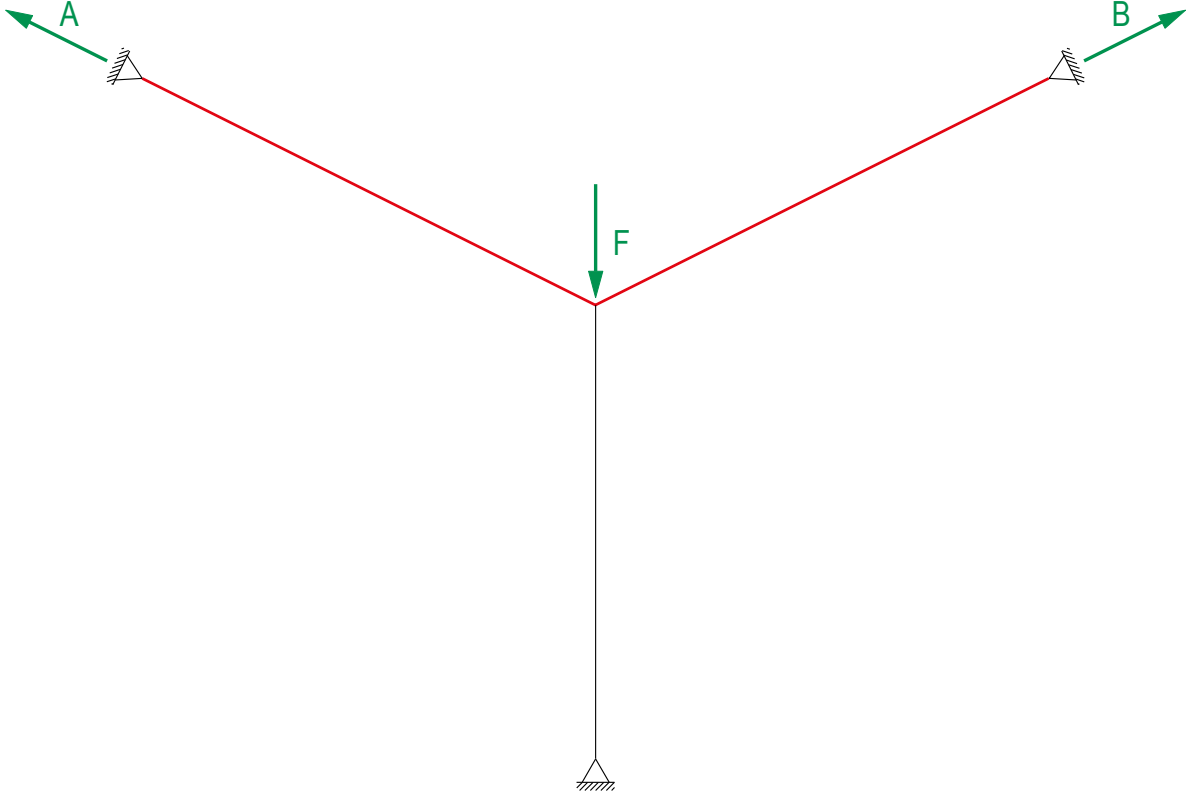

Lageplan 1:100  
*Form diagram 1:100*

Kräfteplan 1 cm ≙ 1 kN  
*Force diagram 1 cm ≙ 1 kN*



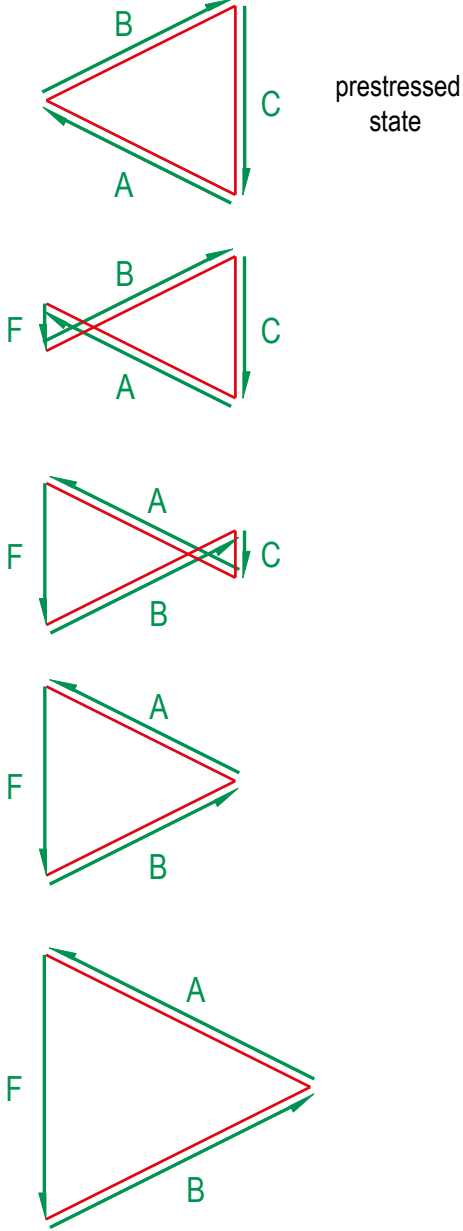
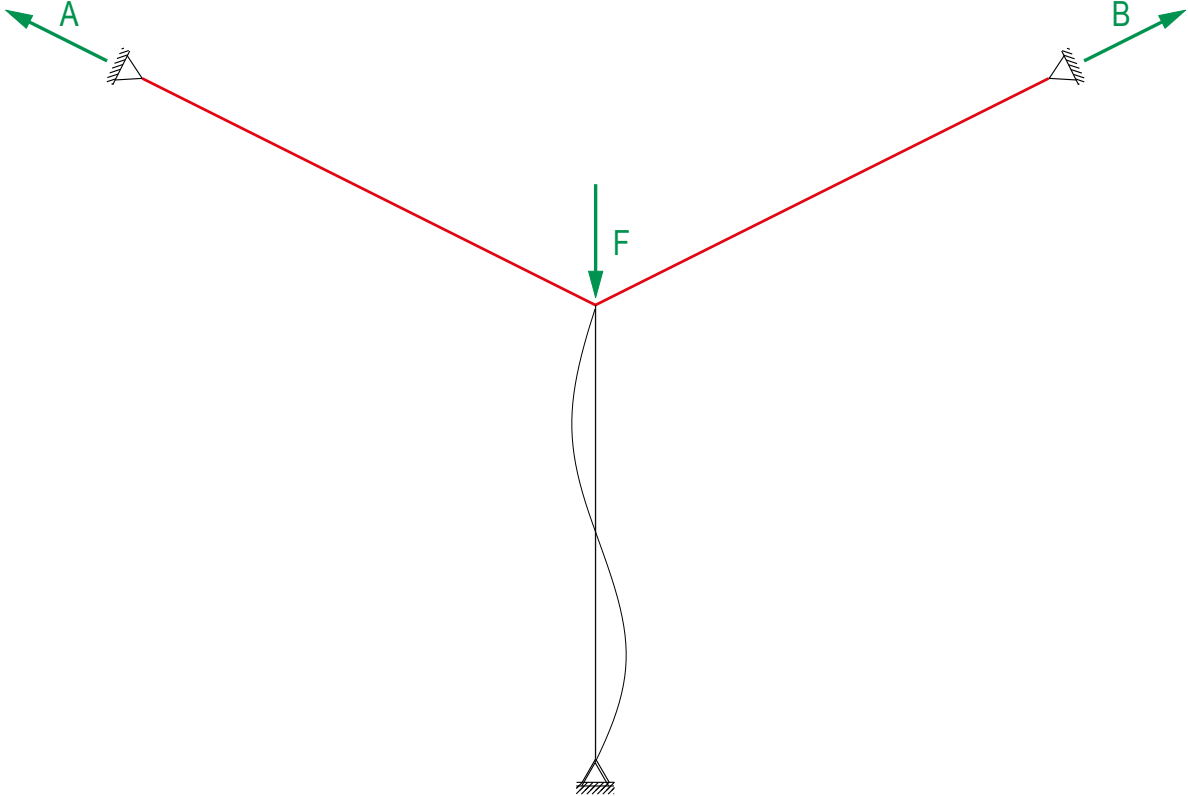

Lageplan 1:100  
*Form diagram 1:100*

Kräfteplan 1 cm  $\cong$  1 kN  
*Force diagram 1 cm  $\cong$  1 kN*

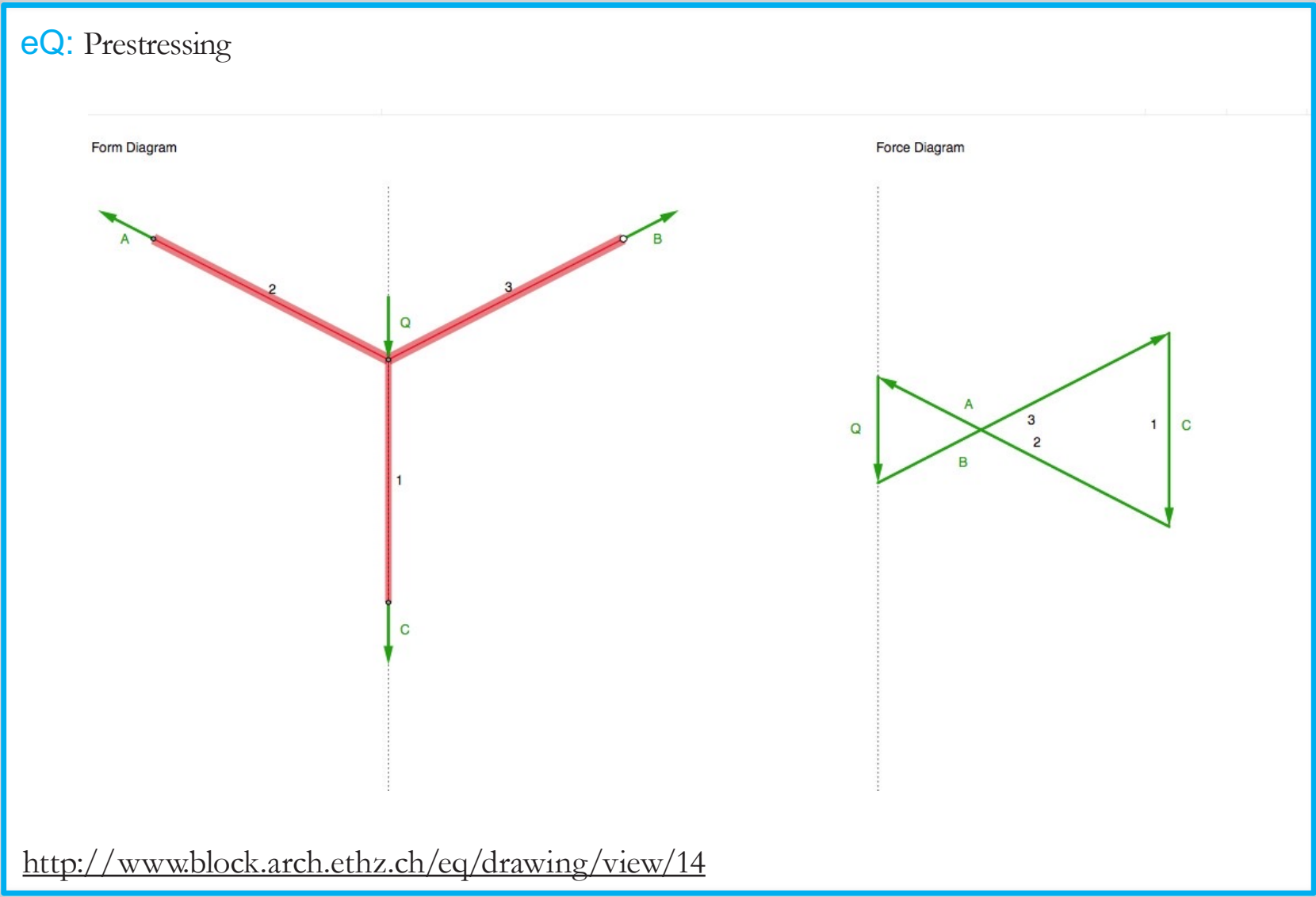

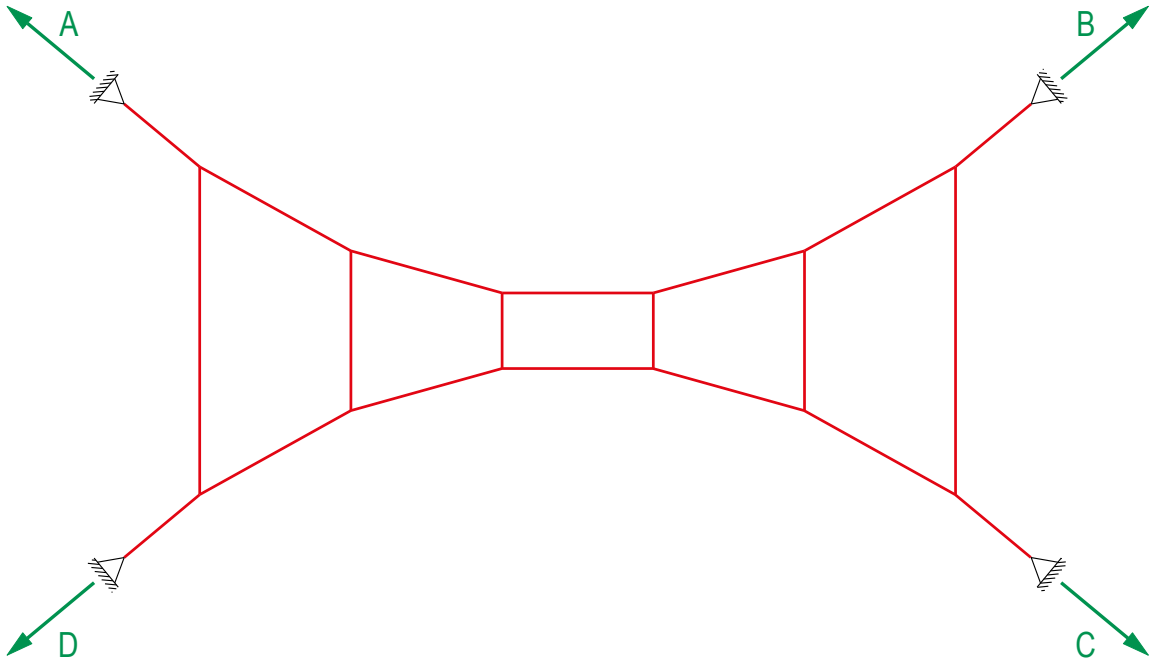

Lageplan 1:100  
*Form diagram 1:100*

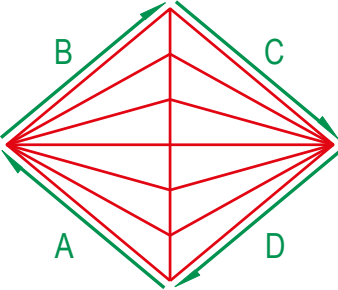

Kräfteplan 1 cm  $\cong$  1 kN  
*Force diagram 1 cm  $\cong$  1 kN*

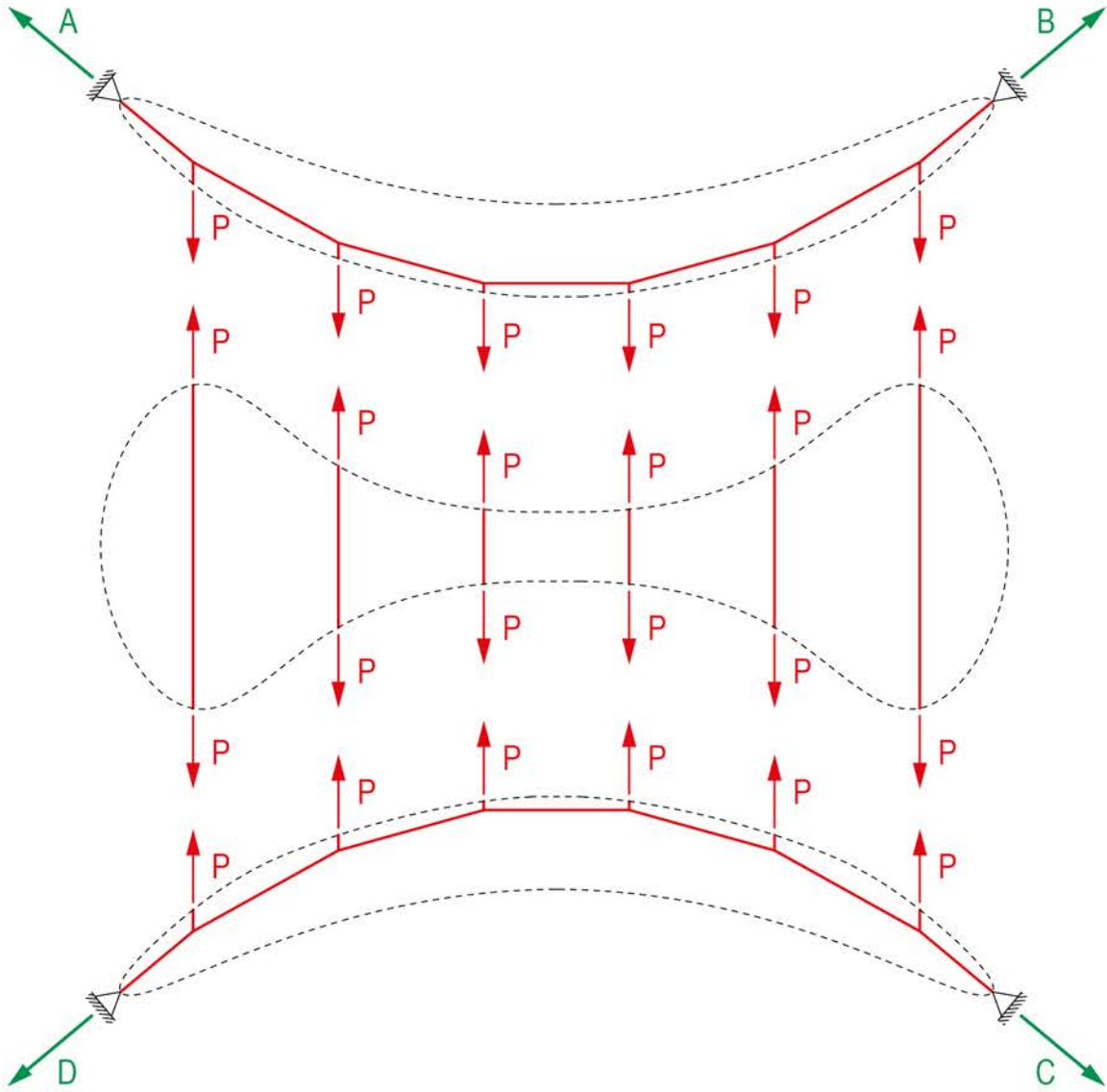

Lageplan 1:100  
*Form diagram 1:100*

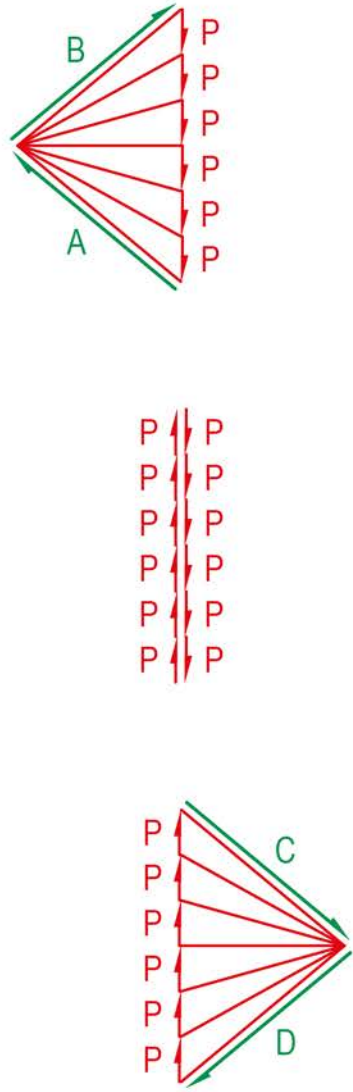

Kräfteplan 1 cm ≅ 1 kN  
*Force diagram 1 cm ≅ 1 kN*

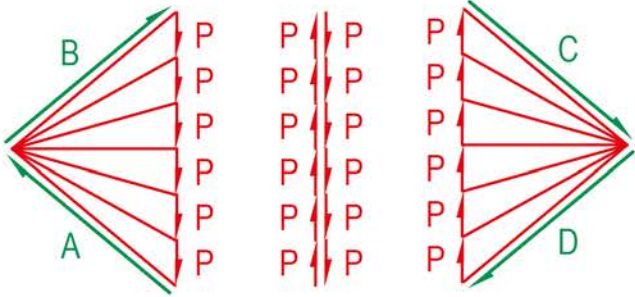
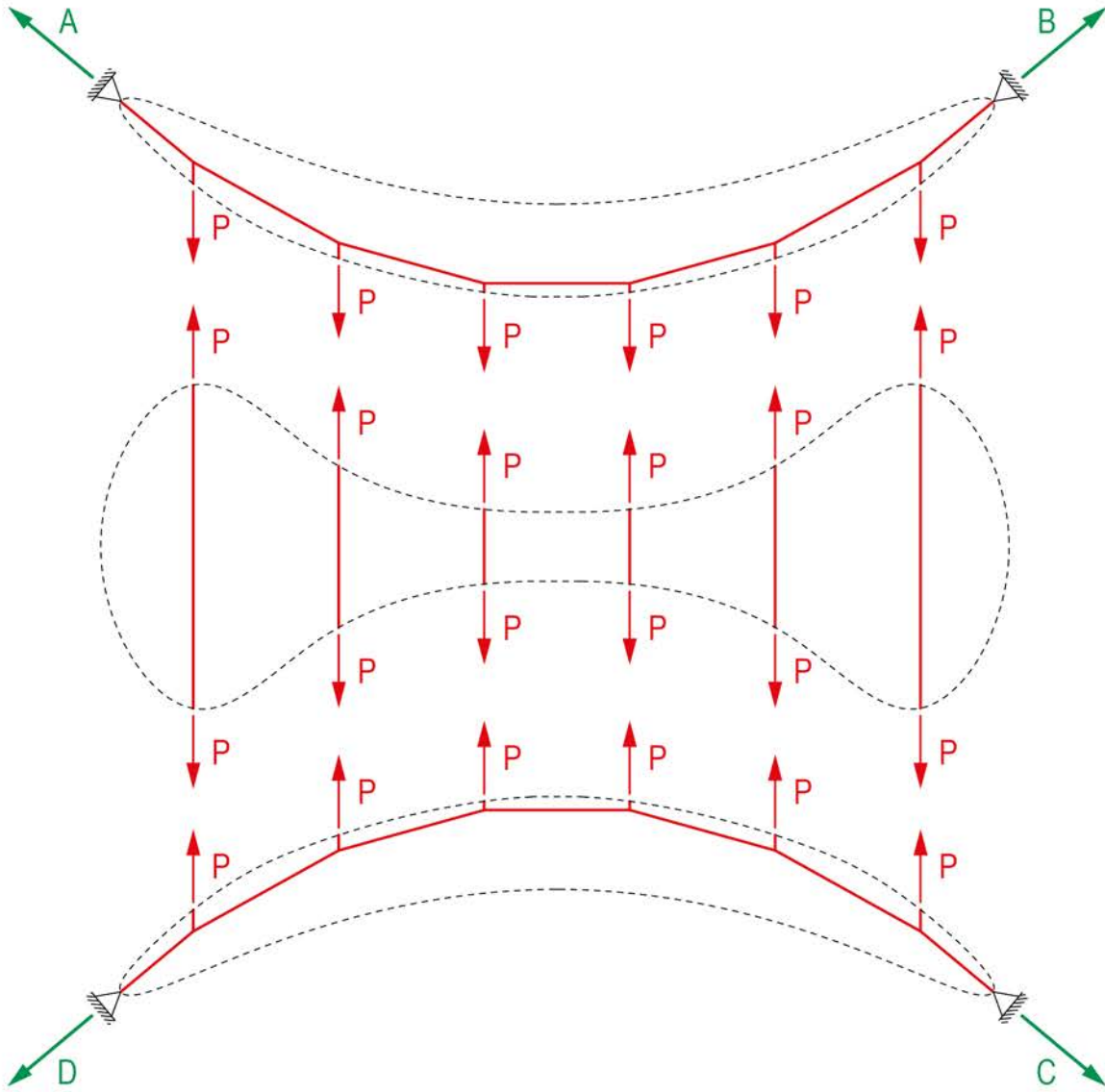

Lageplan 1:100  
Form diagram 1:100

Kräfteplan 1 cm ≅ 1 kN  
Force diagram 1 cm ≅ 1 kN

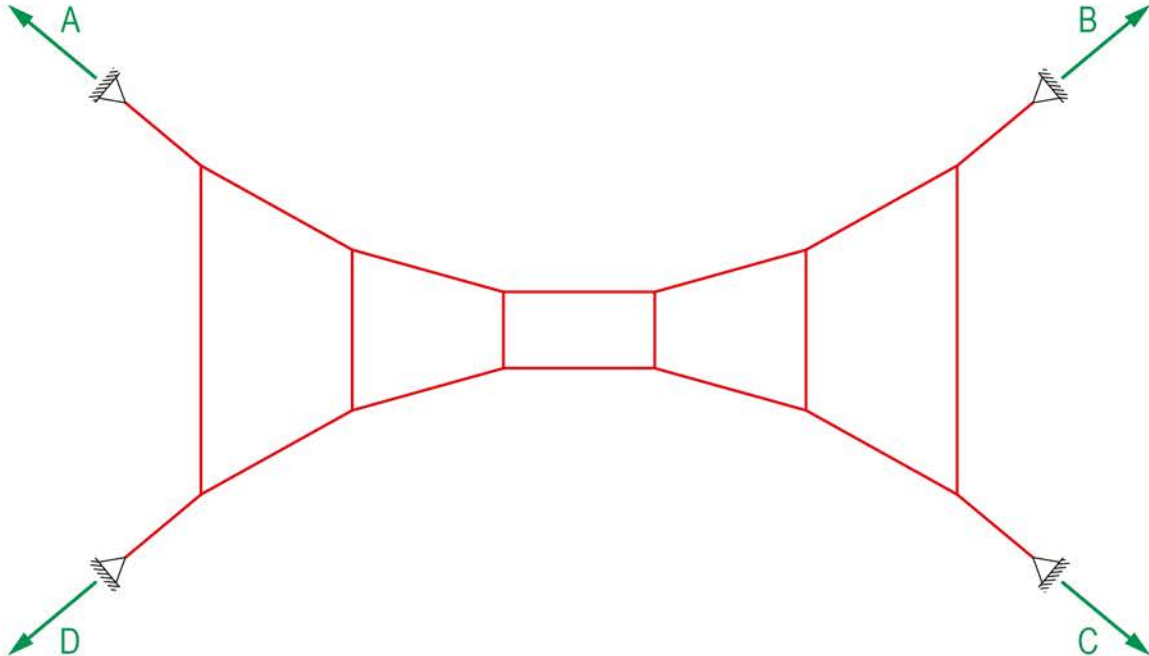

Lageplan 1:100  
*Form diagram 1:100*

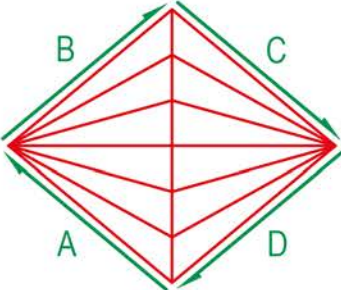

Kräfteplan 1 cm ≅ 1 kN  
*Force diagram 1 cm ≅ 1 kN*

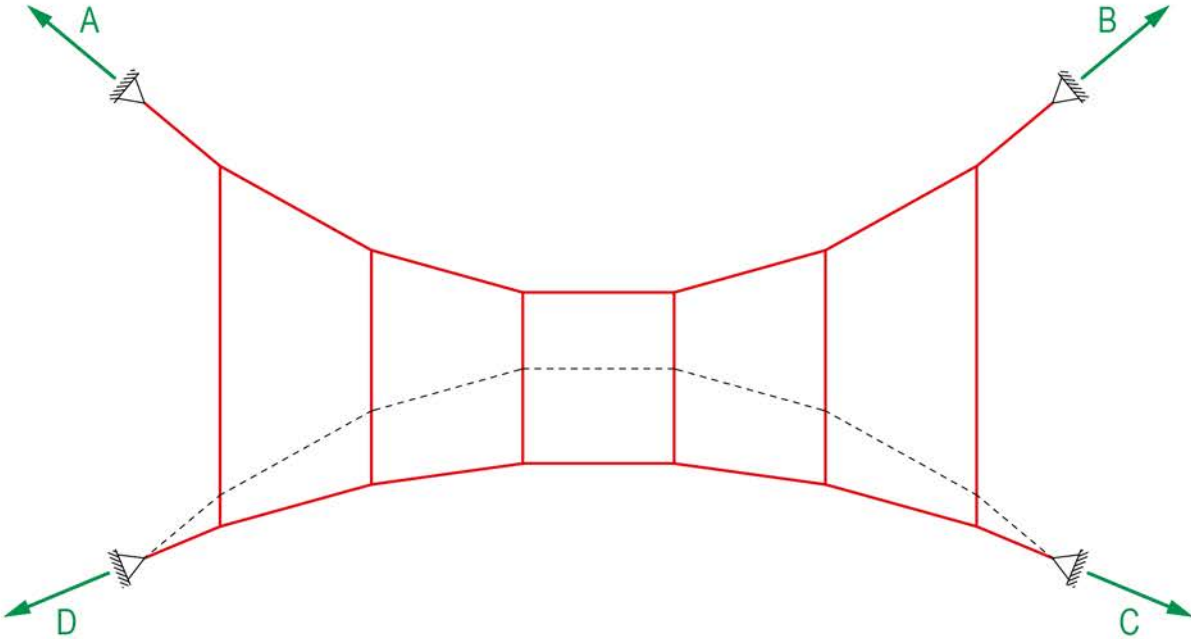

Lageplan 1:100  
*Form diagram 1:100*

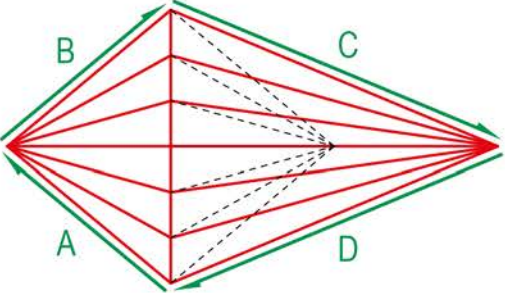

Kräfteplan 1 cm ≅ 1 kN  
*Force diagram 1 cm ≅ 1 kN*

eQ: Complex Prestress

Form Diagram

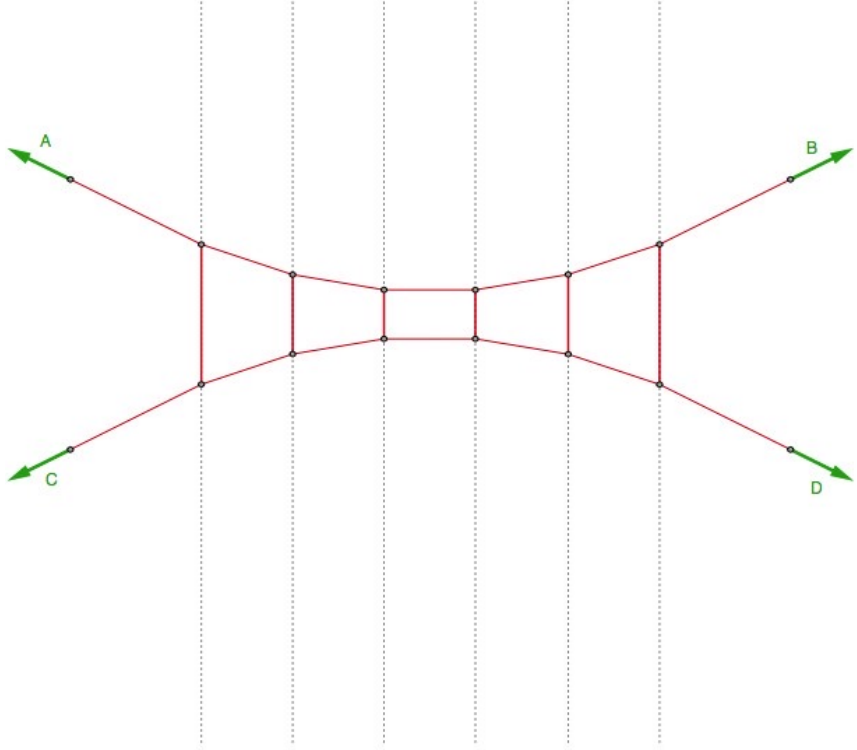

Force Diagram

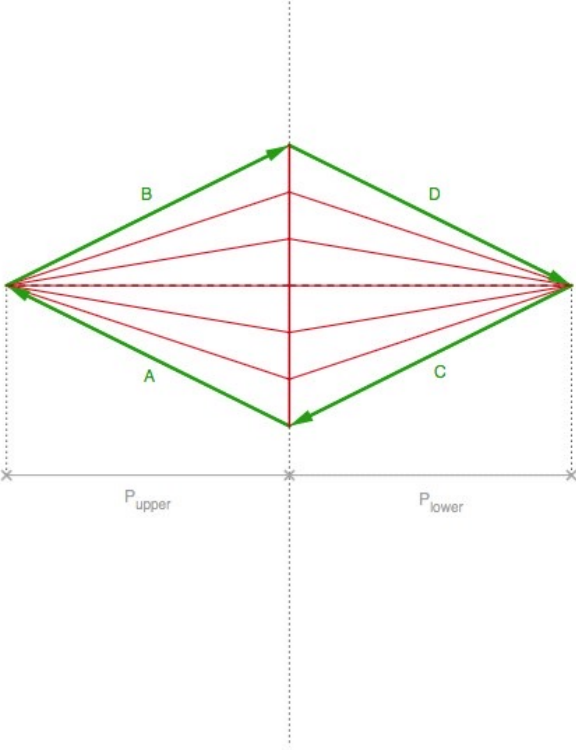

<http://www.block.arch.ethz.ch/eq/drawing/view/12>





Veil & Jörg Steli, Th. Zoidl, Fussgängerbrücke Bruneck, Innsbruck, 2004



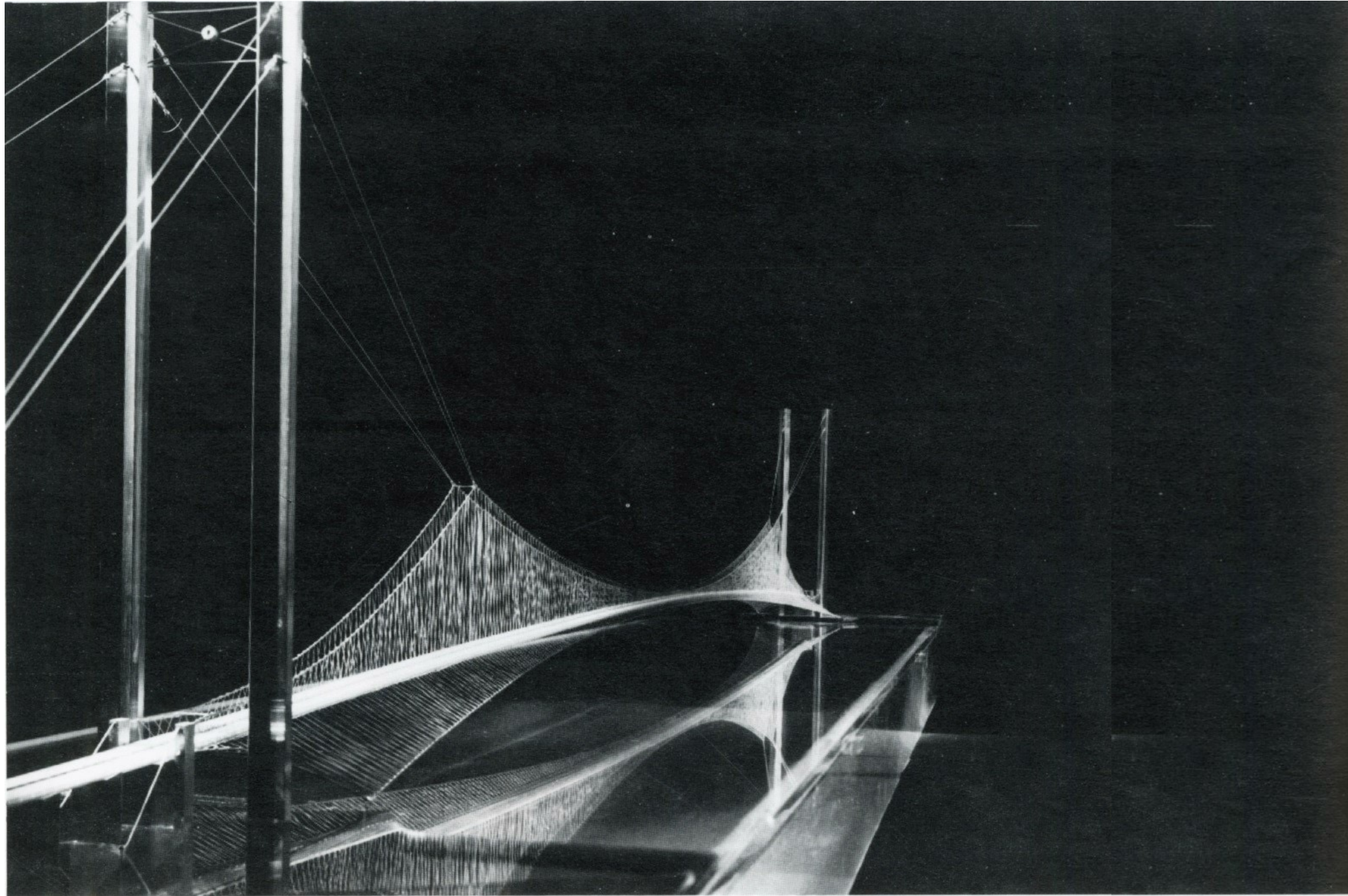

Sergio Musmeci, Wettbewerb für Ponte Messina, 1970

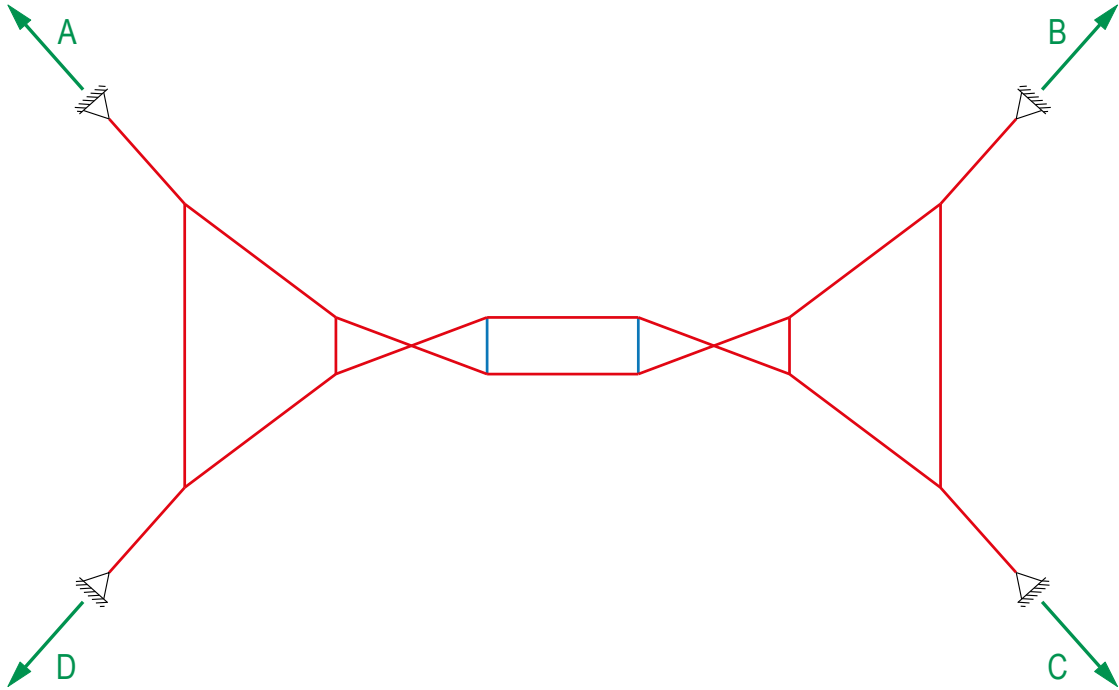

Lageplan 1:100  
*Form diagram 1:100*

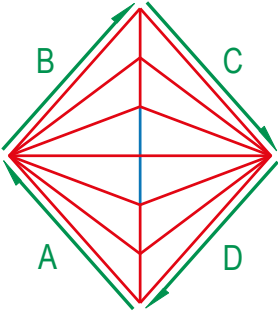

Kräfteplan 1 cm  $\cong$  1 kN  
*Force diagram 1 cm  $\cong$  1 kN*

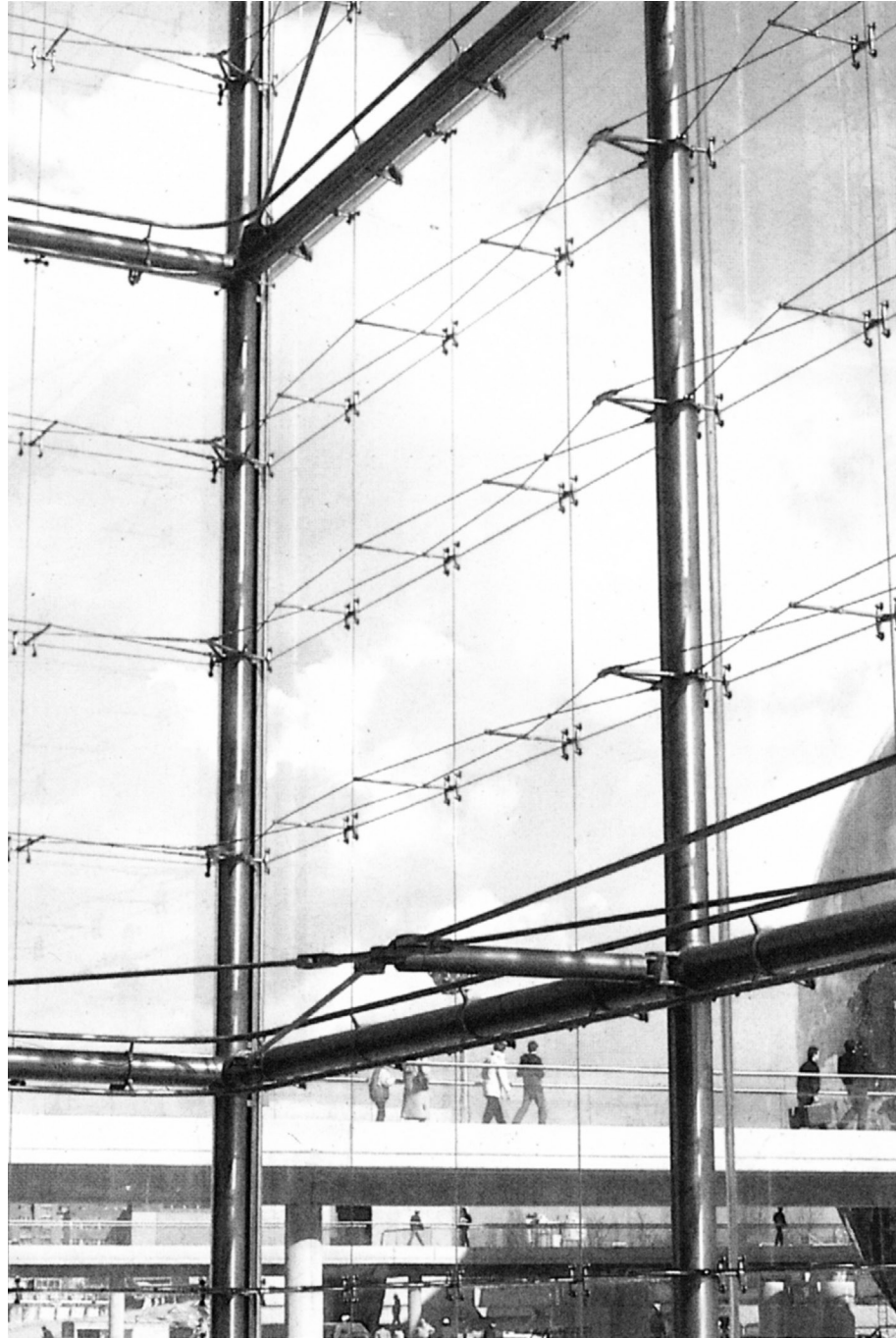

Peter Rice: Parc de la villette, Paris, 1981



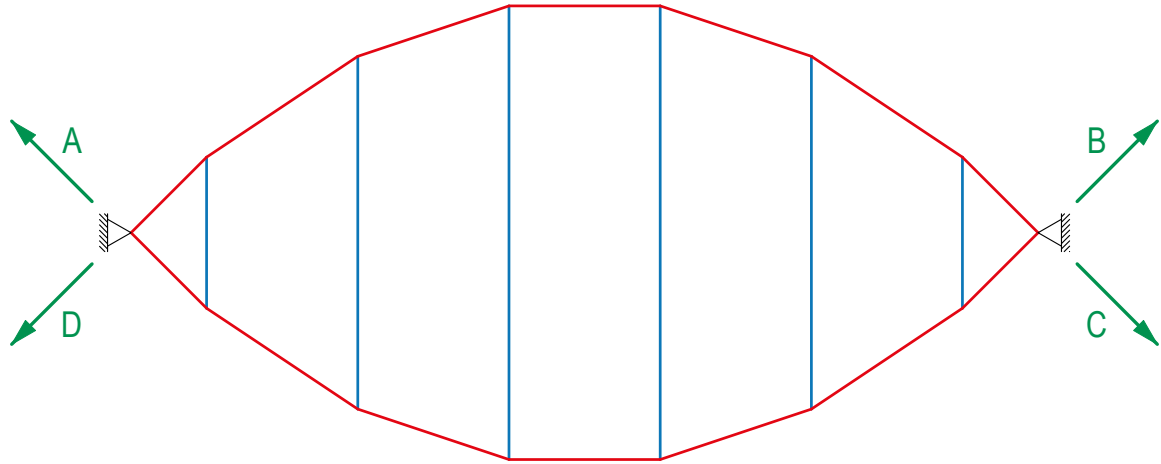

Lageplan 1:100  
*Form diagram 1:100*

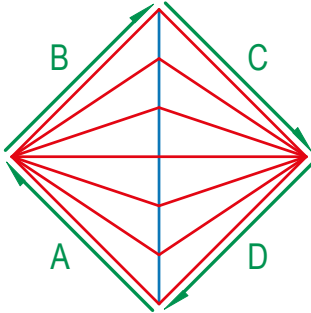

Kräfteplan 1 cm  $\cong$  1 kN  
*Force diagram 1 cm  $\cong$  1 kN*

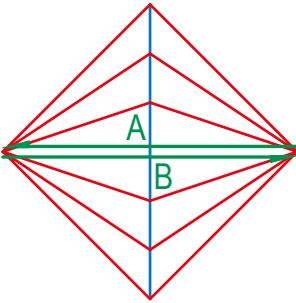
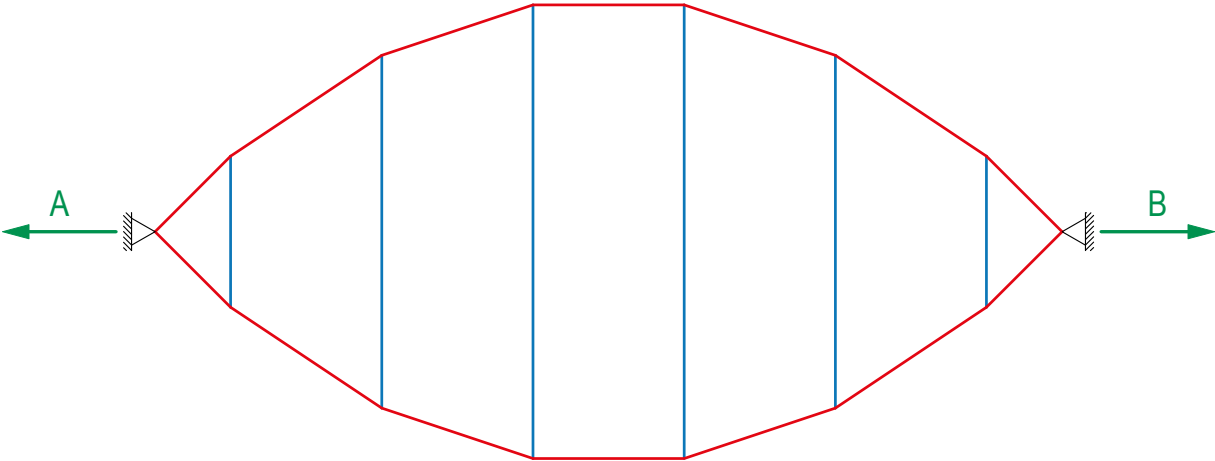

Lageplan 1:100

*Form diagram 1:100*

Kräfteplan 1 cm  $\cong$  1 kN

*Force diagram 1 cm  $\cong$  1 kN*



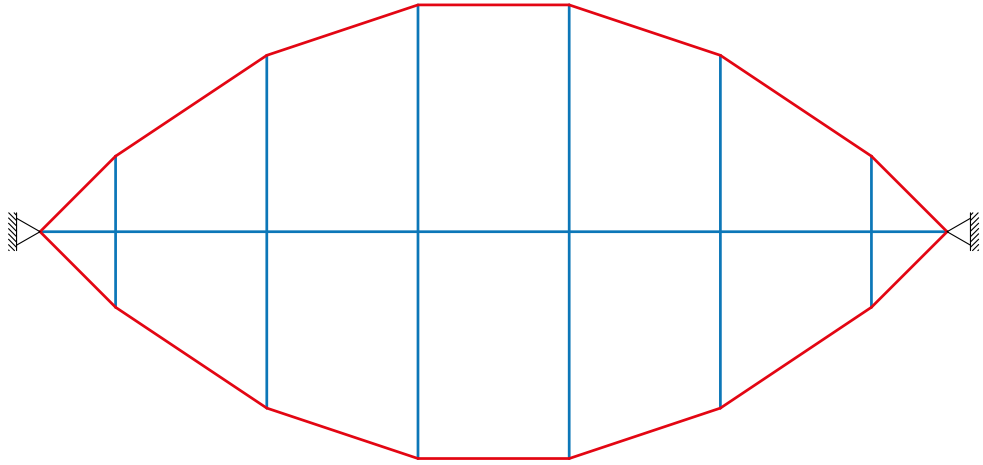

Lageplan 1:100  
*Form diagram 1:100*

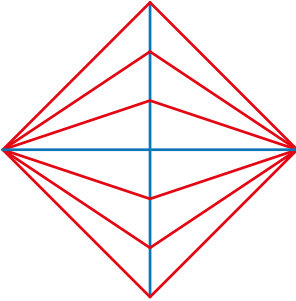

Kräfteplan 1 cm ≙ 1 kN  
*Force diagram 1 cm ≙ 1 kN*



Renzo Piano: Kansai International Airport, Osaka, 1994

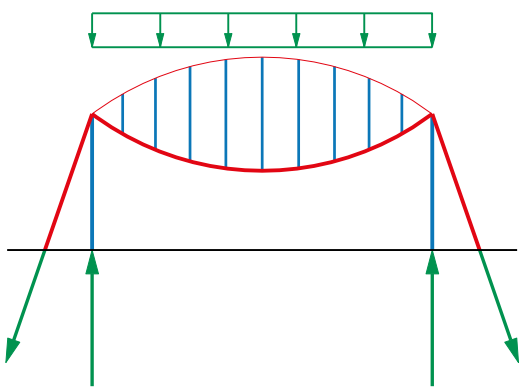
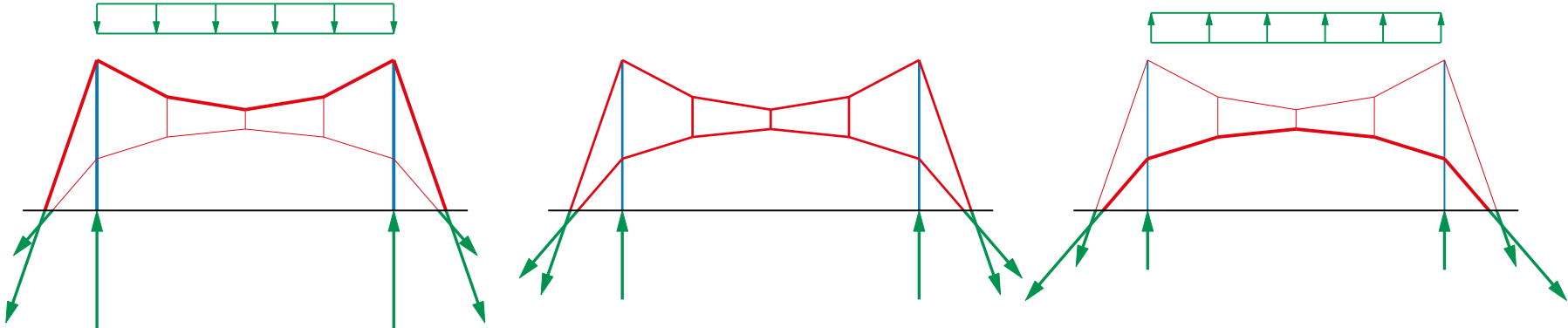

Winddruck  
*Wind pressure*

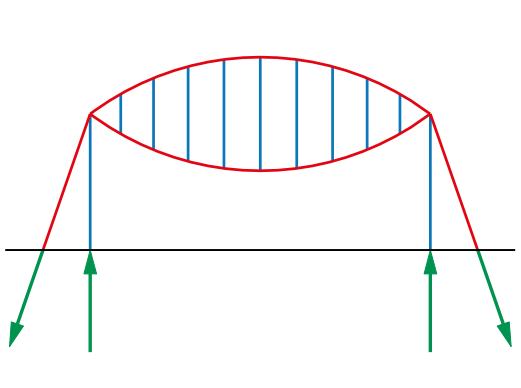

Ausgangslage  
*Initial situation*

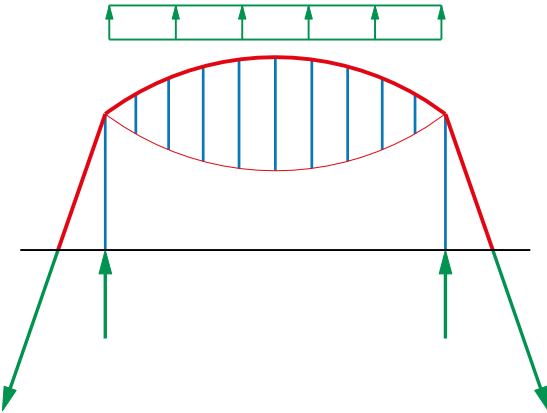

Windsog  
*Wind suction*

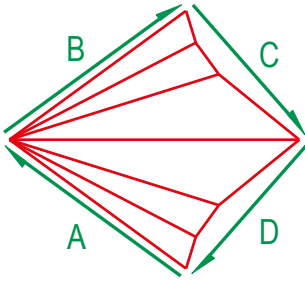
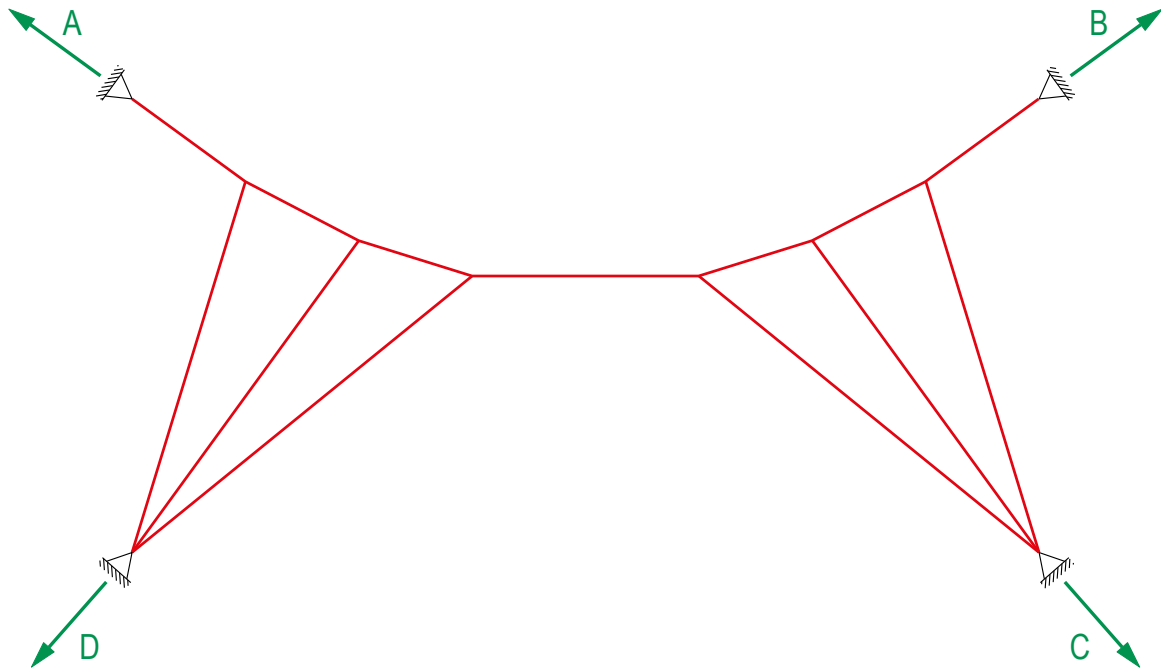

Lageplan 1:100  
*Form diagram 1:100*

Kräfteplan 1 cm  $\cong$  1 kN  
*Force diagram 1 cm  $\cong$  1 kN*

$q_1 < q_2$

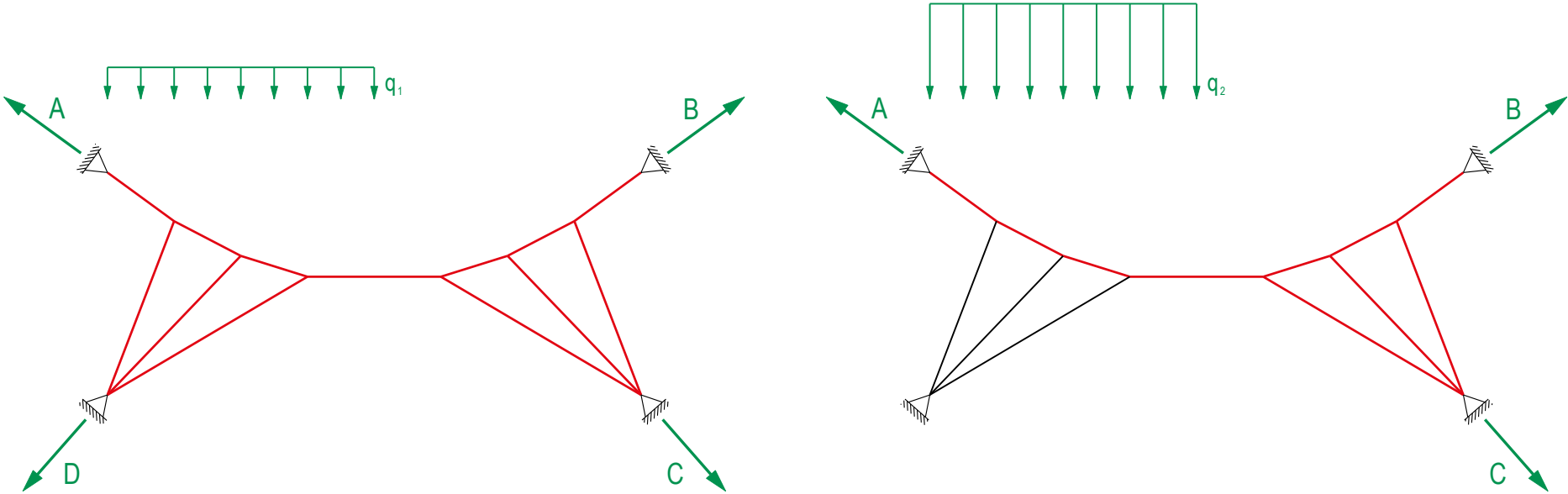





Herzog and Partner, Schlaich Bergermann and Partner: Exhibition Center 26, Hannover, 1996

# Seile

## *Cables*

Tragwirkung eines Seils unter mehreren beliebigen Lasten

*A cable's reaction to a set of non-concurrent loads*

Tragwirkung eines Seils unter gleichmässig verteilter Belastung

*A cable's reaction to uniformly distributed loads*

Fallstudie: Golden Gate Brücke

*Case study: Golden Gate bridge*

Formänderung von Seiltragwerken

*Form-active behaviour of cables*

Aussteifung durch Erhöhung der Eigenlasten

*Stiffening by increasing dead loads*

Aussteifung durch Vorspannung

*Stiffening through prestressing*

>>

Aussteifung mittels eines Fachwerks

*Stiffening using a truss*

Übersicht der Aussteifungssysteme

*Overview of stiffening schemes*

*Stiffening using a truss*

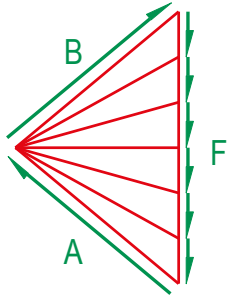
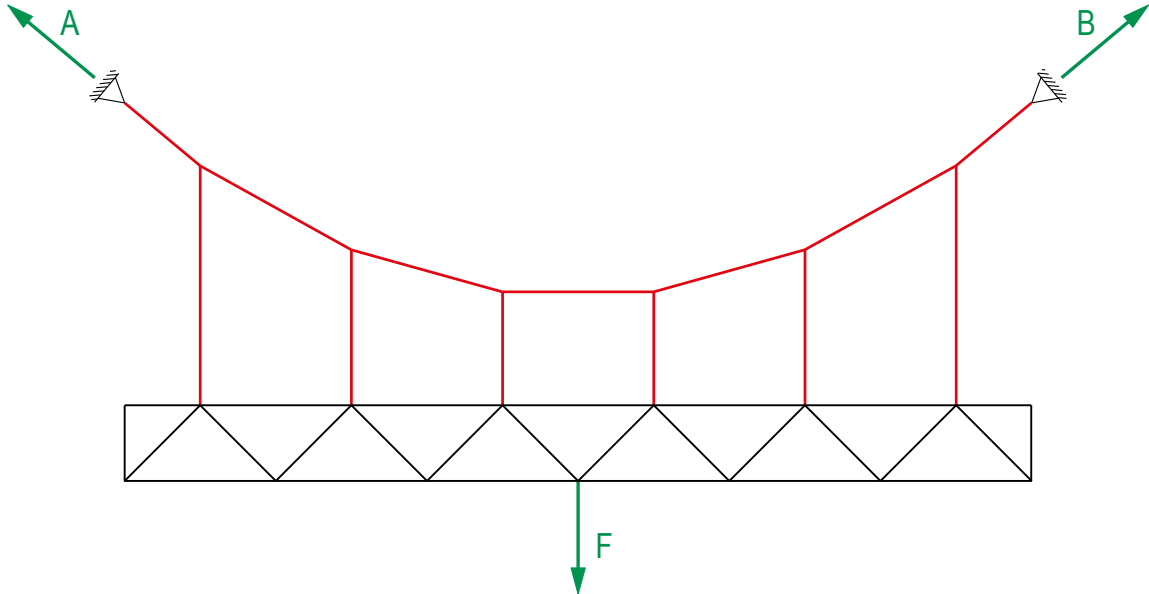

Lageplan 1:100

*Form diagram 1:100*

Kräfteplan 1 cm  $\cong$  1 kN

*Force diagram 1 cm  $\cong$  1 kN*

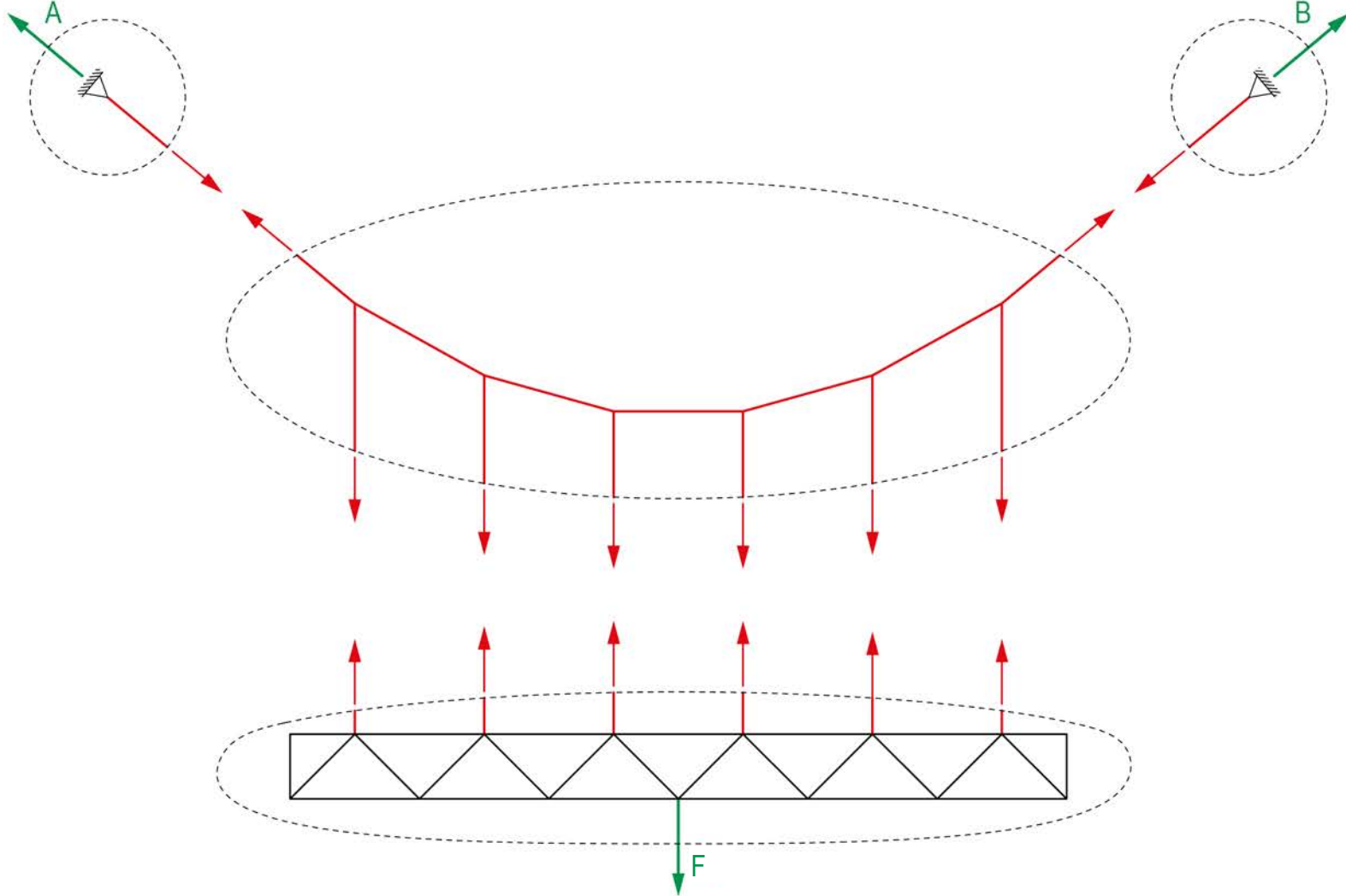





Othmar Ammann: George Washington Bridge, New York, 1931





Othmar Ammann: George Washington Bridge, New York, 1931

*Stiffening using a truss*

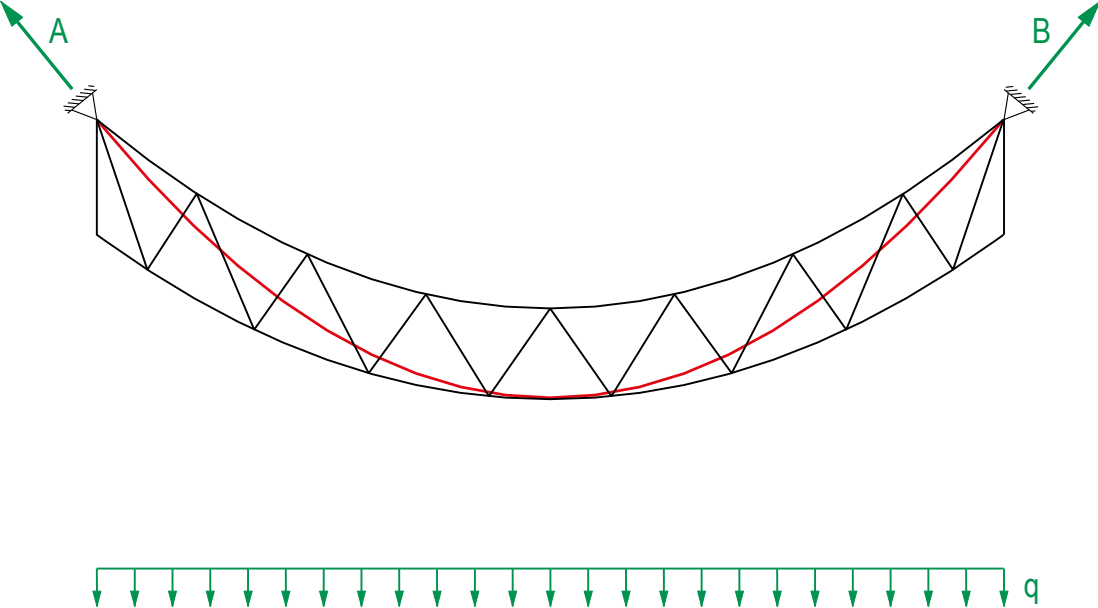



Kenzo Tange: Olympic Stadium, Tokyo, 1964



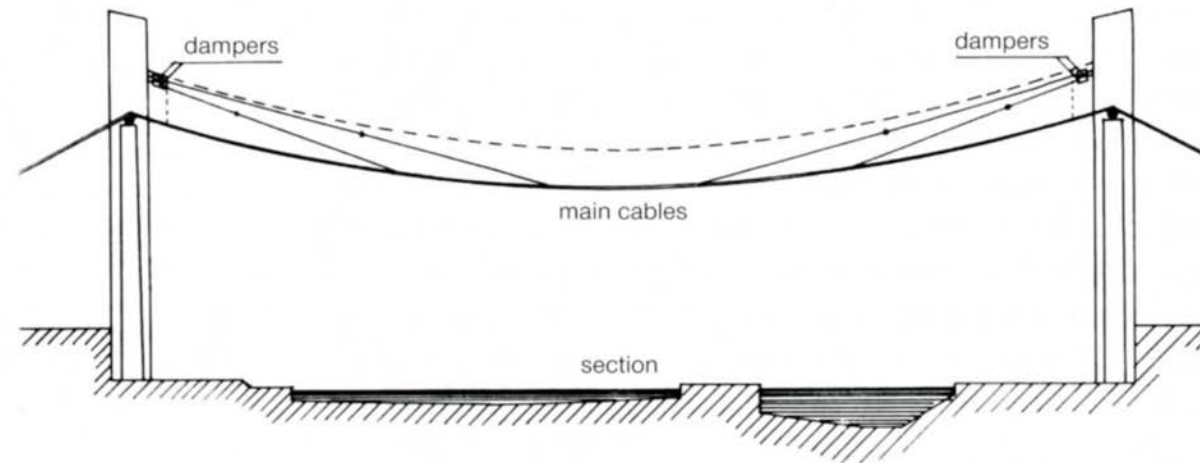
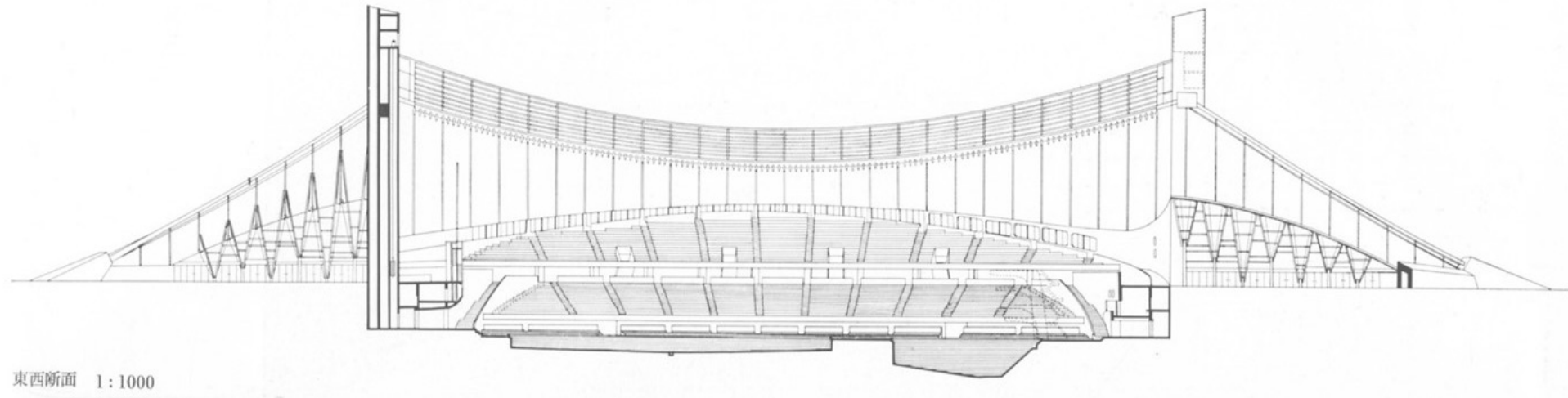

*Stiffening using a truss*

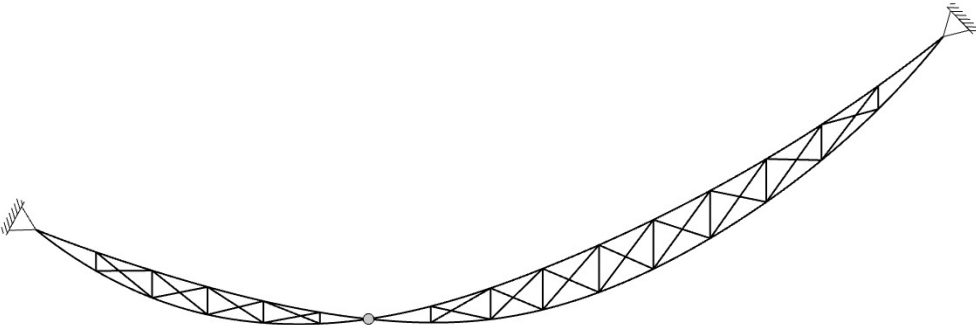



*Stiffening using a truss*

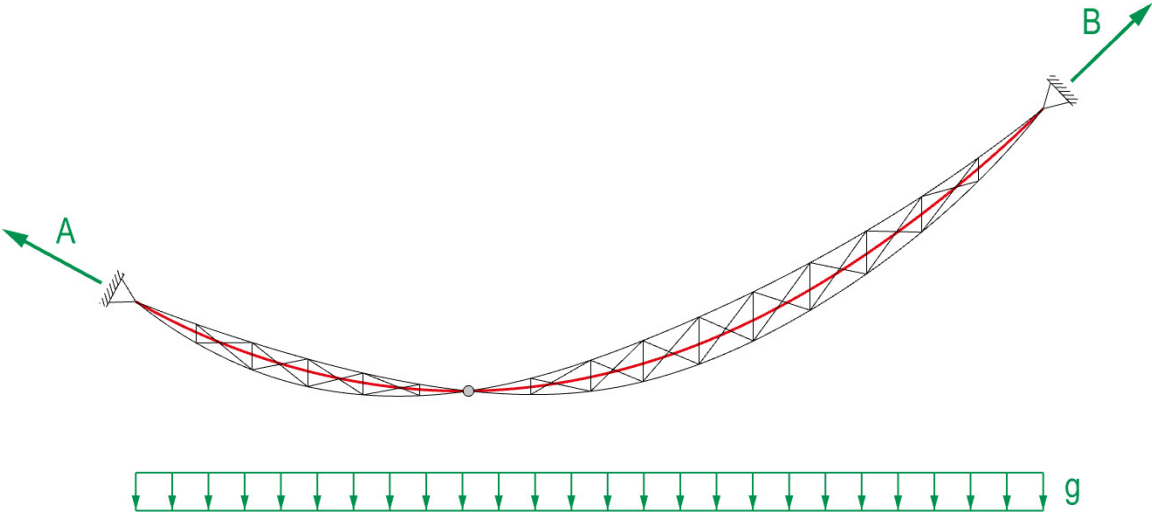

*Stiffening using a truss*

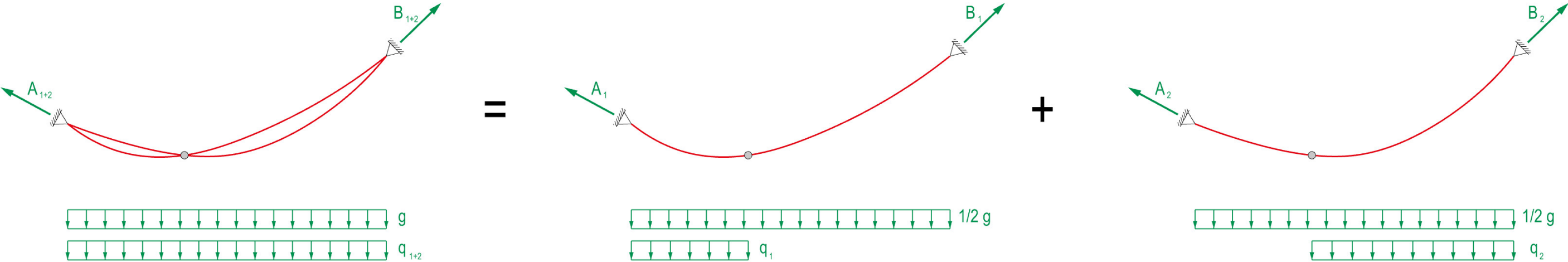



Sir Horace Jones and Sir John Wolfe Barry: Tower Bridge, London, 1894

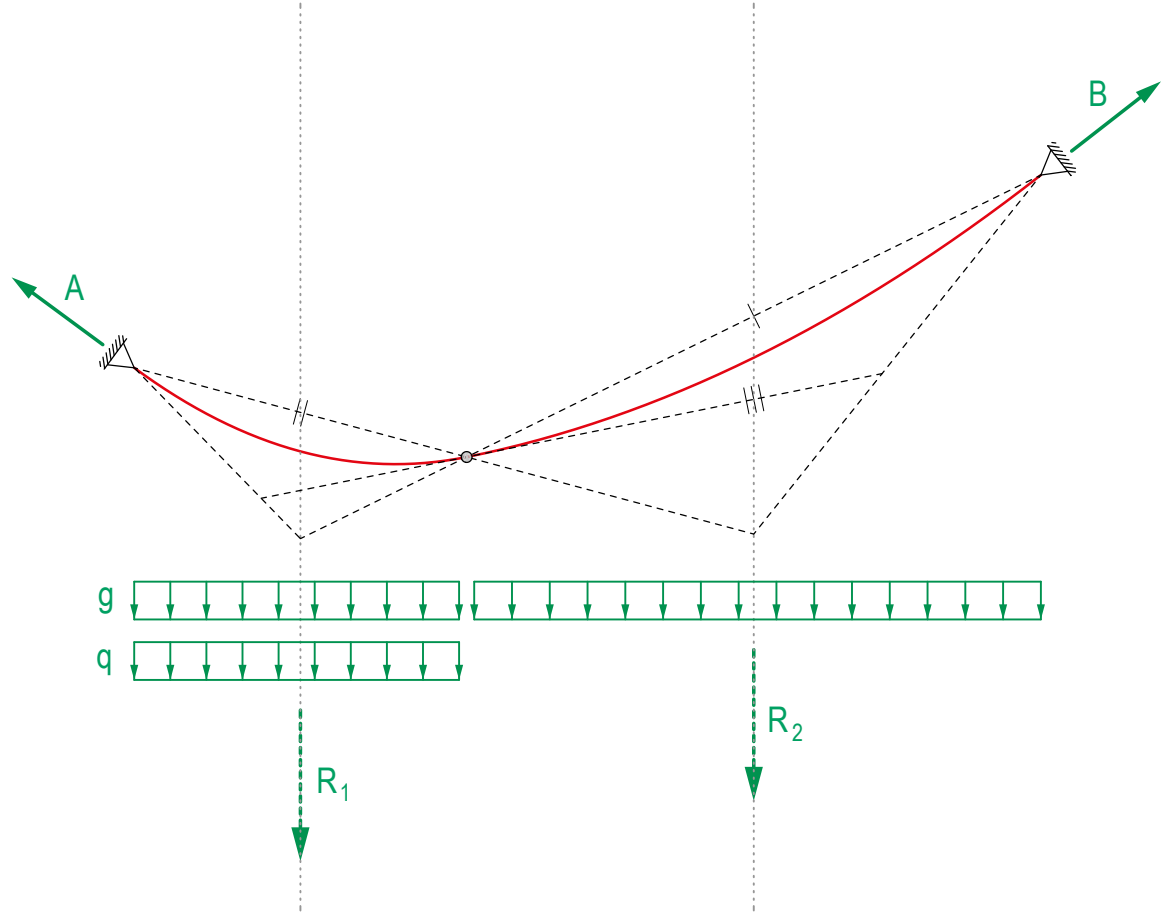

Lageplan 1:100  
*Form diagram 1:100*

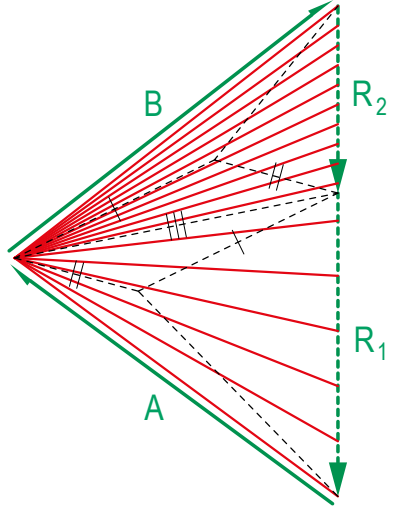

Kräfteplan 1 cm ≙ 1 kN  
*Force diagram 1 cm ≙ 1 kN*

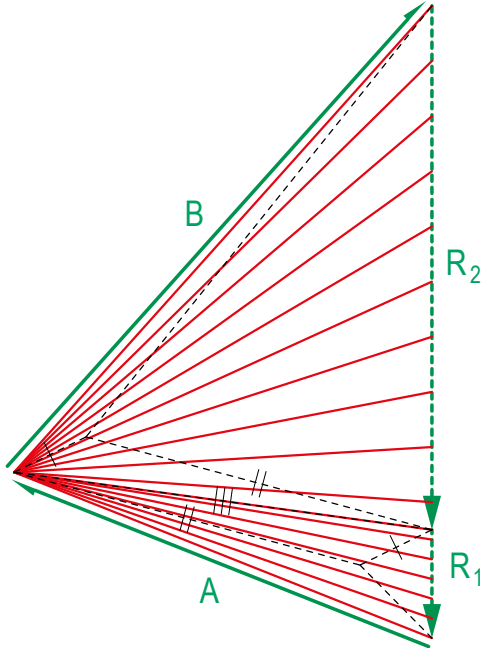
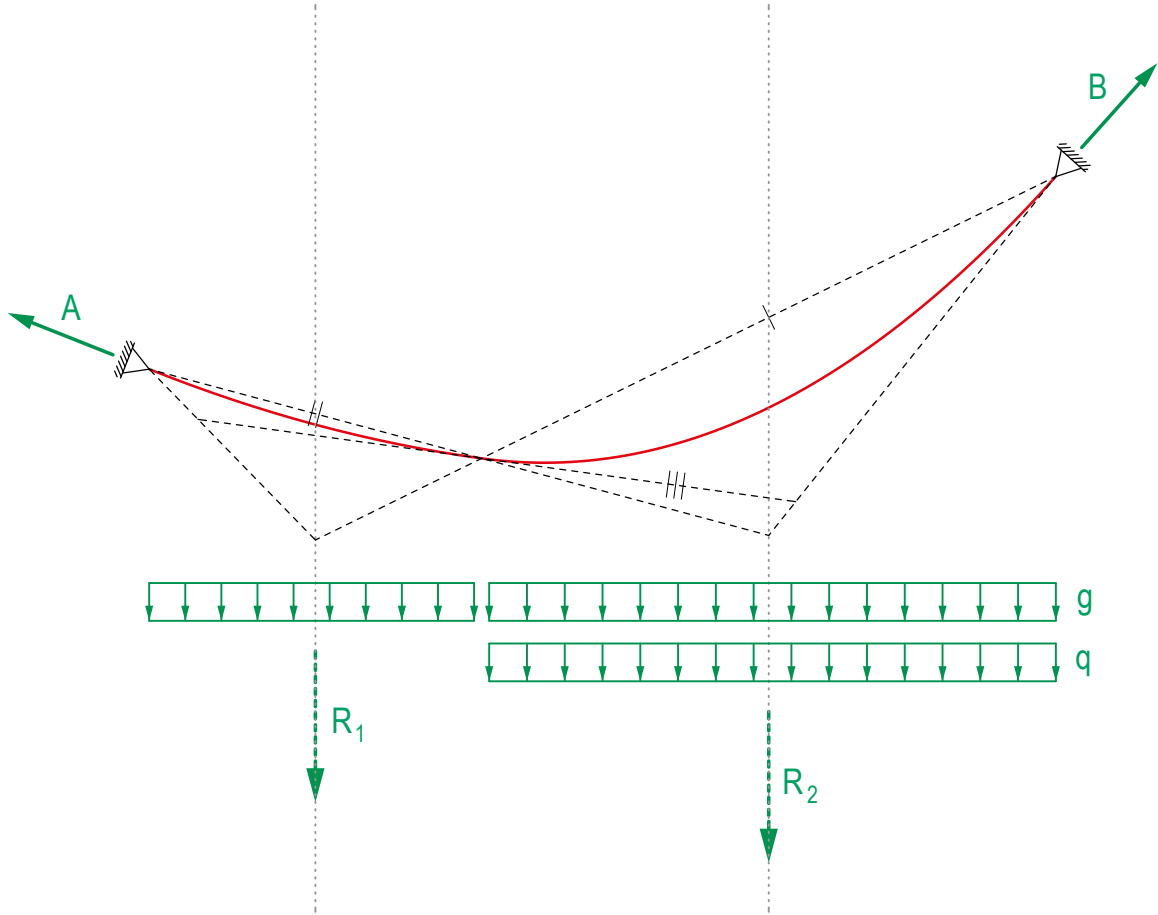

Lageplan 1:100  
*Form diagram 1:100*

Kräfteplan 1 cm  $\cong$  1 kN  
*Force diagram 1 cm  $\cong$  1 kN*



*Stiffening using a truss*

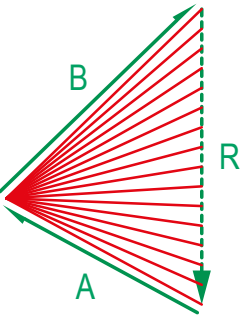
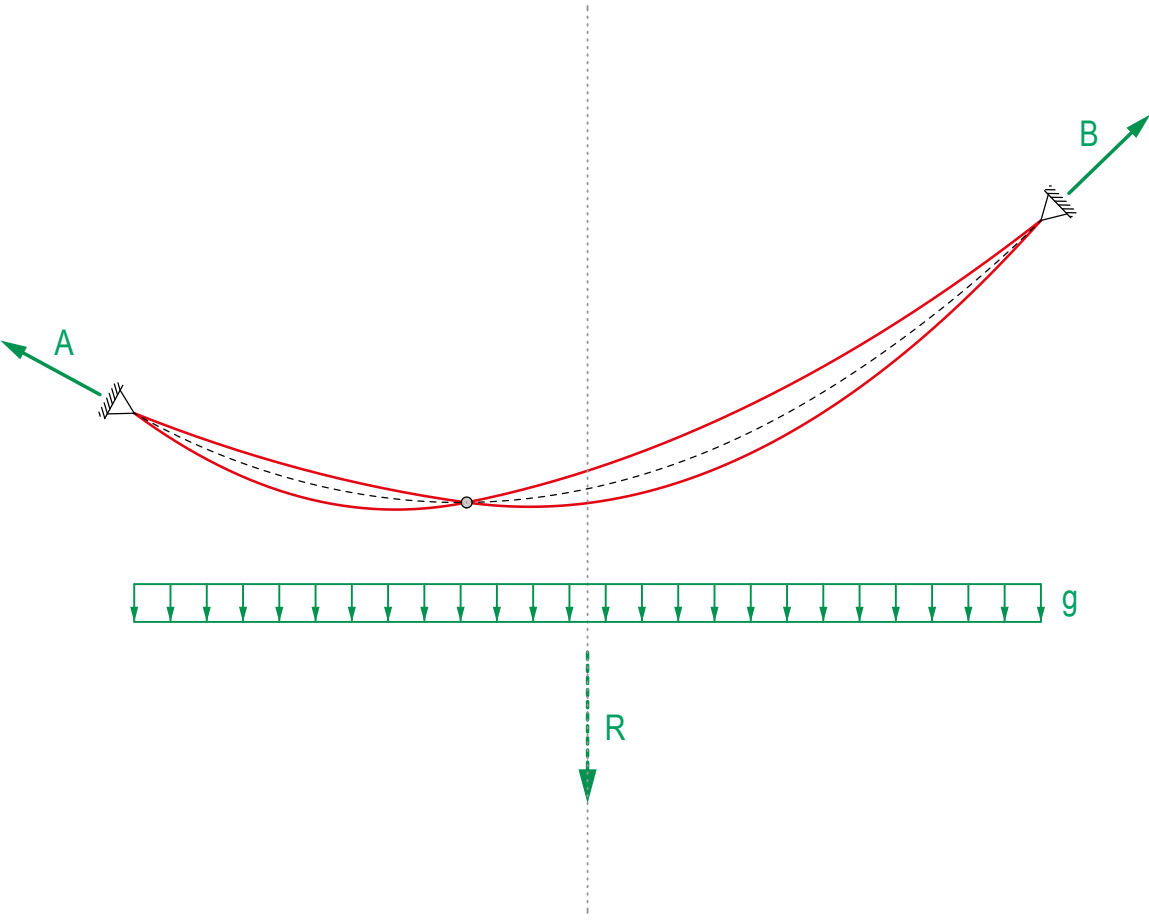

Lageplan 1:100  
*Form diagram 1:100*

Kräfteplan 1 cm  $\cong$  1 kN  
*Force diagram 1 cm  $\cong$  1 kN*

eQ: Cable for non-uniformly distributed load

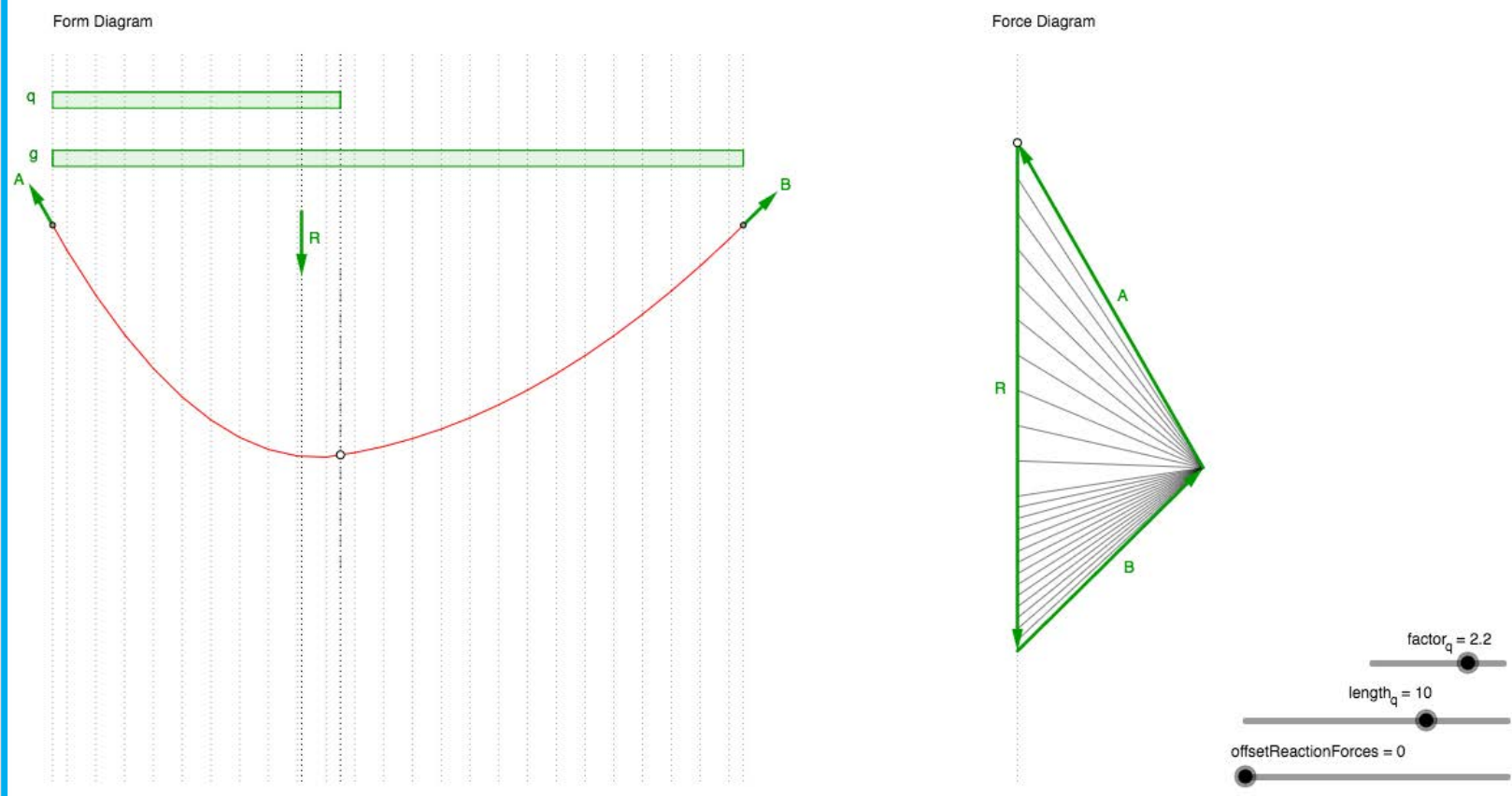

<http://www.block.arch.ethz.ch/eq/drawing/view/15>

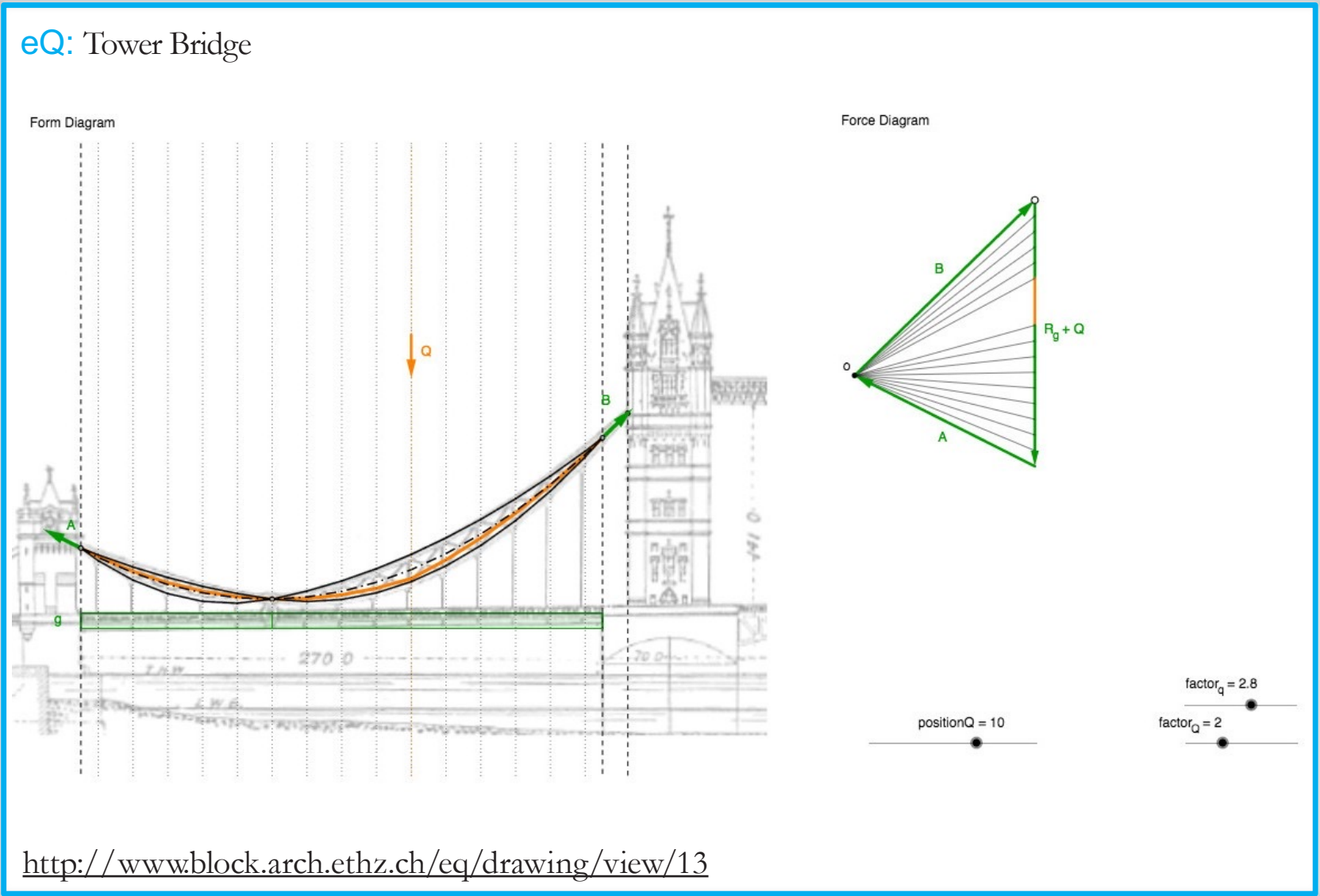

# Seile

## *Cables*

Tragwirkung eines Seils unter mehreren beliebigen Lasten

*A cable's reaction to a set of non-concurrent loads*

Tragwirkung eines Seils unter gleichmässig verteilter Belastung

*A cable's reaction to uniformly distributed loads*

Fallstudie: Golden Gate Brücke

*Case study: Golden Gate bridge*

Formänderung von Seiltragwerken

*Form-active behaviour of cables*

Aussteifung durch Erhöhung der Eigenlasten

*Stiffening by increasing dead loads*

Aussteifung durch Vorspannung

*Stiffening through prestressing*

Aussteifung mittels eines Fachwerks

*Stiffening using a truss*

>> Übersicht der Aussteifungssysteme

*Overview of stiffening schemes*

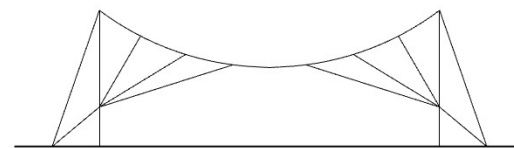
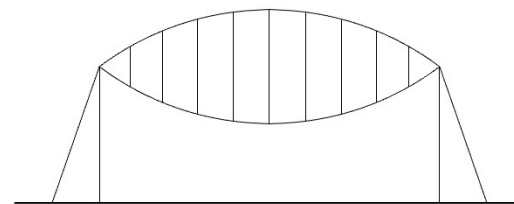
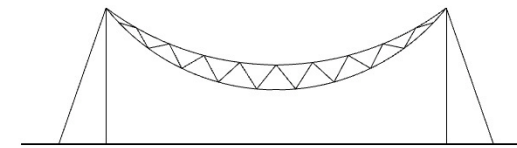
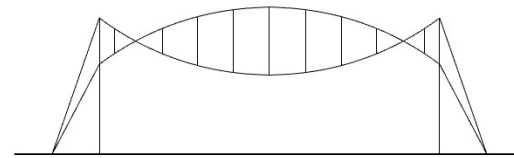
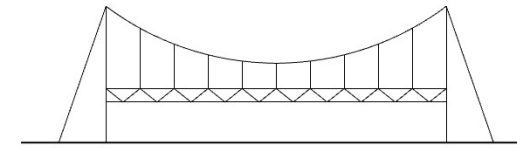
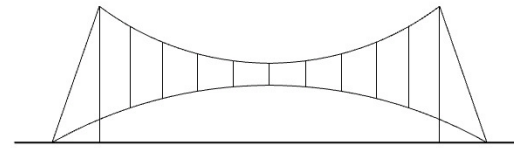
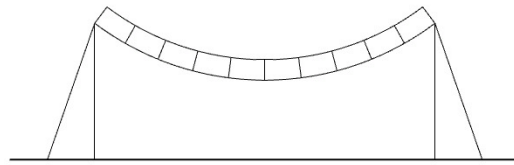

Aussteifung durch Erhöhung der Eigenlasten  
*Stiffening by increasing dead loads*

Aussteifung durch Vorspannung  
*Stiffening through prestressing*

Aussteifung mittels eines Fachwerks  
*Stiffening using a truss*



# Seilnetz- und Membranstrukturen

## *Cable-net and membrane structures*

>> Tragwirkung von Seilnetz- und Membranstrukturen  
*Static behaviour of cable-net and membrane structures*

Frei Ottos physische Formfindungs-Experimente  
*Frei Otto's physical form-finding experiments*

Arten von gespannten Dachkonstruktionen  
*Types of tensioned roof systems*

Pneumatische Membranstrukturen  
*Pneumatic membrane structures*

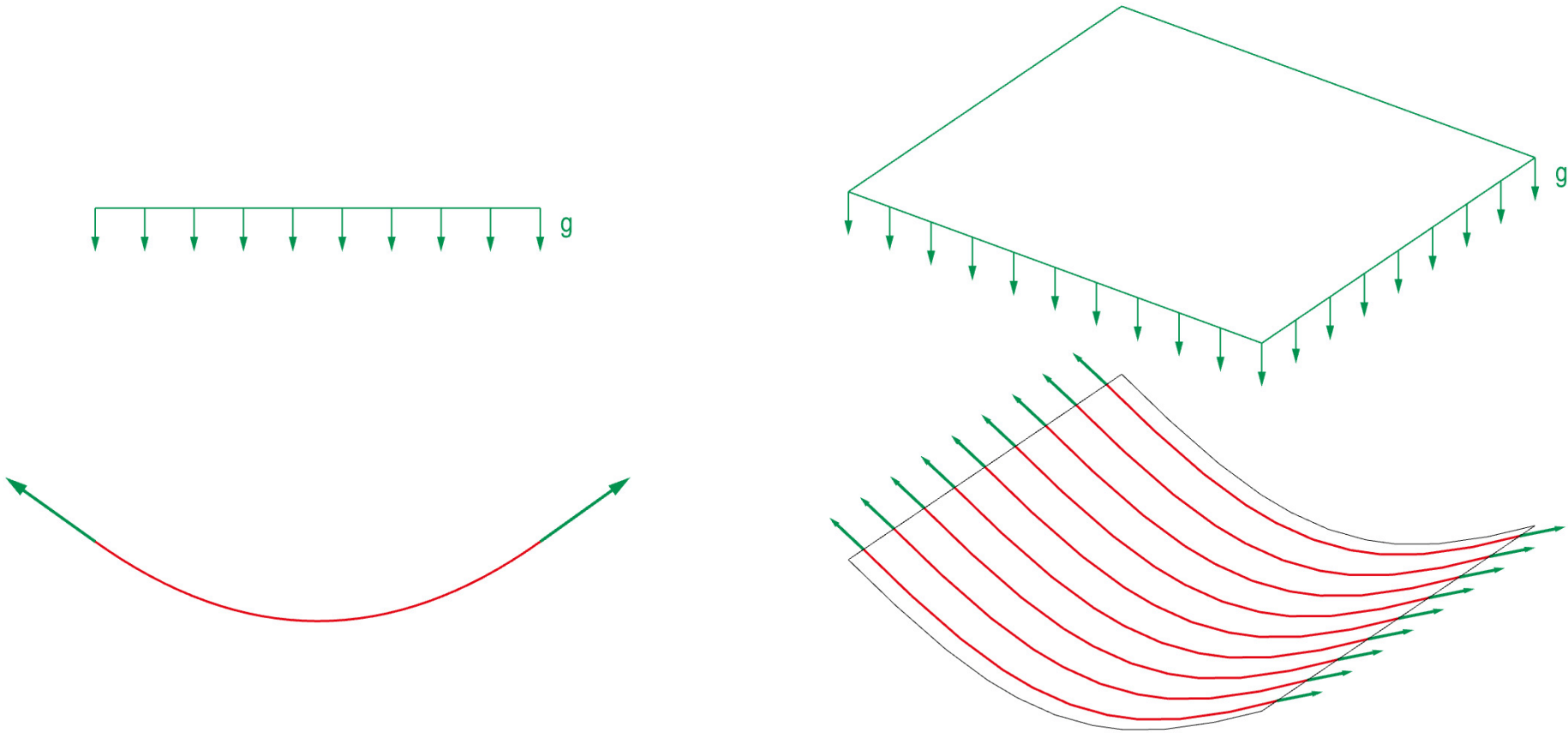



Eero Saarinen, Ammann & Whitney: Dulles Airport, Virginia, 1962

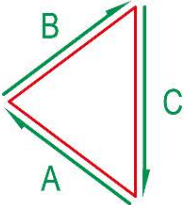
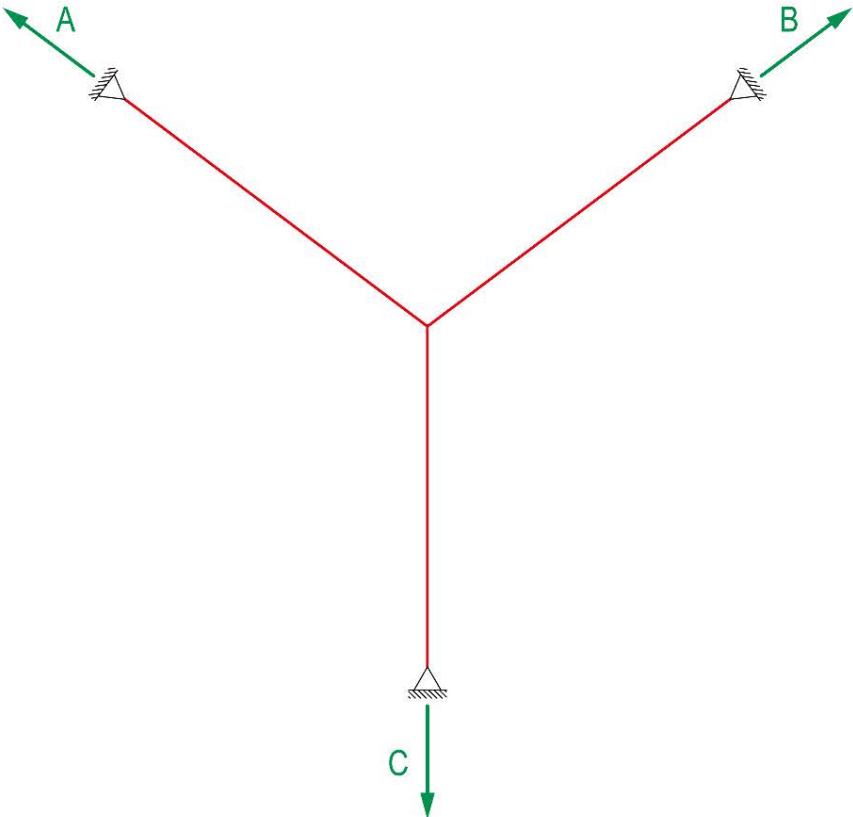

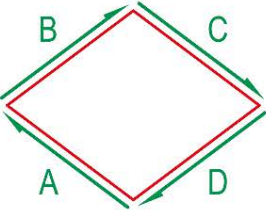
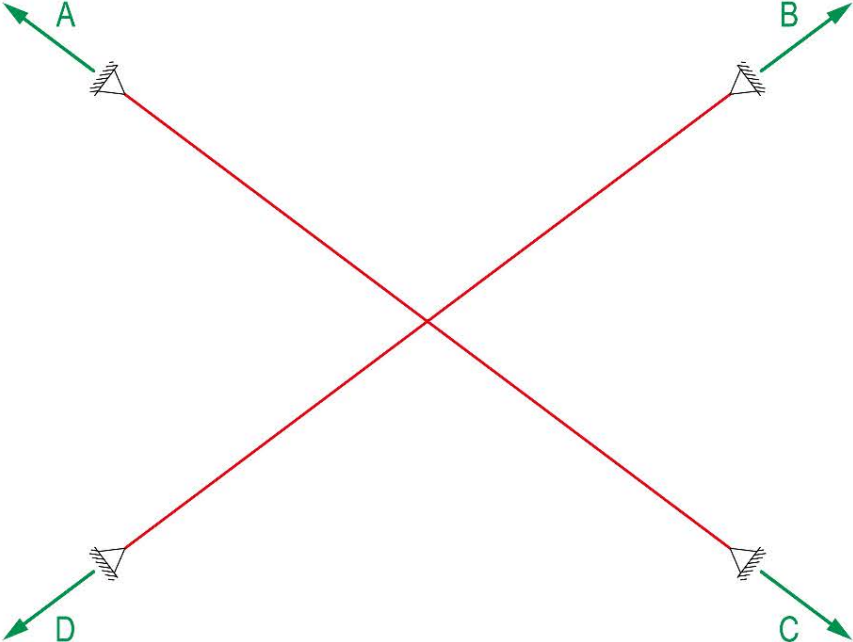



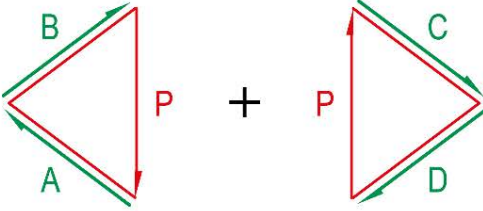
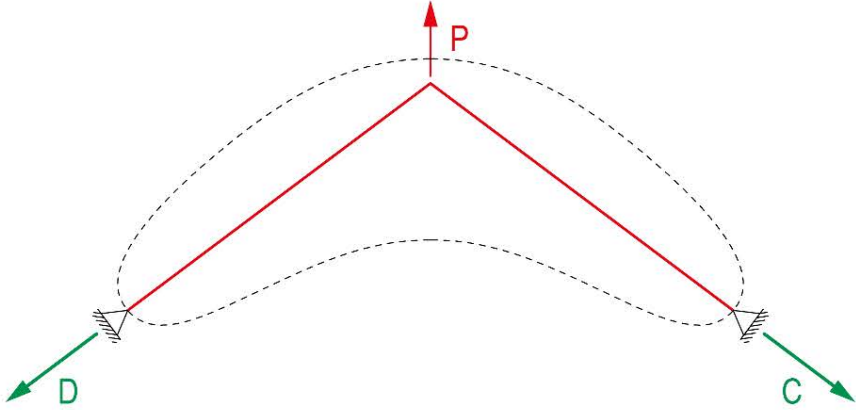
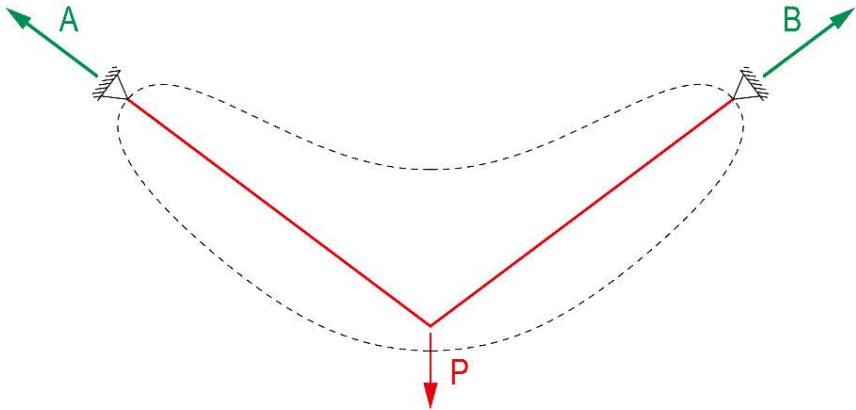

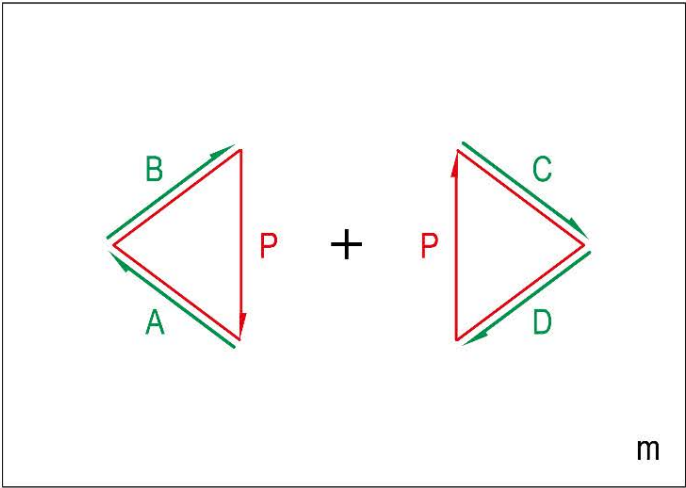
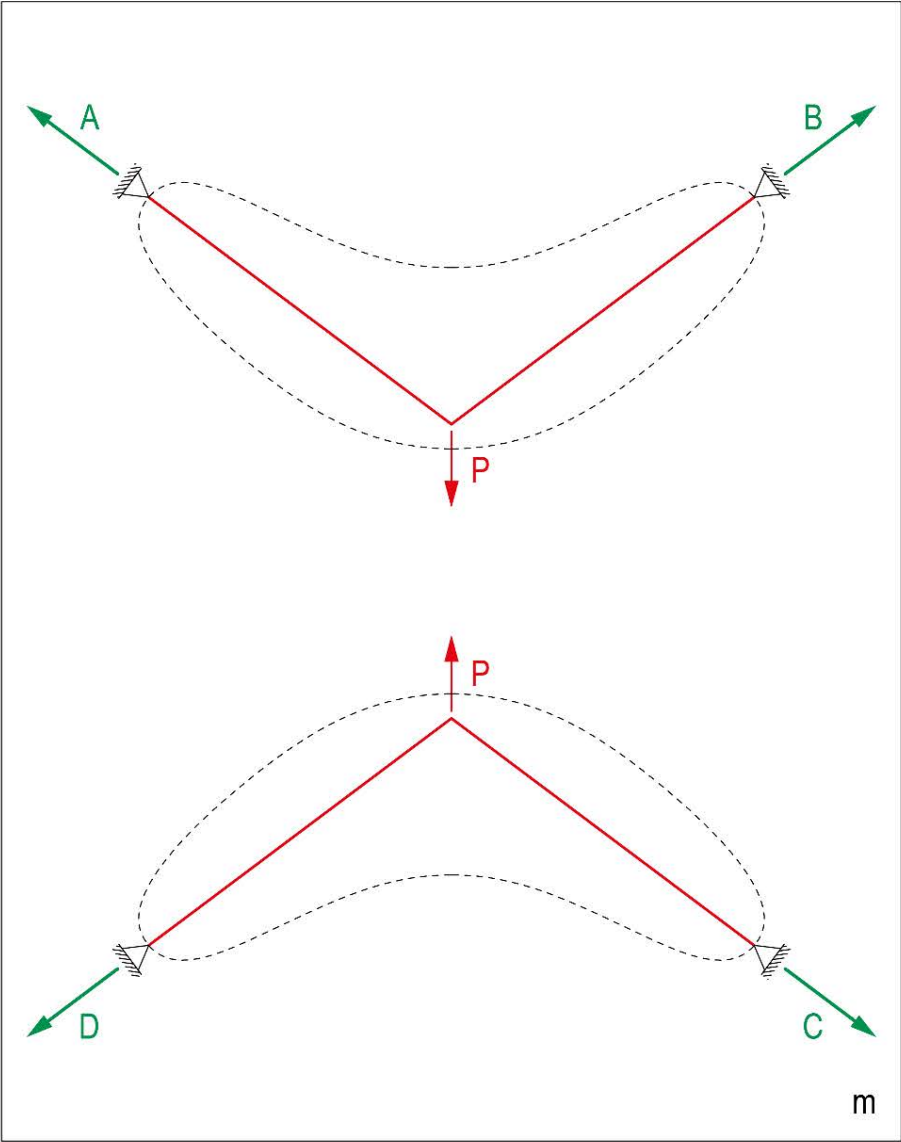

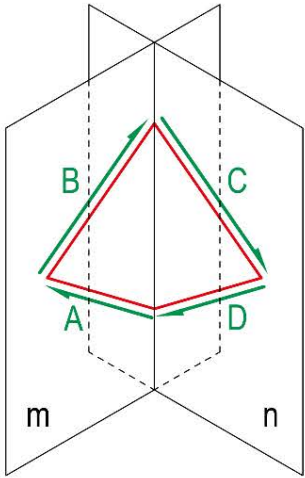
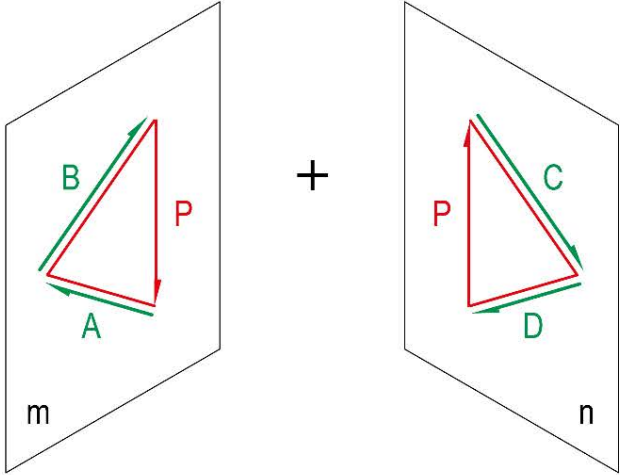
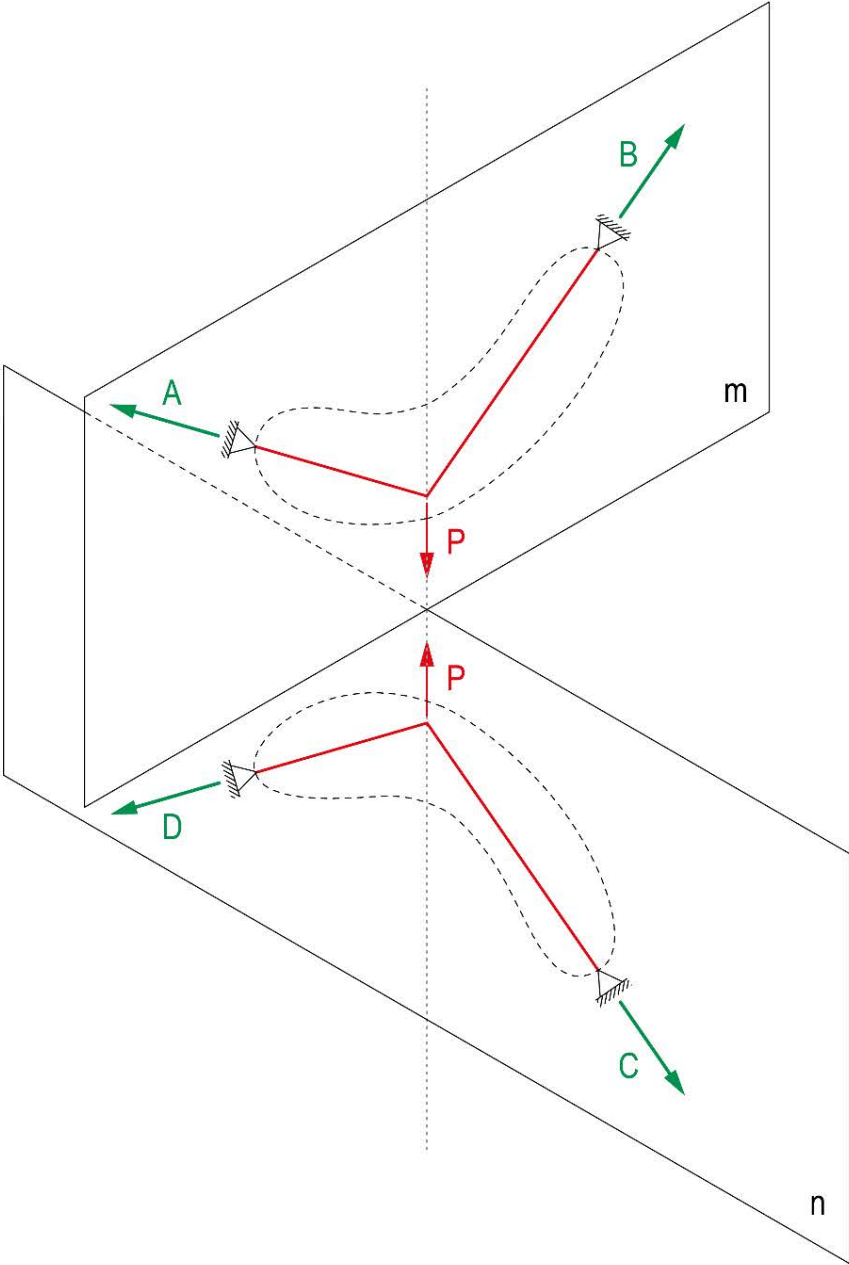

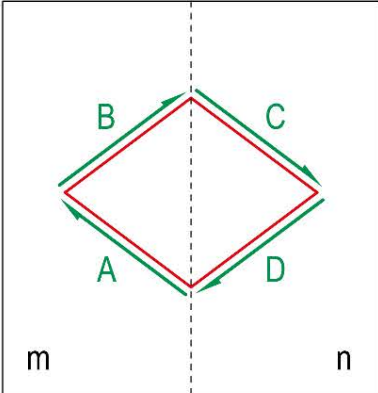
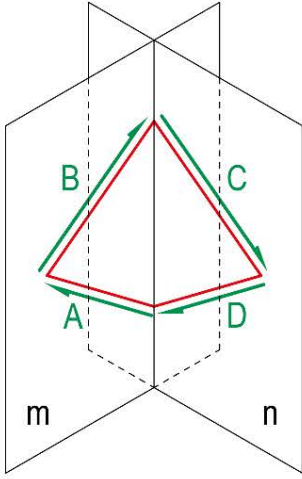
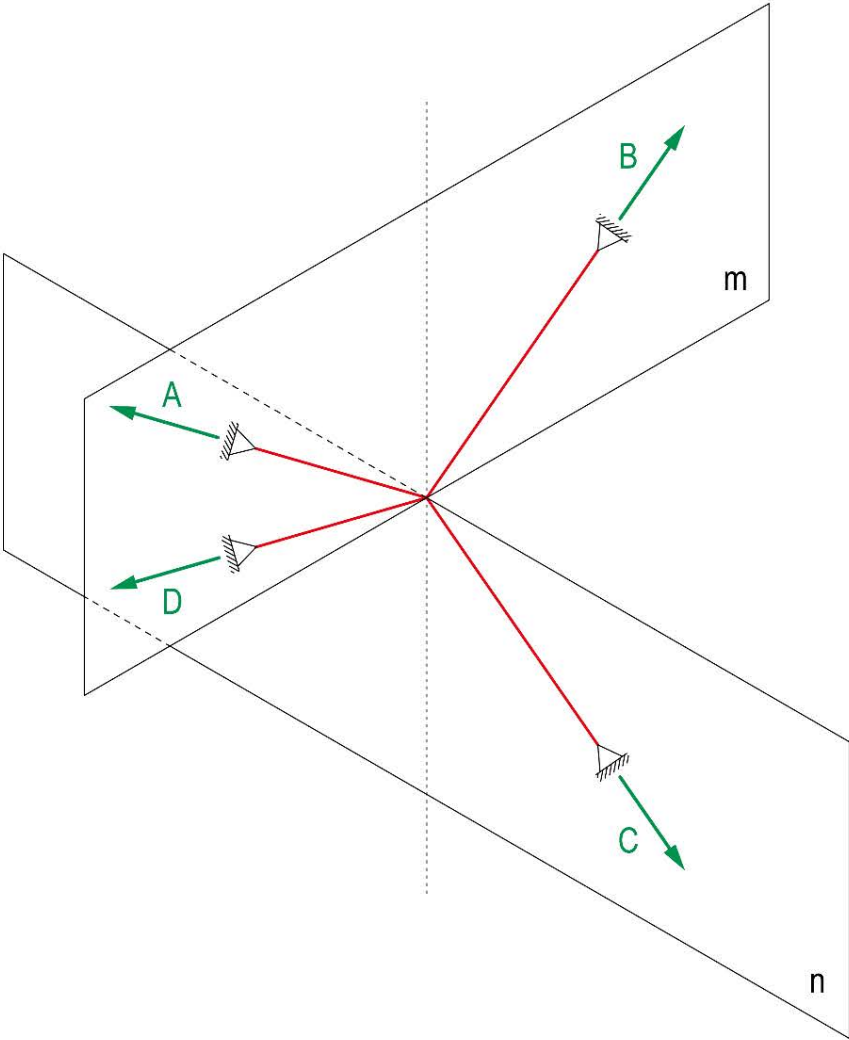

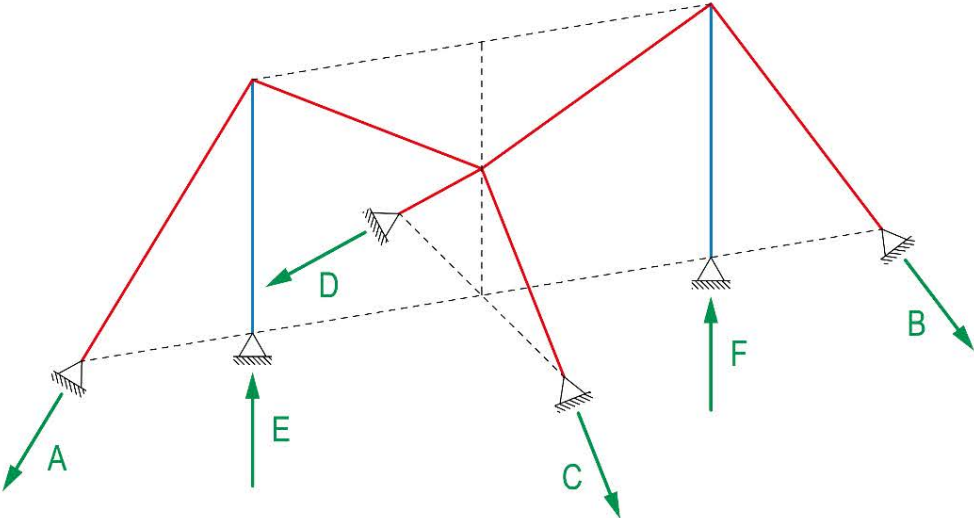
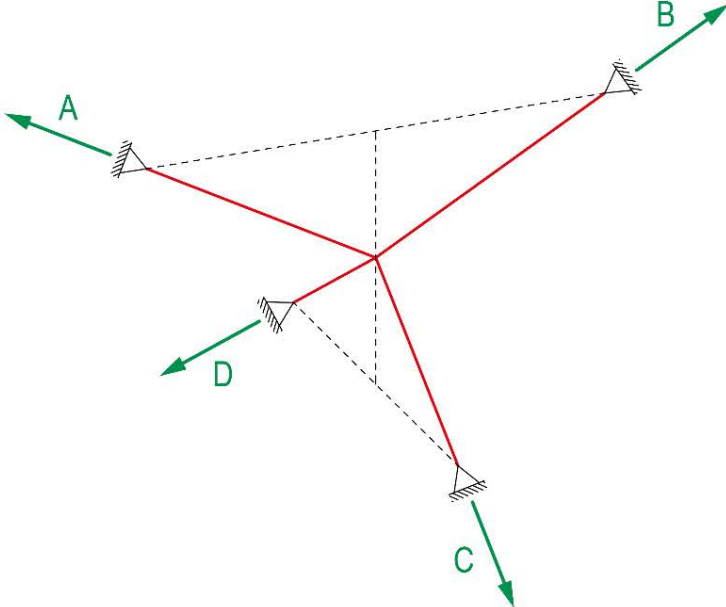



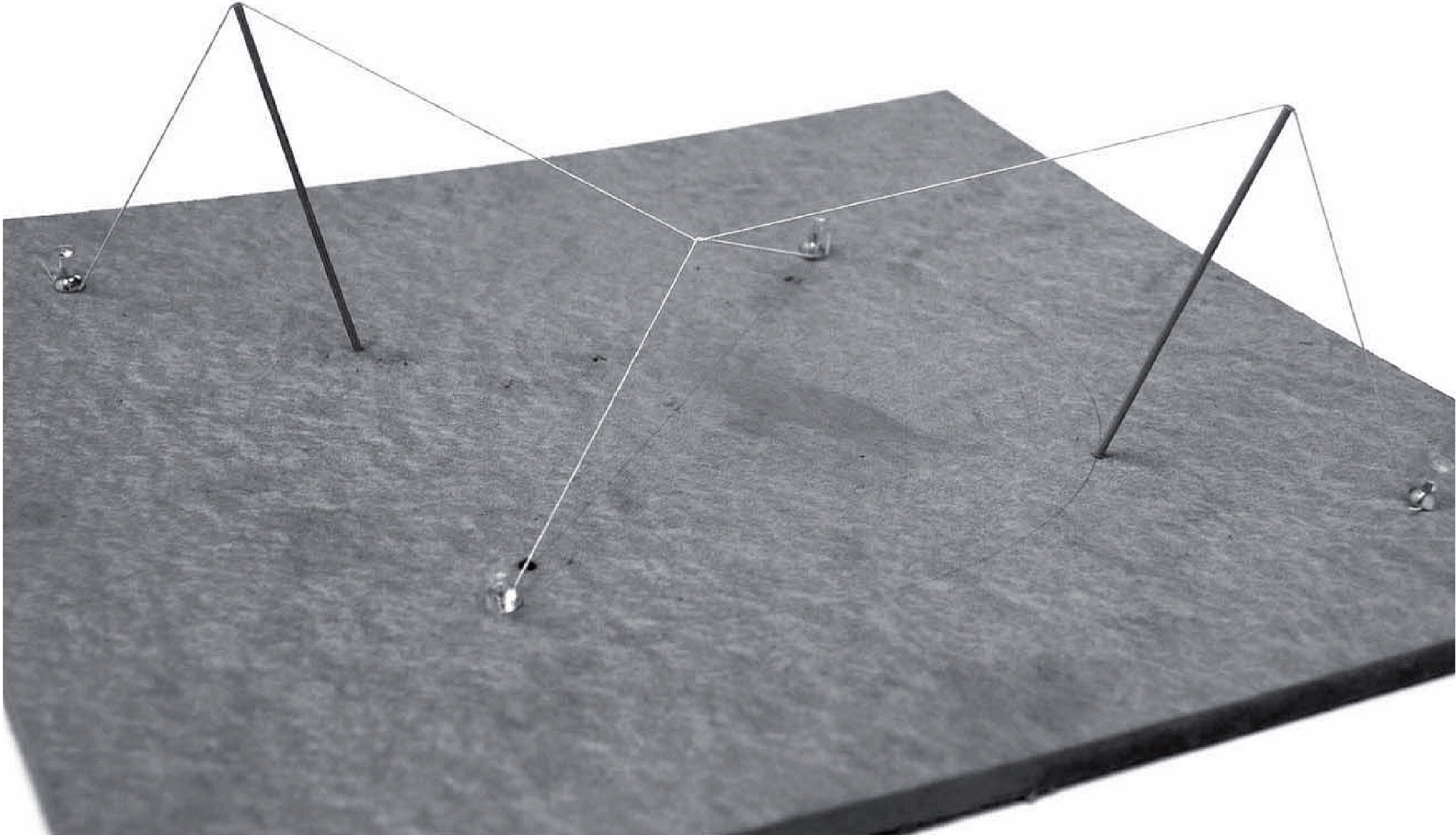

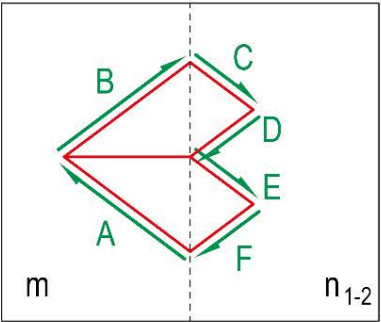
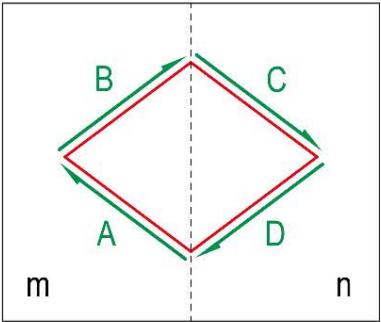
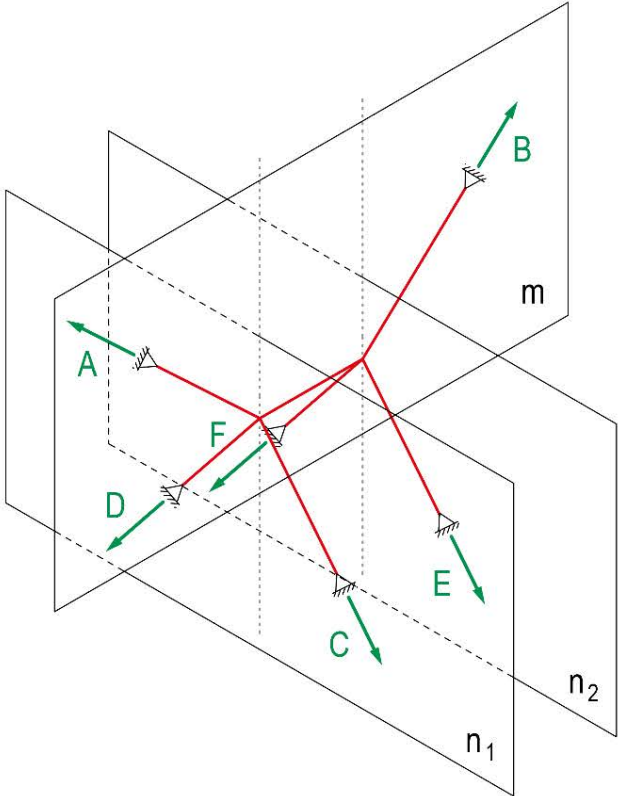
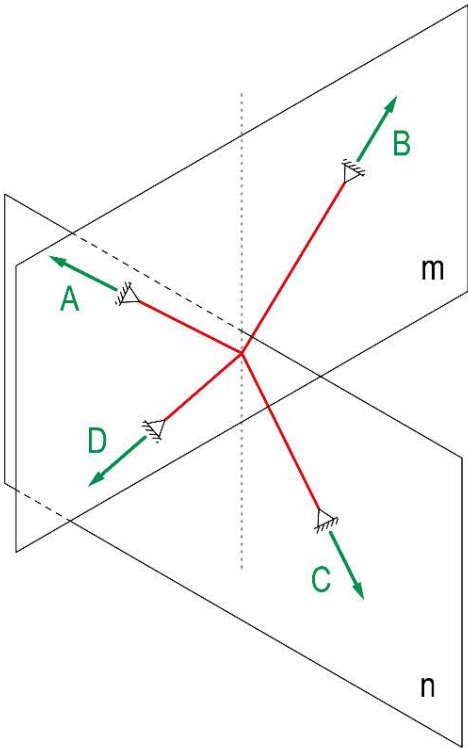

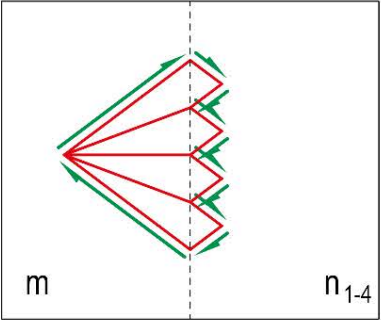
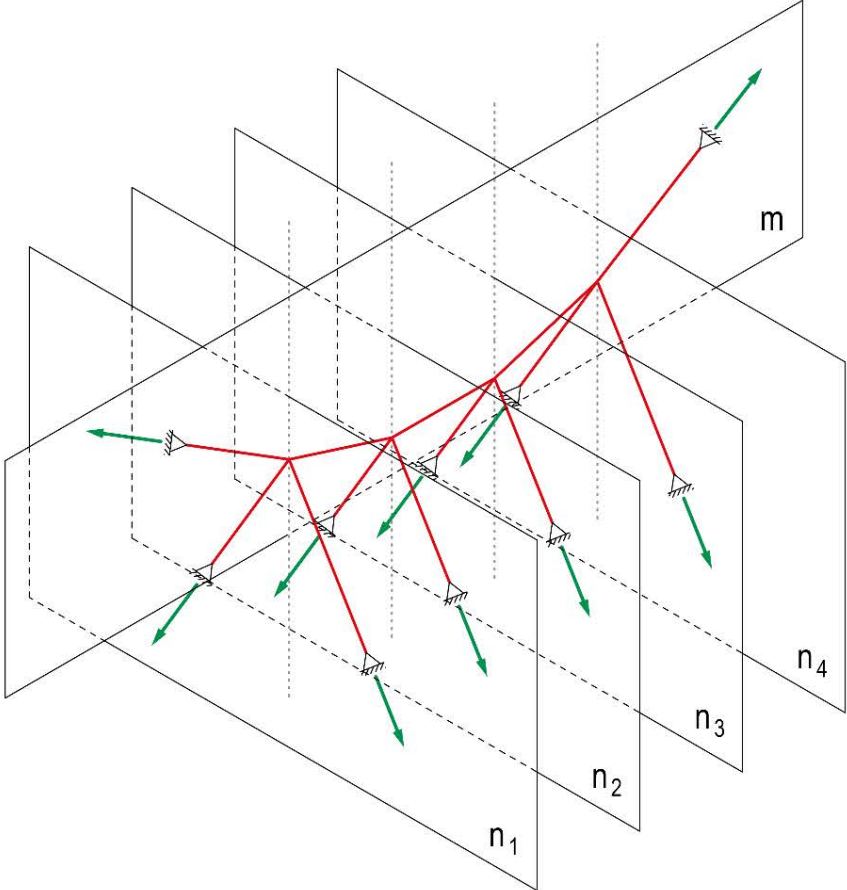
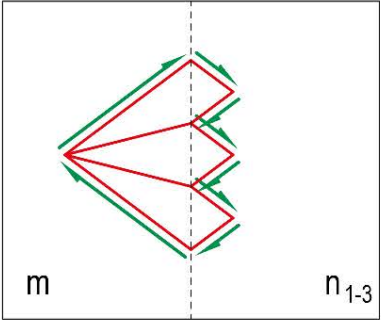
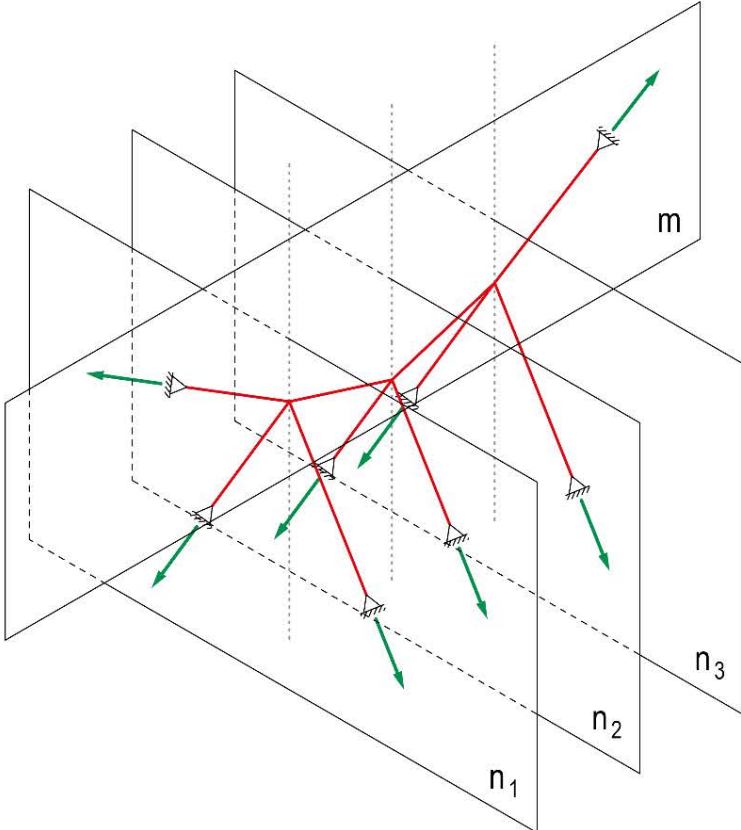

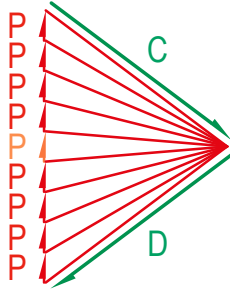
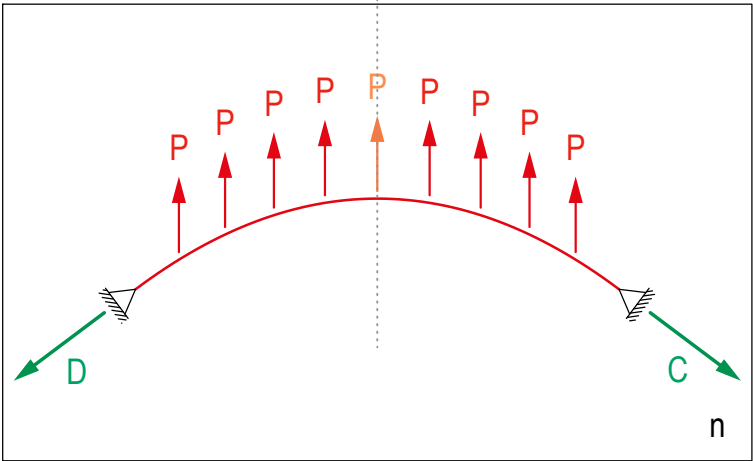
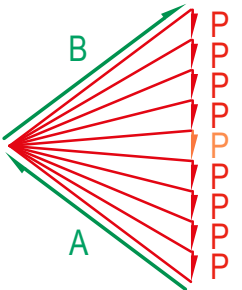
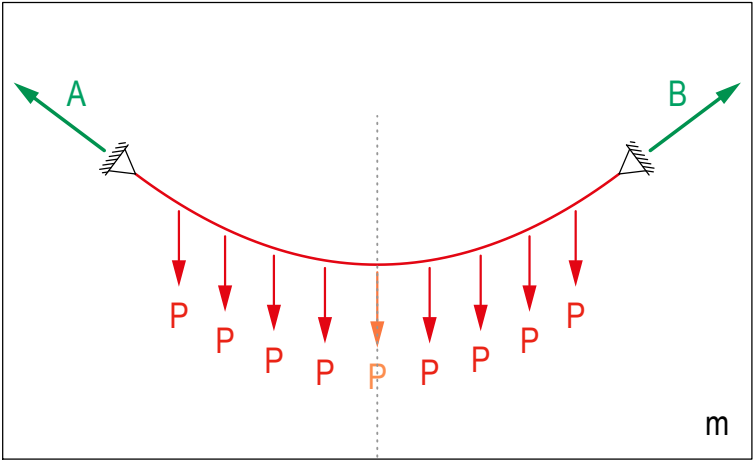
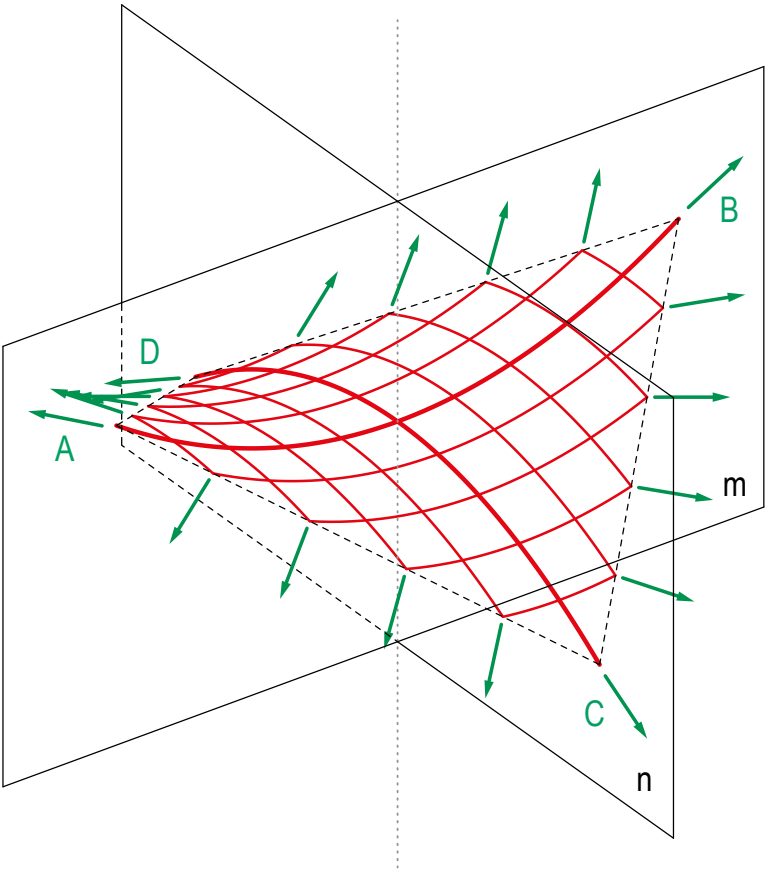



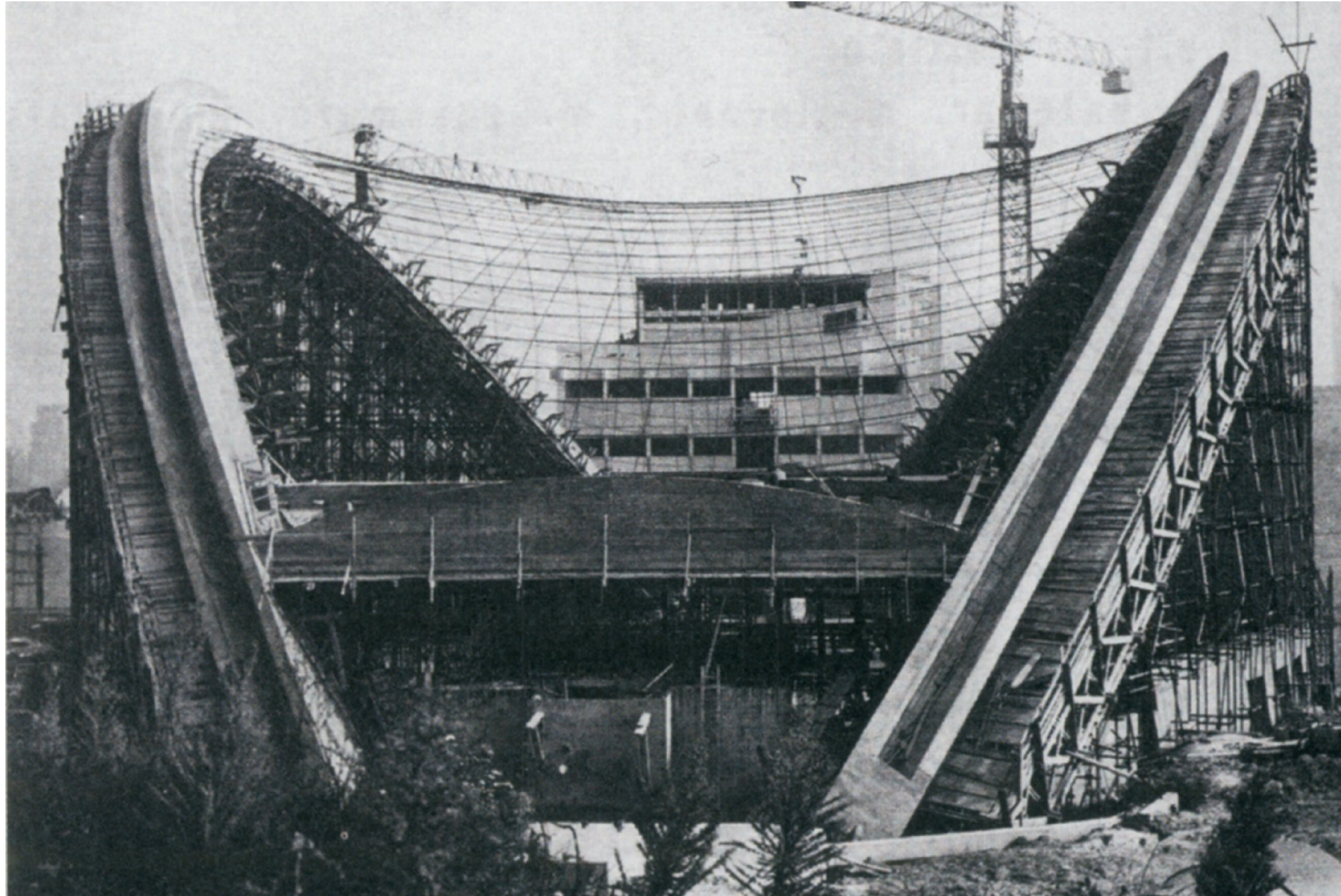

Anatole Kopp, R. Sager: Stade de Saint-Ouen, Nanterre, 1971



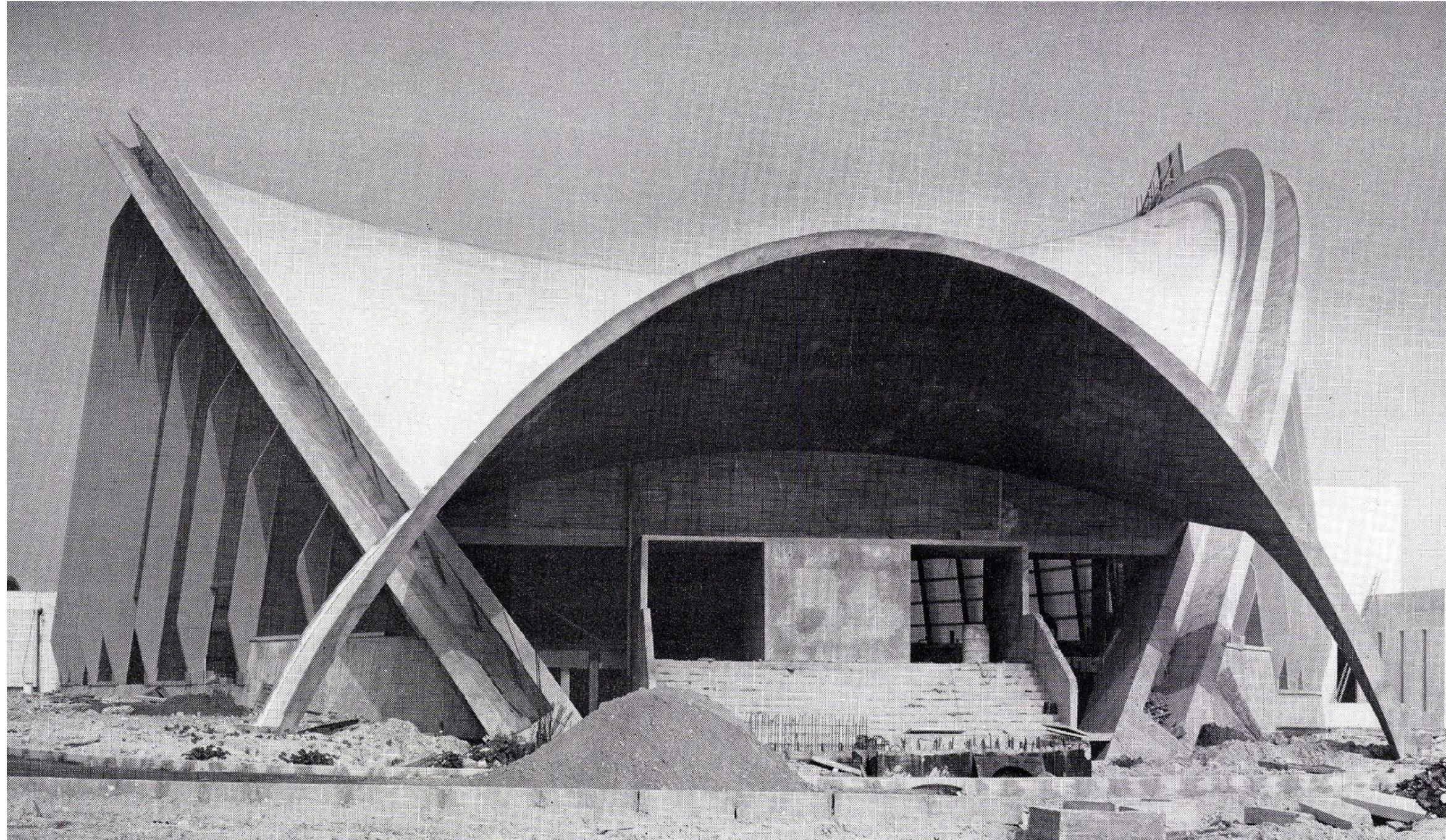

Anatole Kopp, R. Sager: Stade de Saint-Ouen, Nanterre, 1971





Anatole Kopp, R. Sager: Stade de Saint-Ouen, Nanterre, 1971

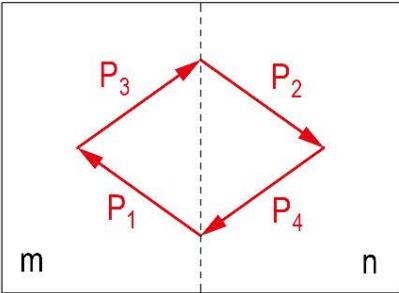
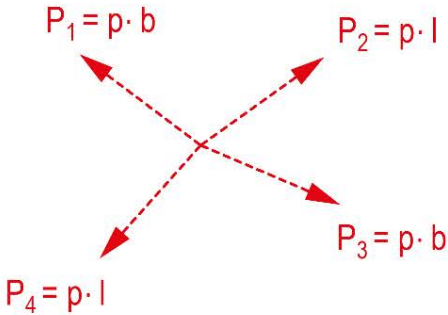
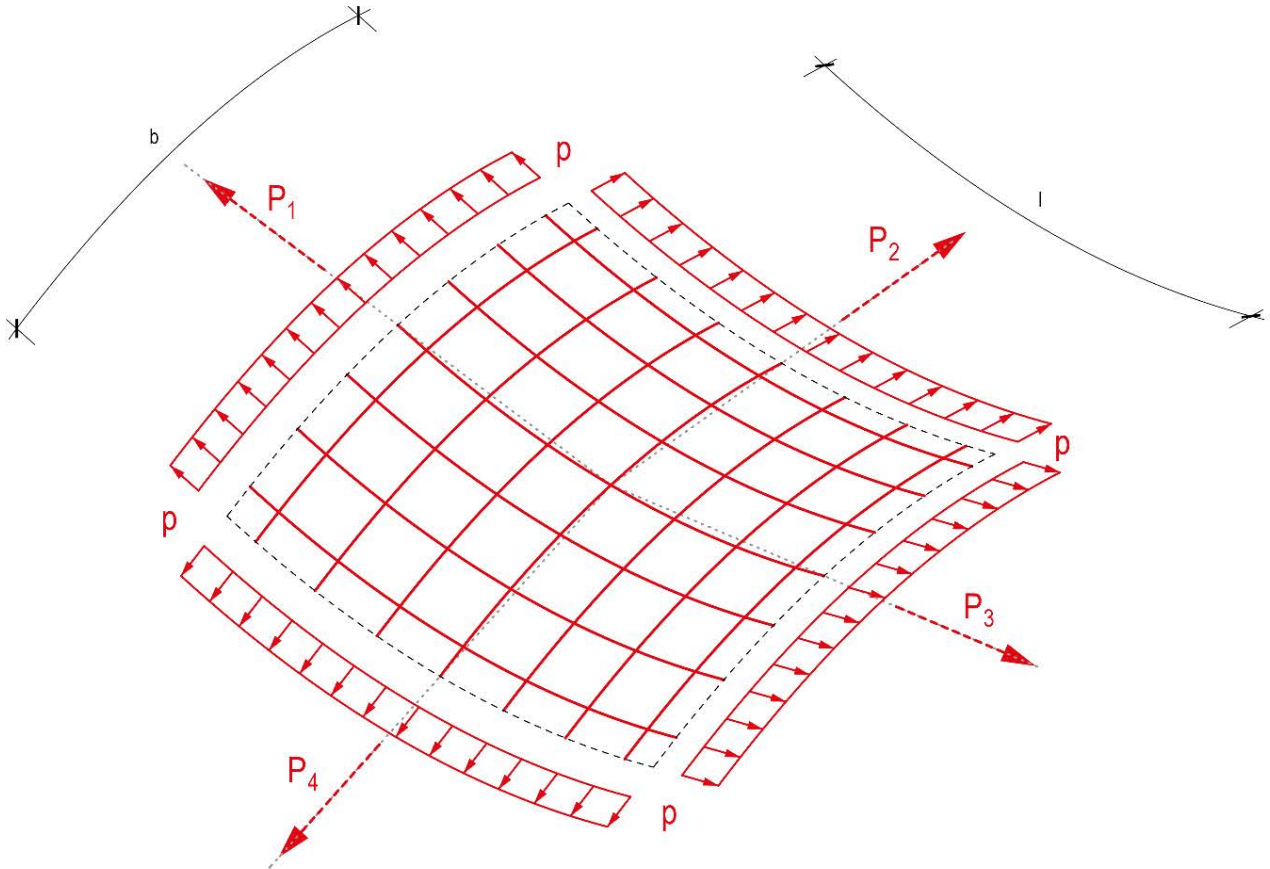

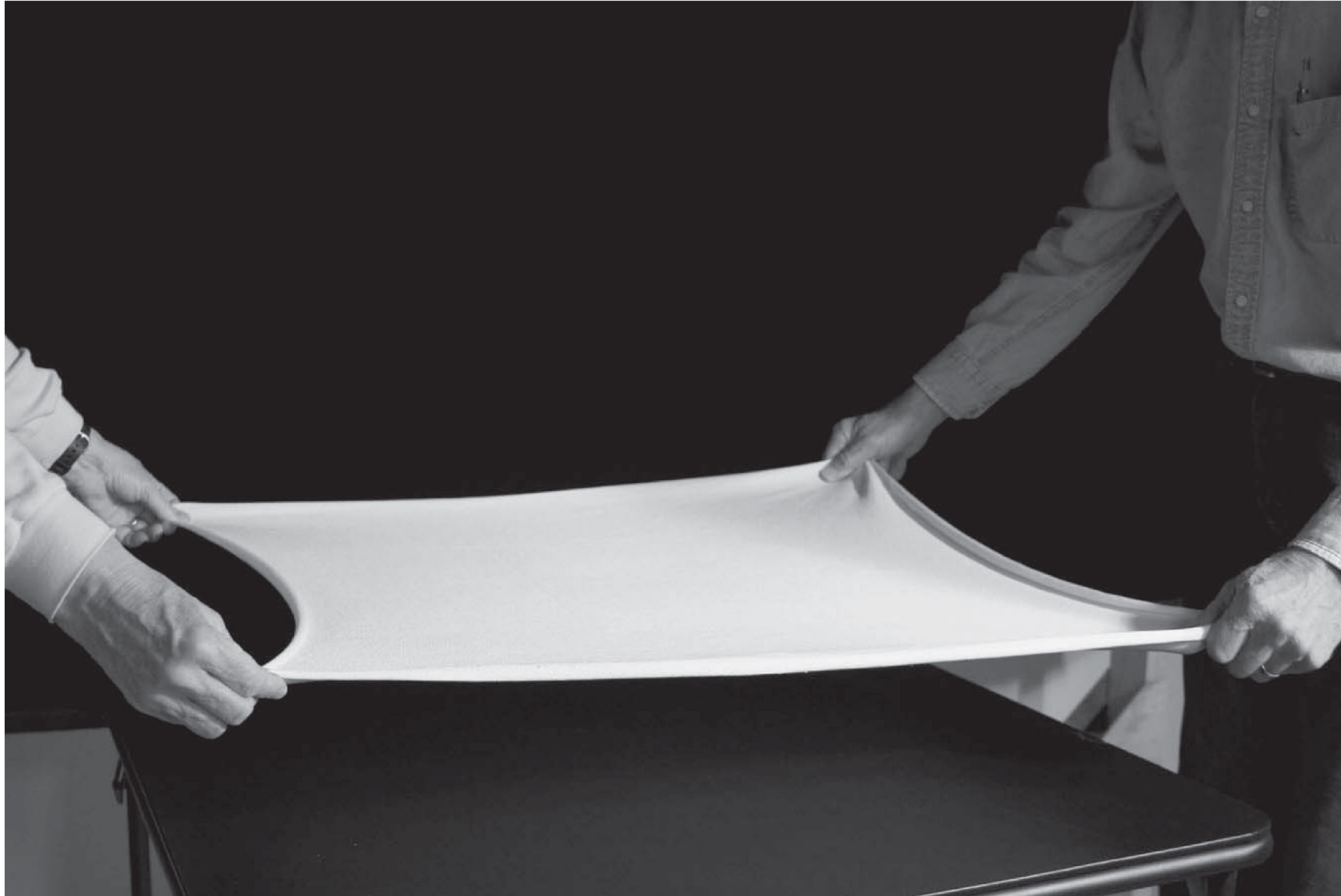



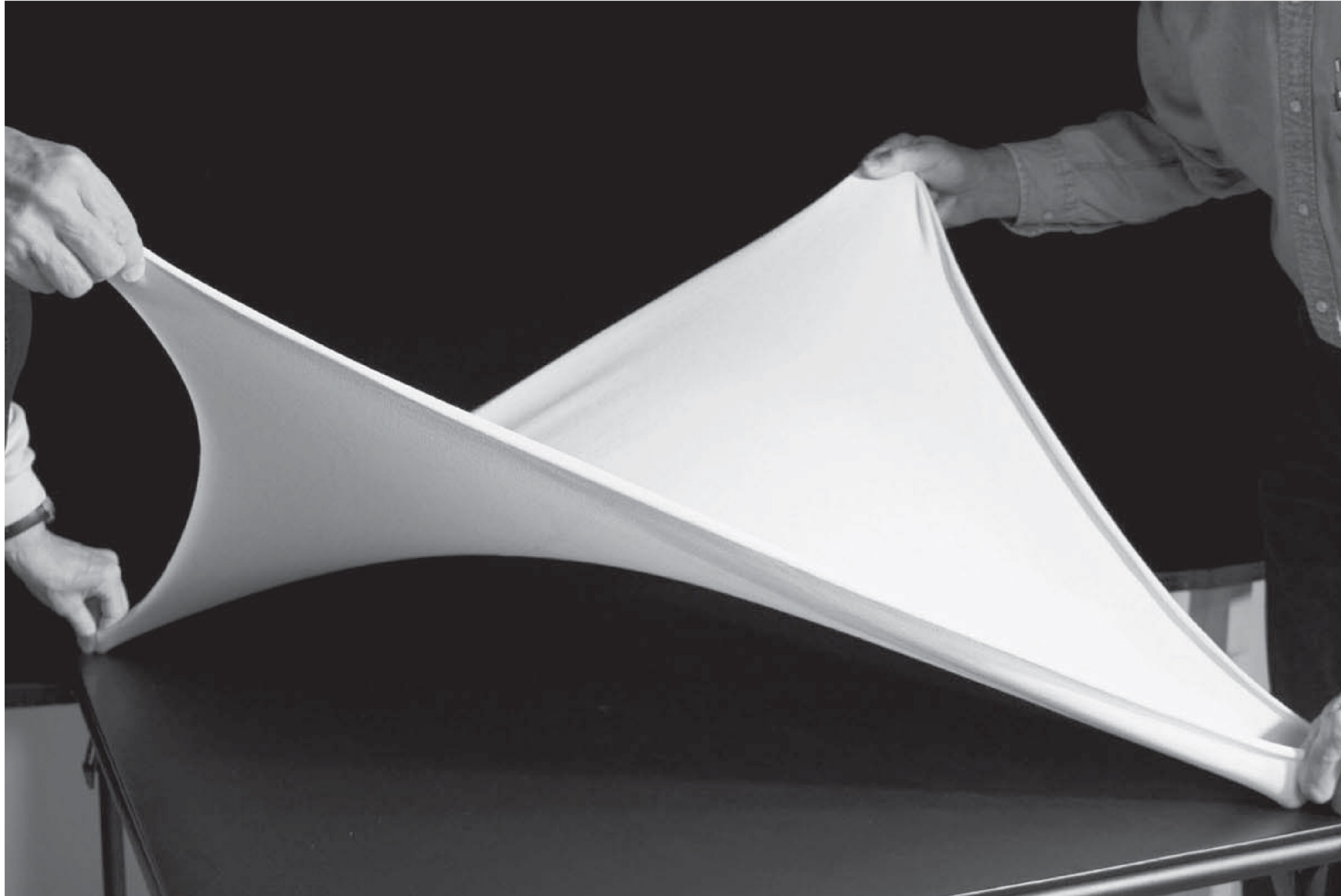



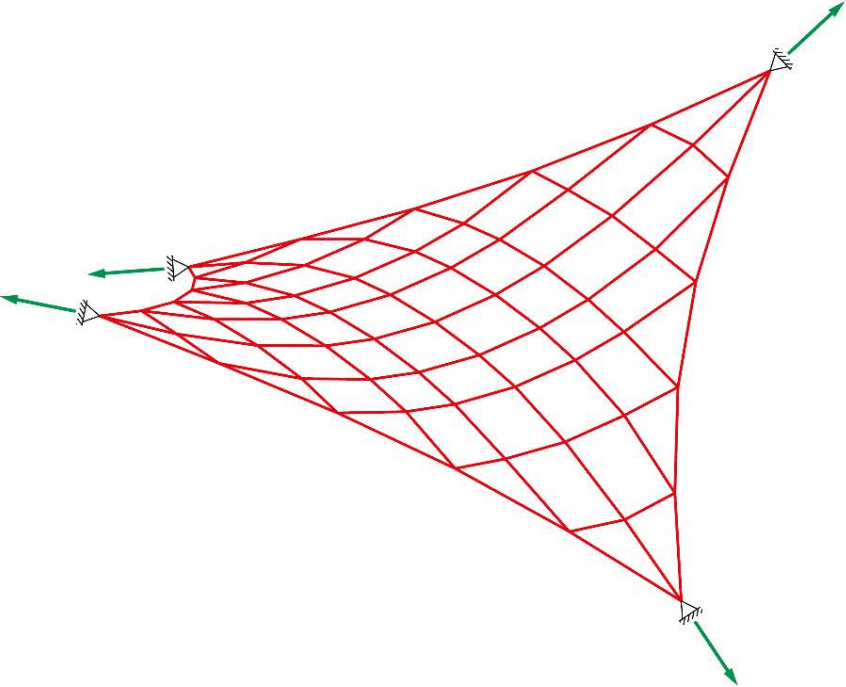
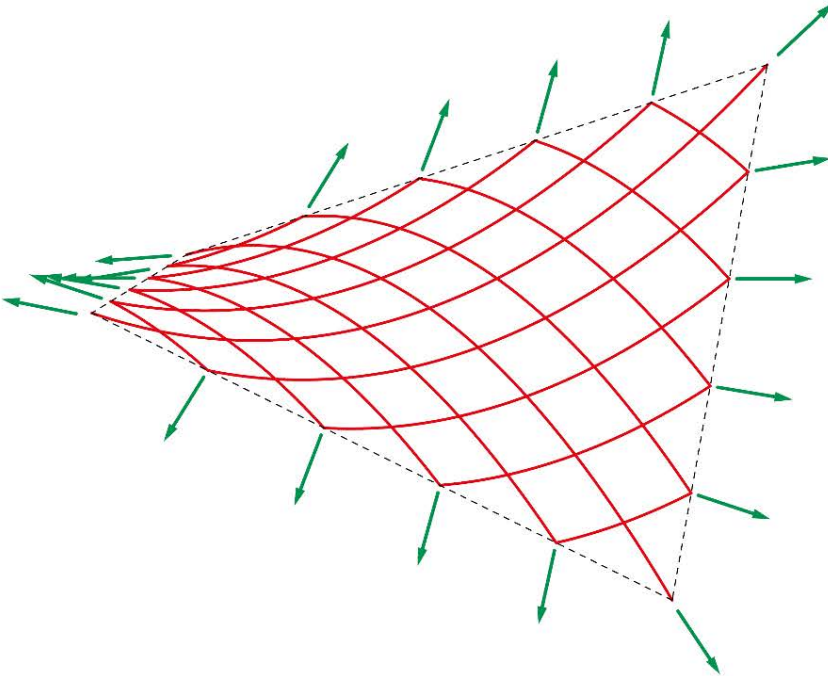

# Seilnetz- und Membranstrukturen

## *Cable-net and membrane structures*

Tragwirkung von Seilnetz- und Membranstrukturen

*Static behaviour of cable-net and membrane structures*

>>

Frei Ottos physische Formfindungs-Experimente

*Frei Otto's physical form-finding experiments*

Arten von gespannten Dachkonstruktionen

*Types of tensioned roof systems*

Pneumatische Membranstrukturen

*Pneumatic membrane structures*





Frei Otto, Pritzker Preisträger 2015



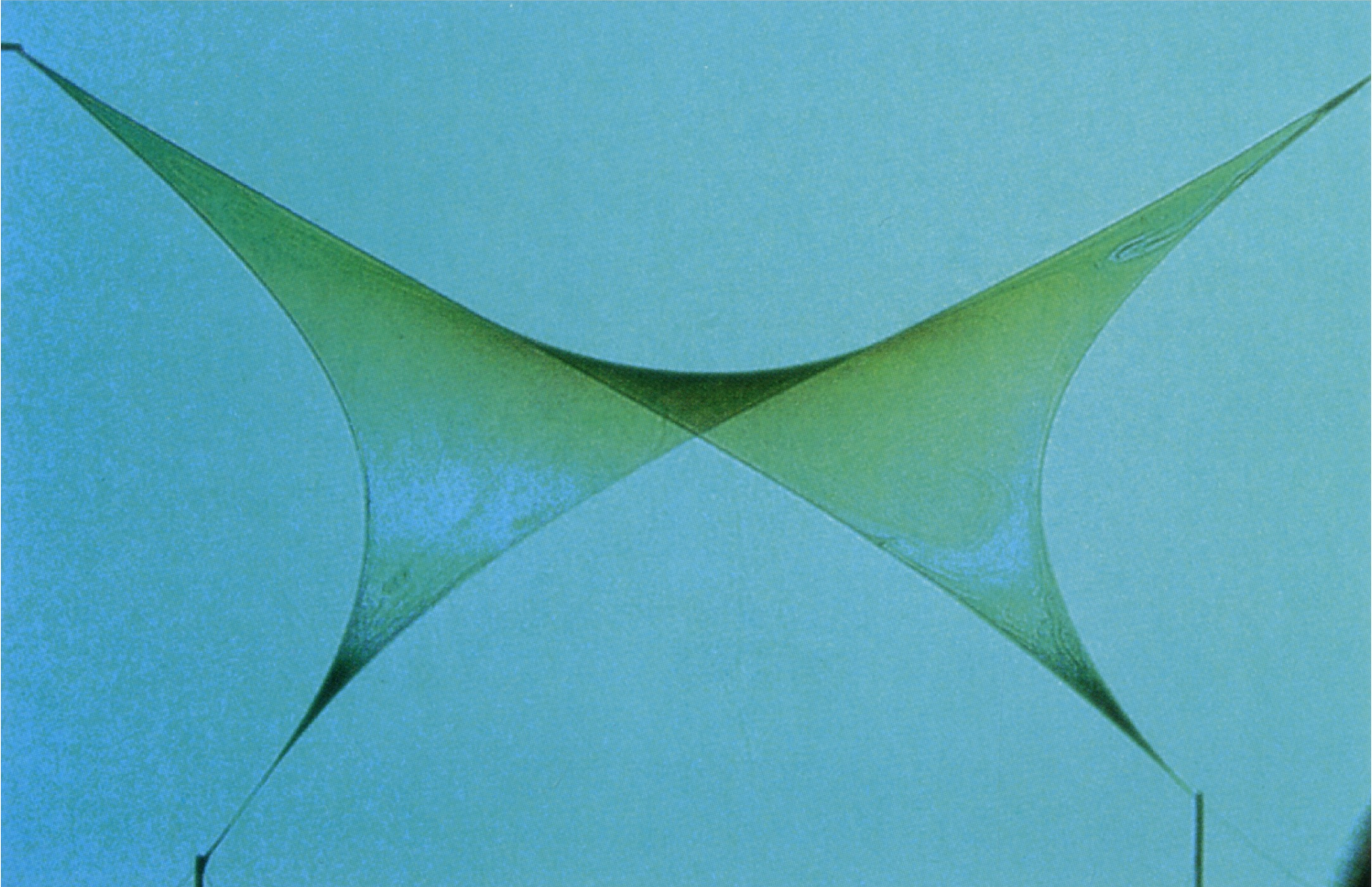



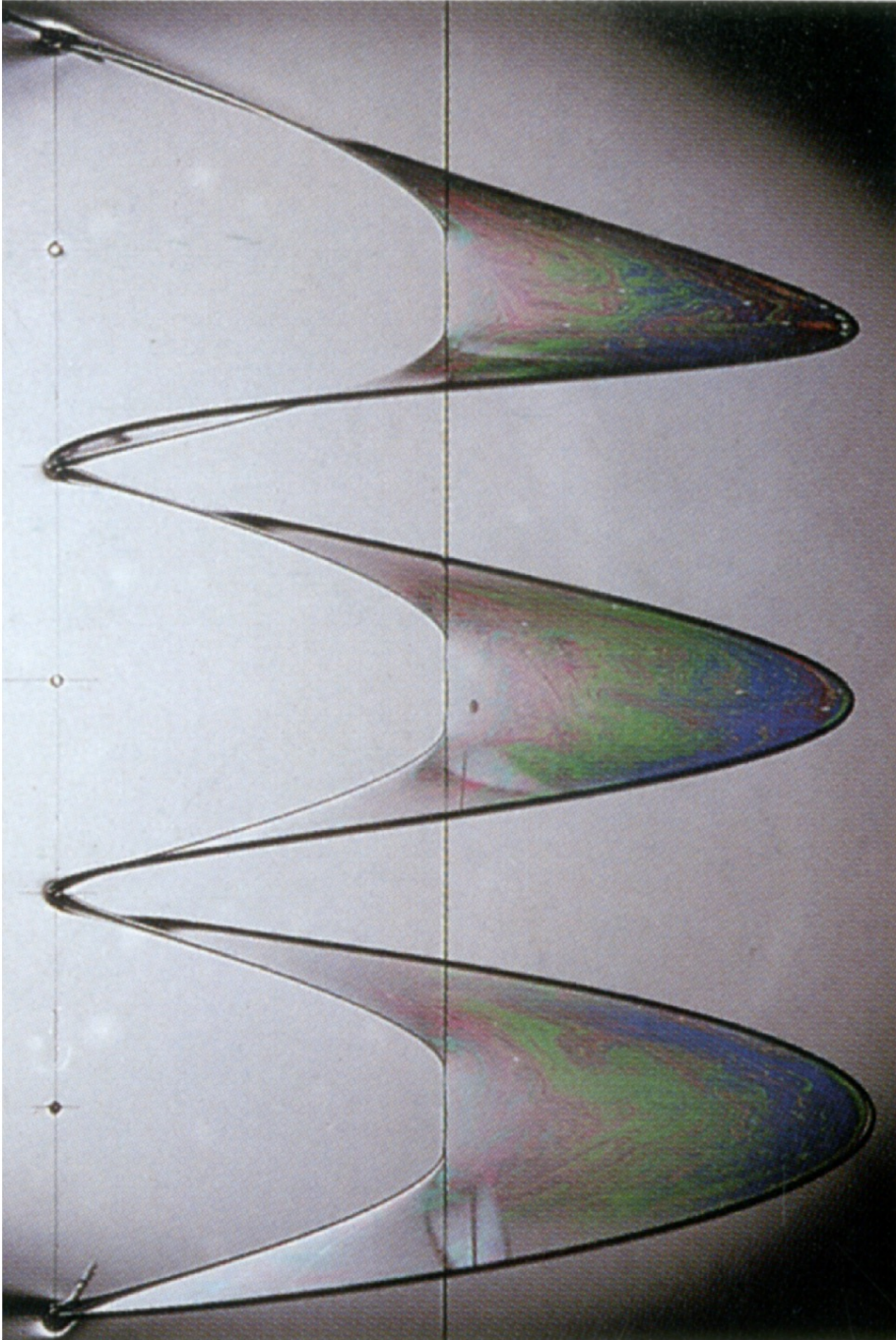



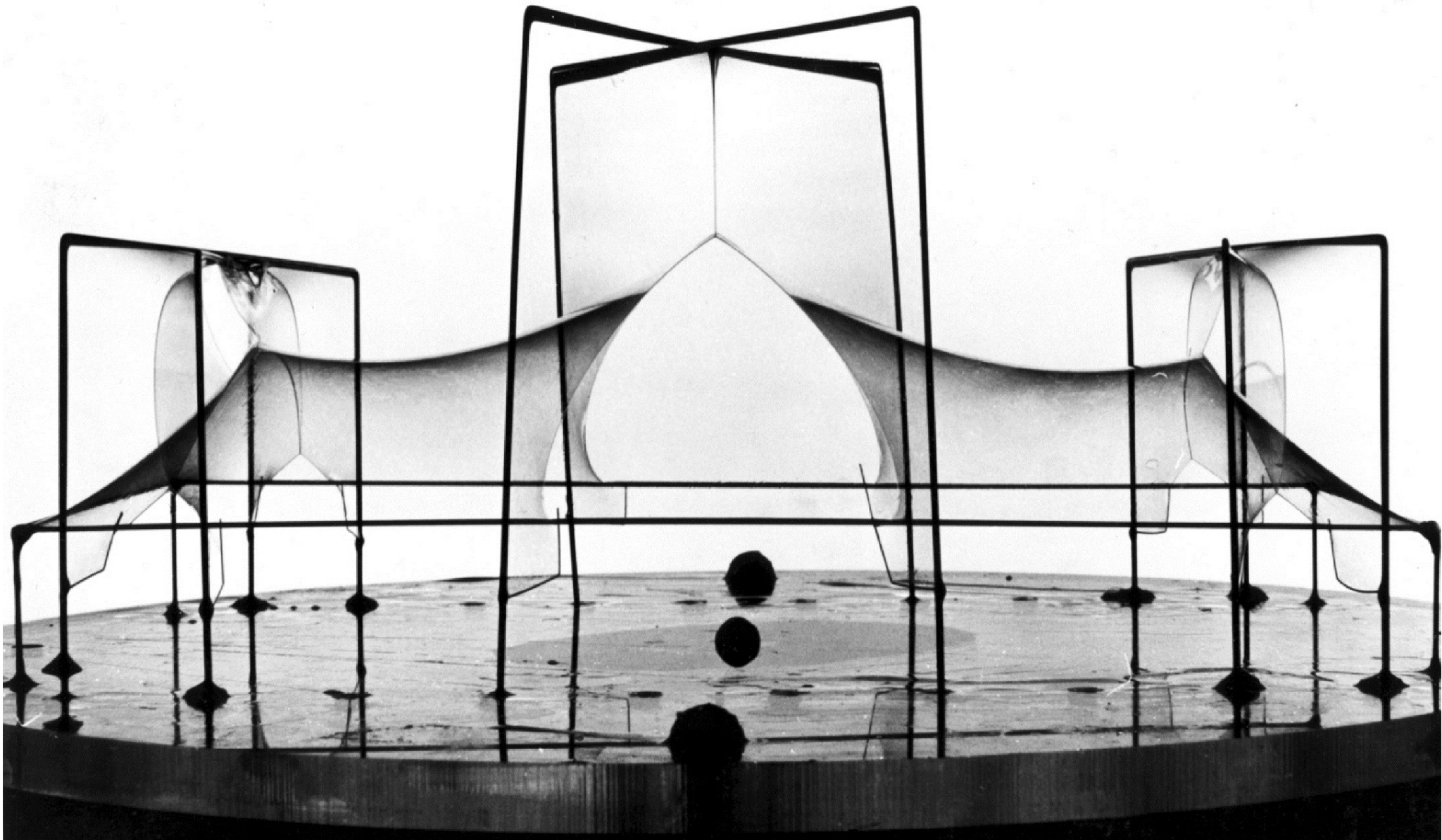

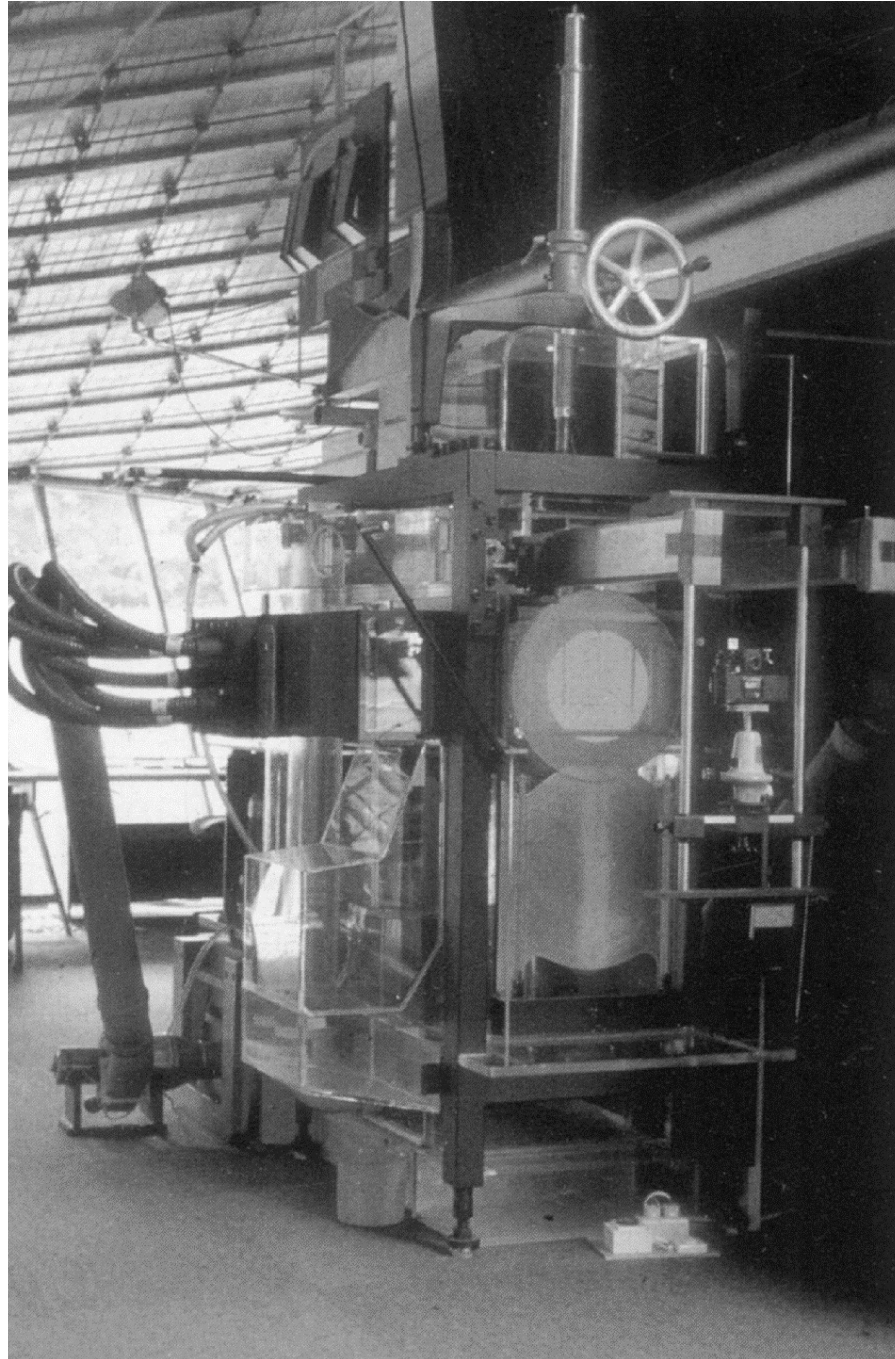

Frei Otto: Seifenfilm-Maschine



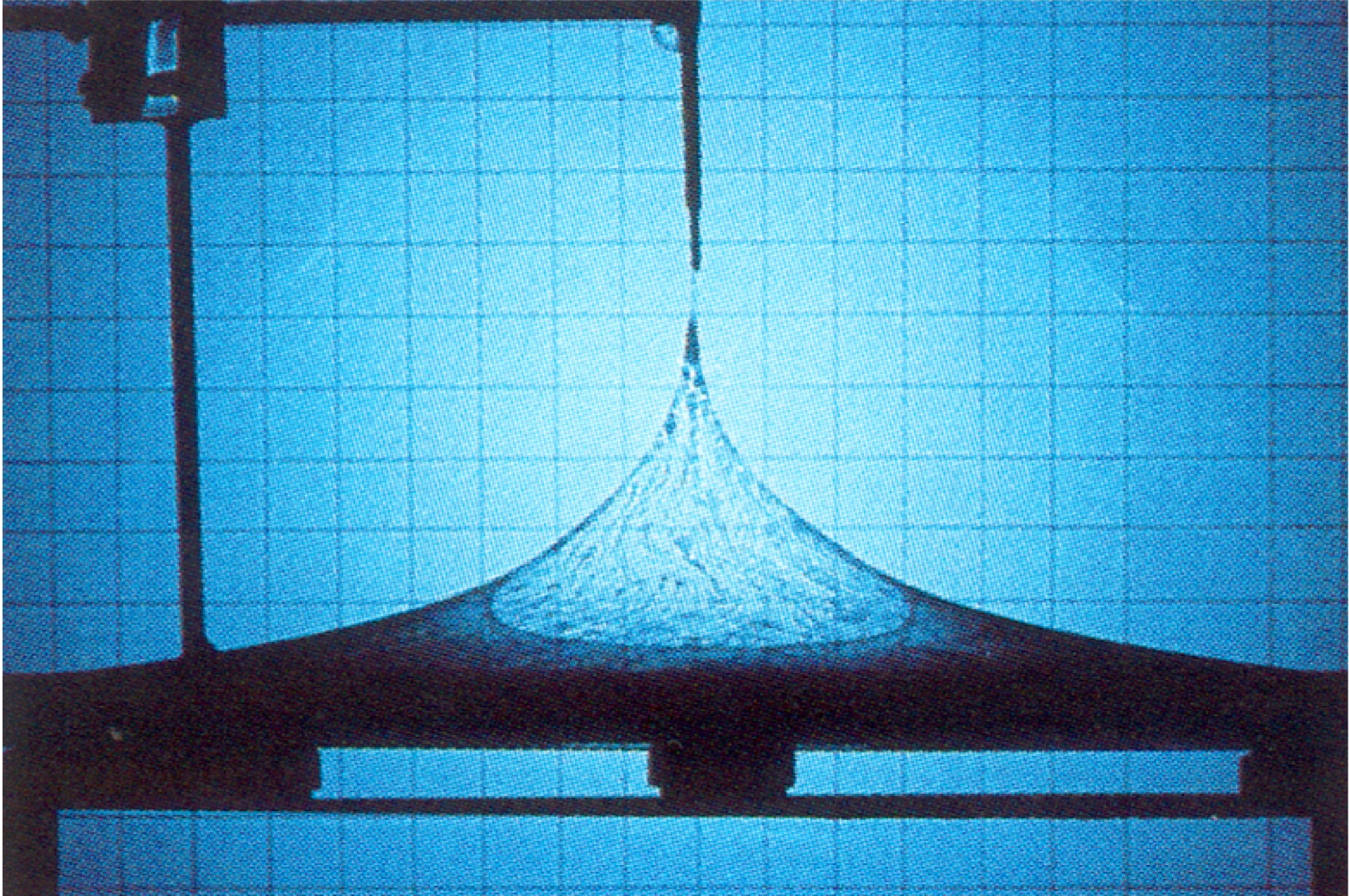



# Seilnetz- und Membranstrukturen

## *Cable-net and membrane structures*

Tragwirkung von Seilnetz- und Membranstrukturen

*Static behaviour of cable-net and membrane structures*

Frei Ottos physische Formfindungs-Experimente

*Frei Otto's physical form-finding experiments*

>>

Arten von gespannten Dachkonstruktionen

*Types of tensioned roof systems*

Pneumatische Membranstrukturen

*Pneumatic membrane structures*



*Types of tensioned roof systems*

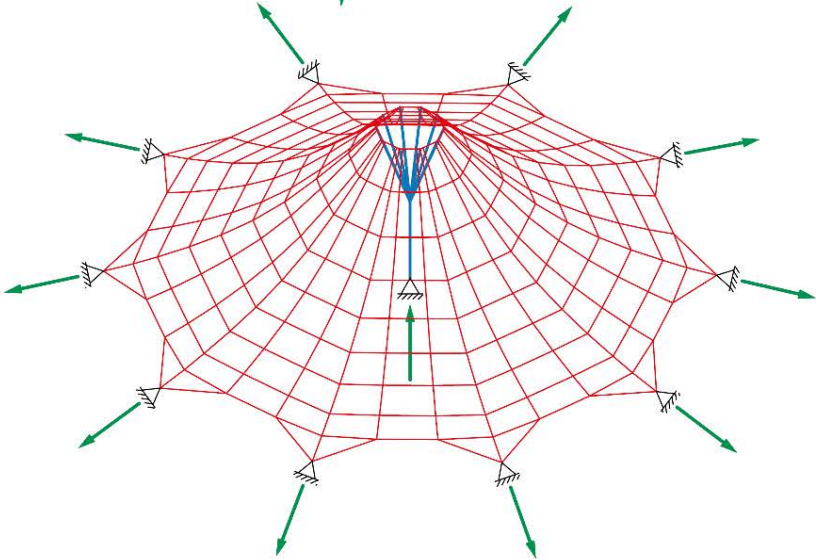
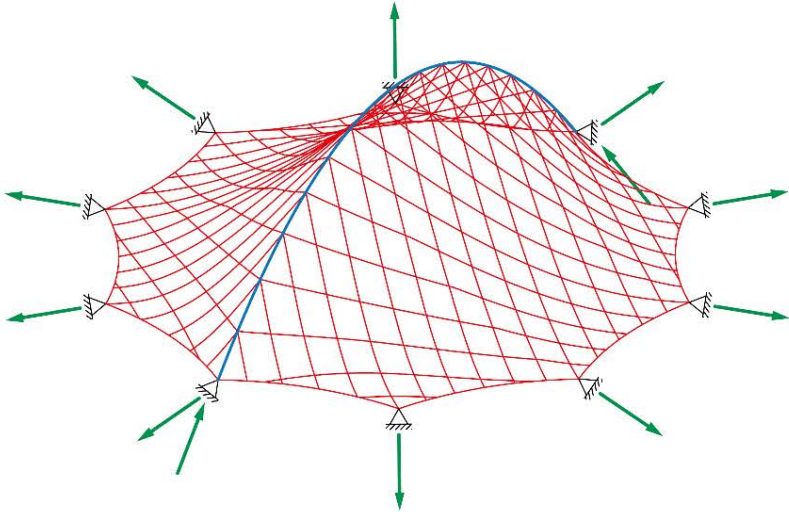
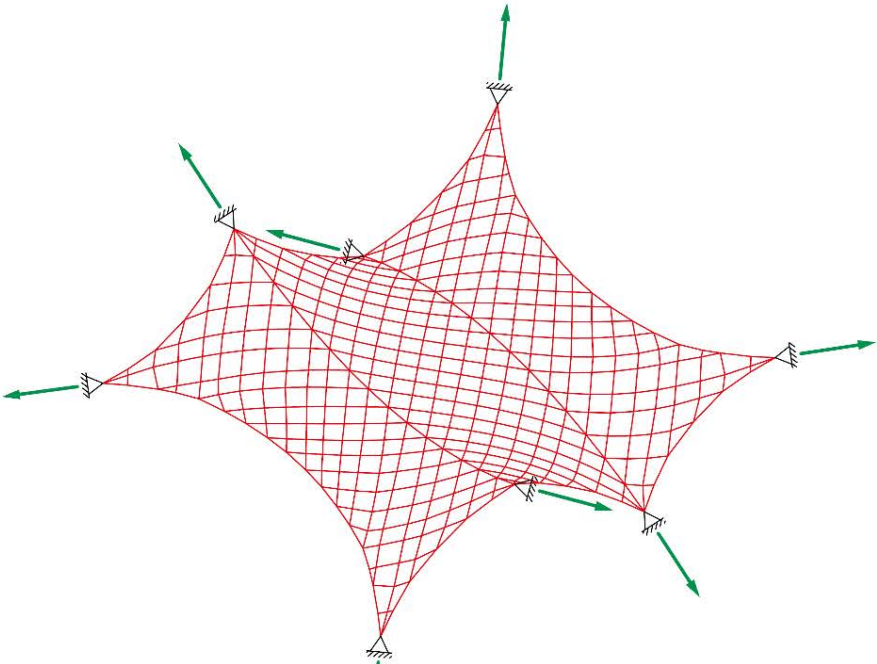
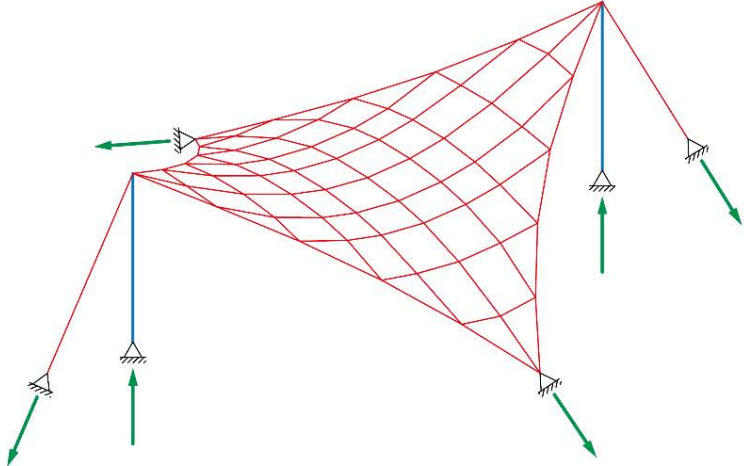

*Types of tensioned roof systems*

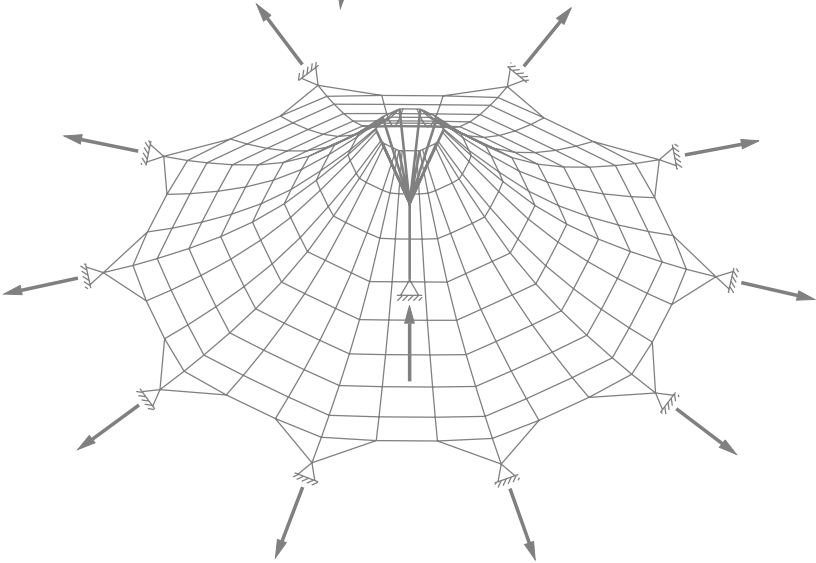
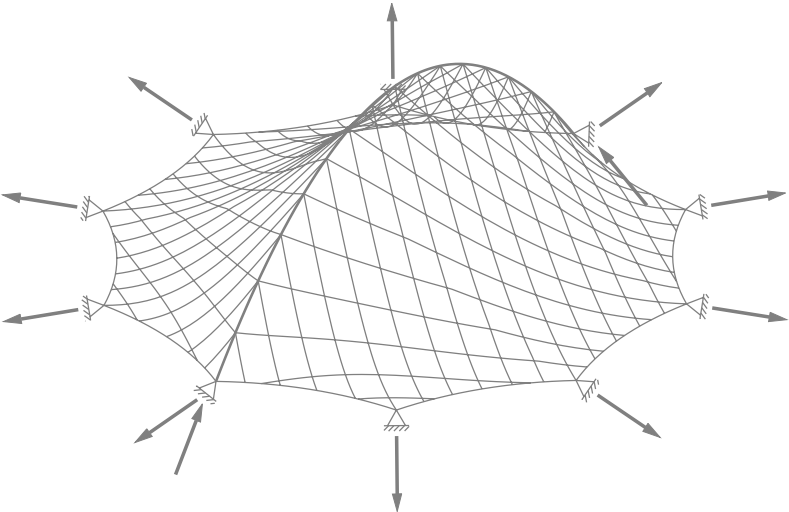
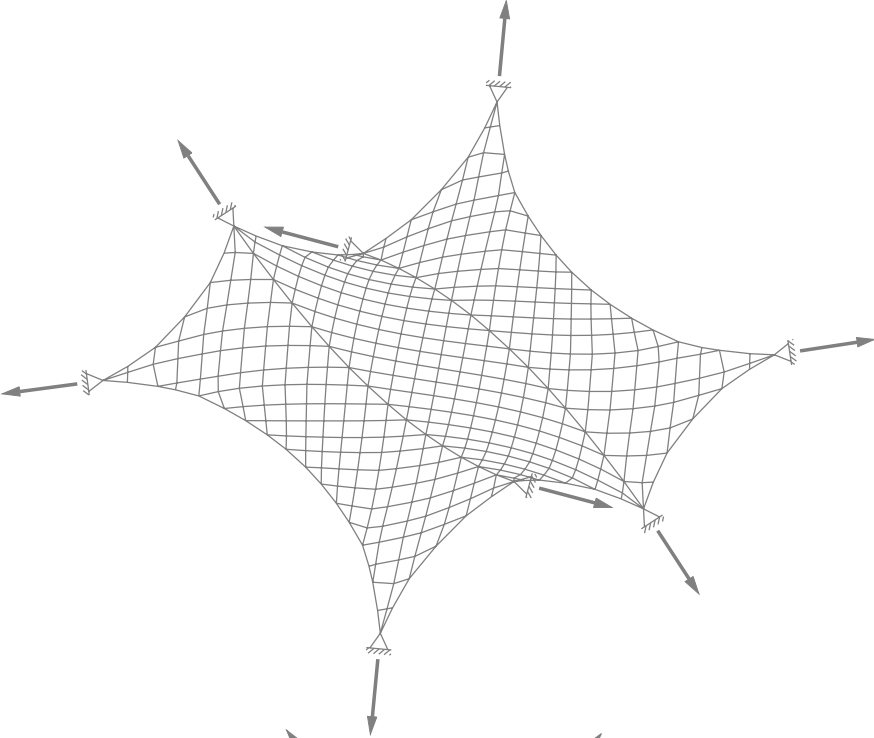
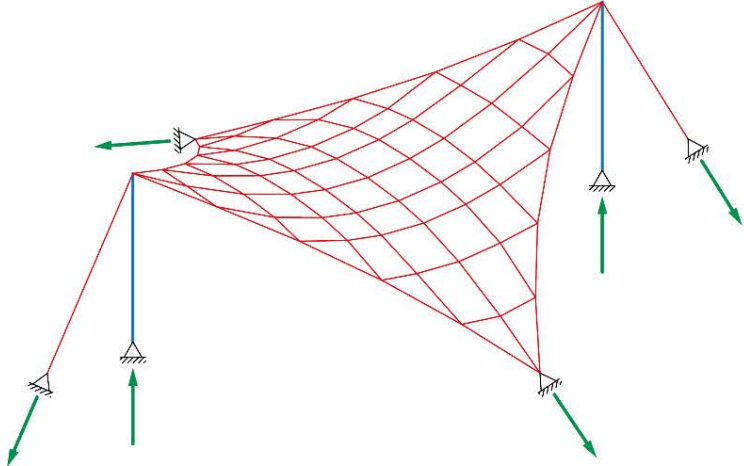

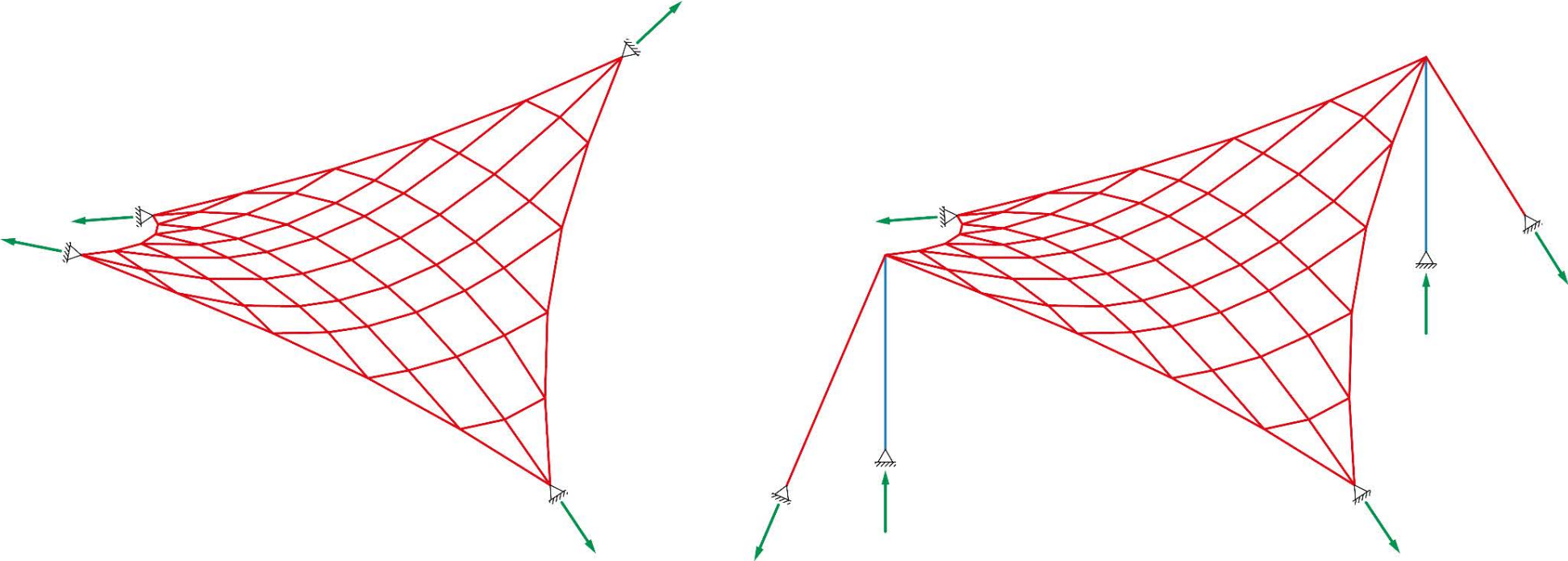





Foster + Partners, Arup: Bishop Square, London, 2005



*Types of tensioned roof systems*

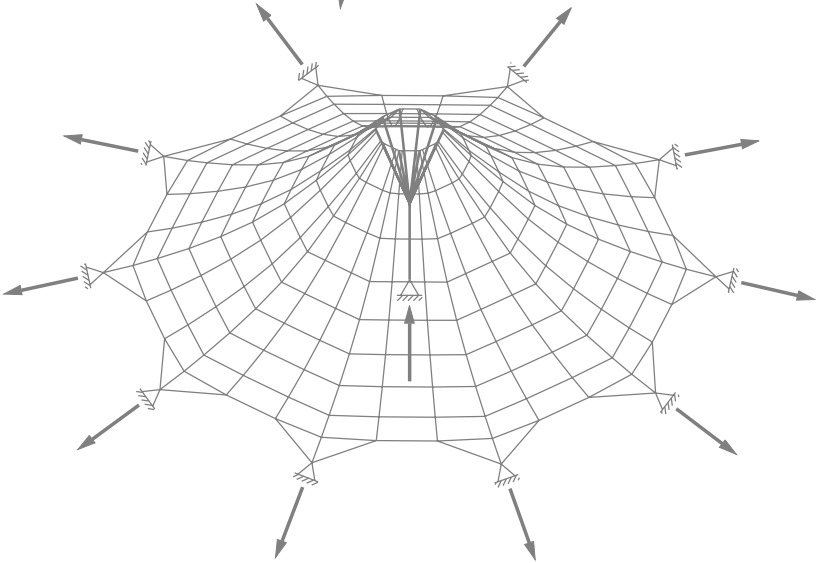
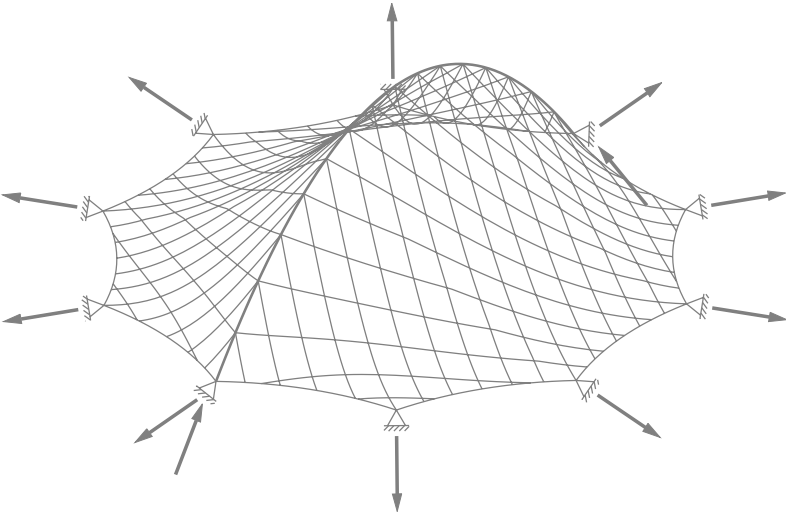
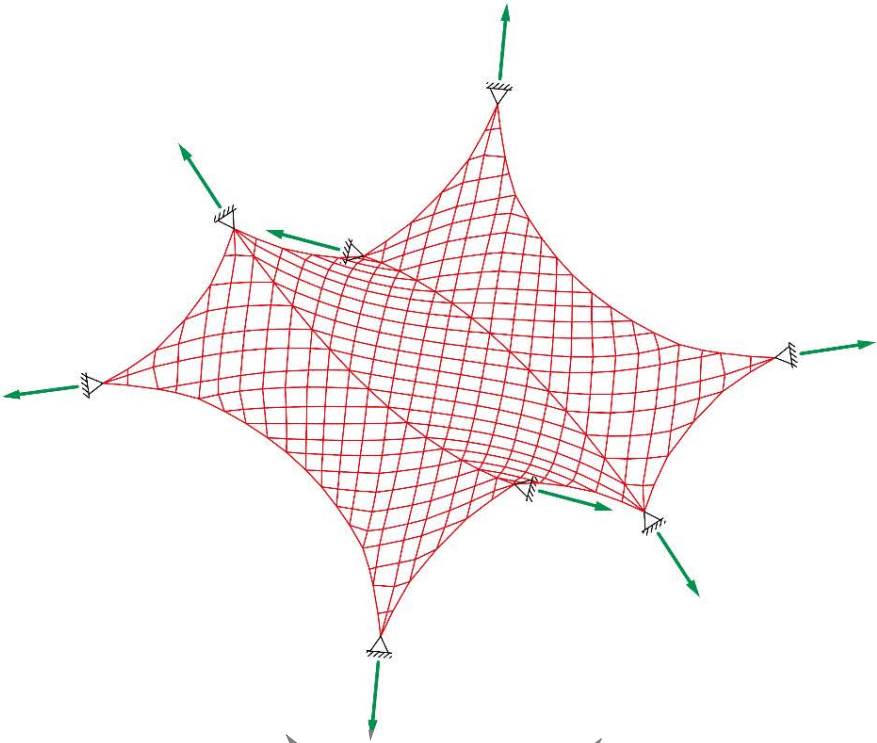
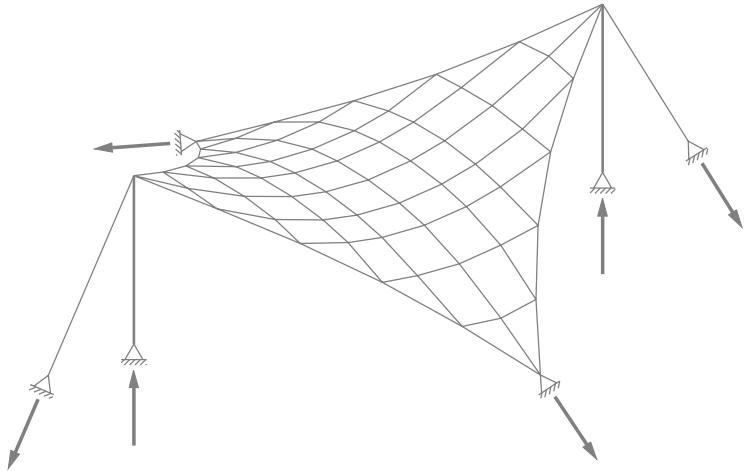





Günter Behnisch, Frei Otto: Olympisches Stadion, München, 1972



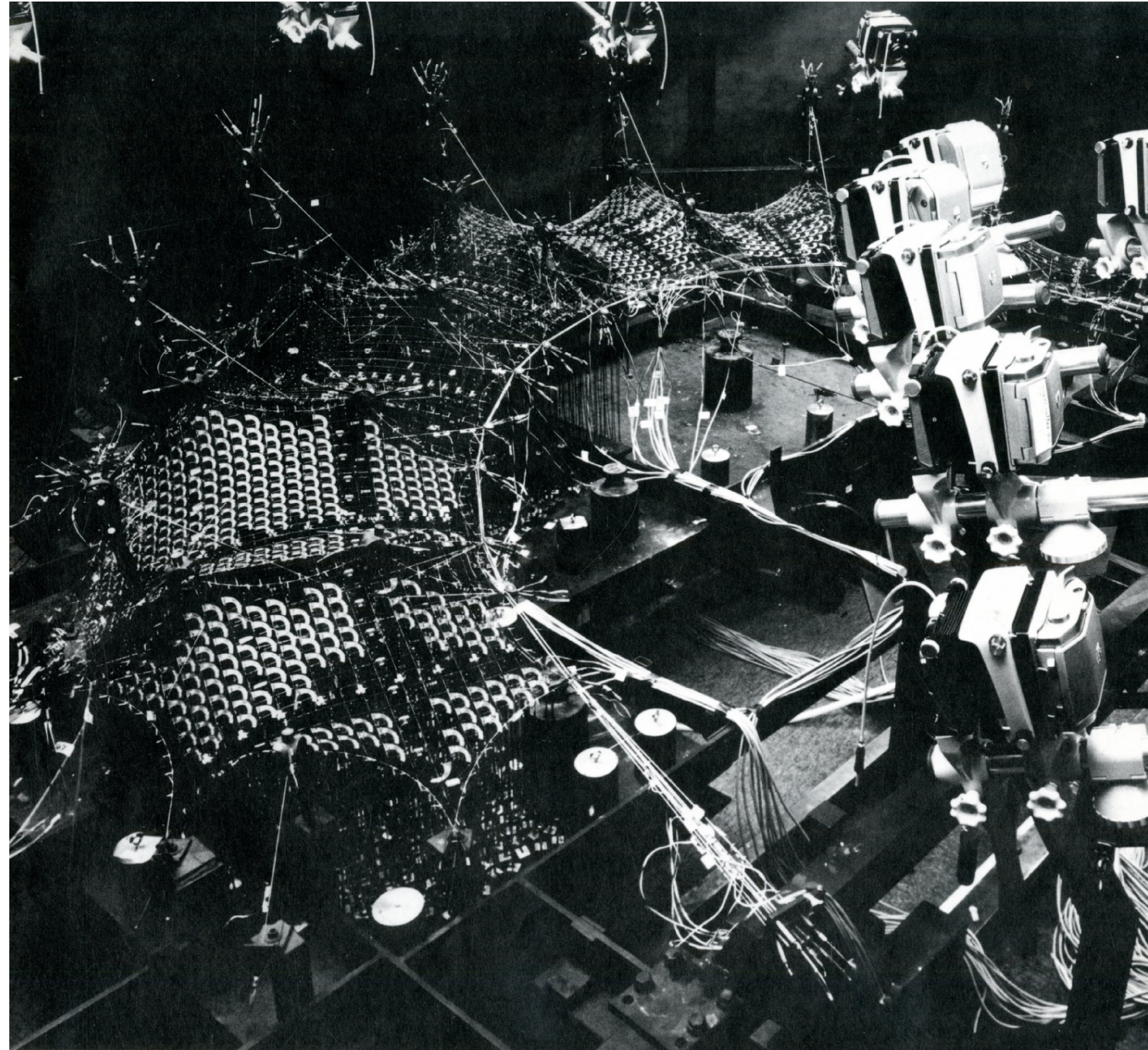

Günter Behnisch, Frei Otto: Olympisches Stadion, München, 1972





Günter Behnisch, Frei Otto: Olympisches Stadion, München, 1972





Günter Behnisch, Frei Otto: Olympisches Stadion, München, 1972





Günter Behnisch, Frei Otto: Olympisches Stadion, München, 1972

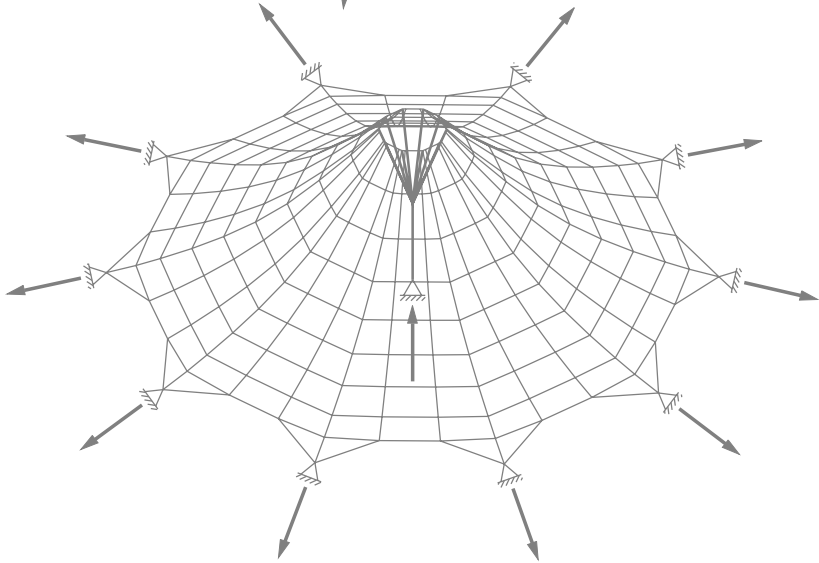
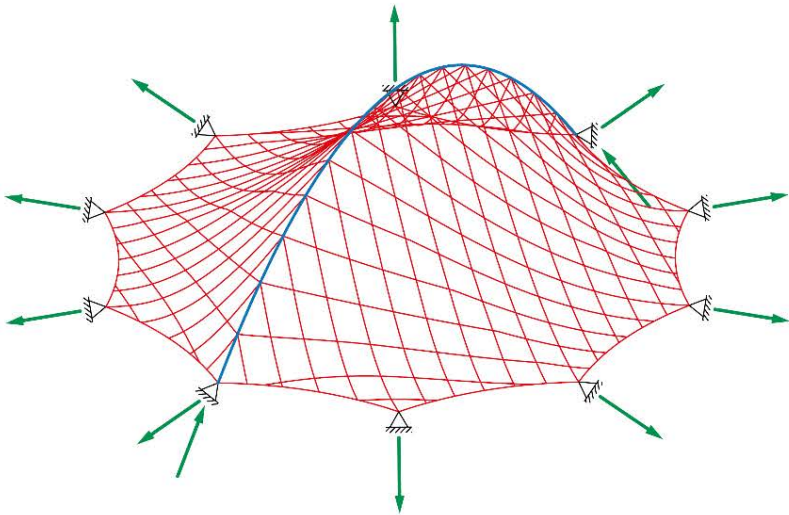
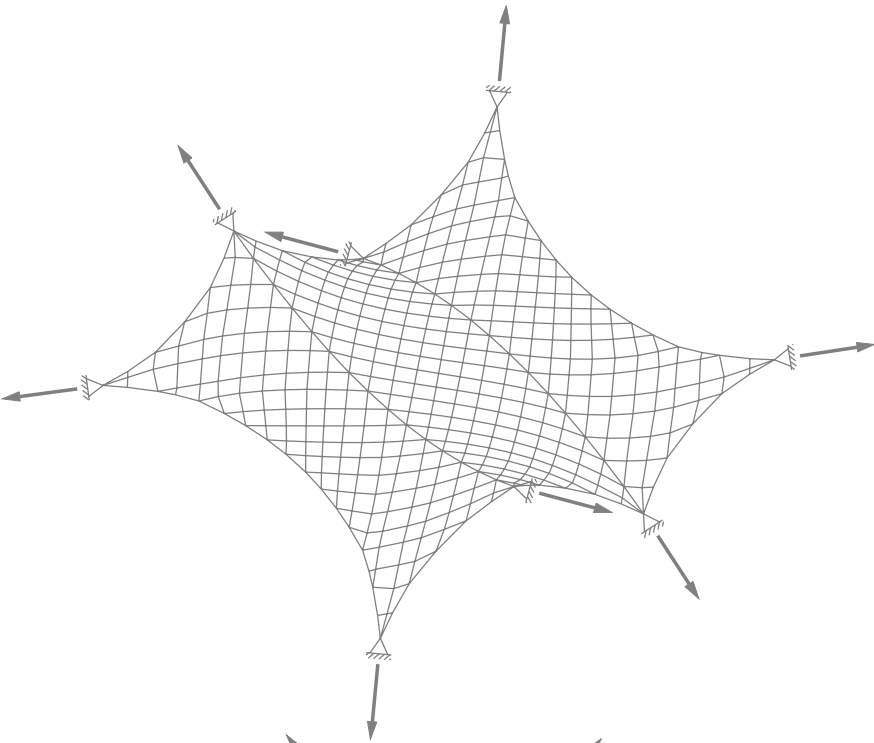
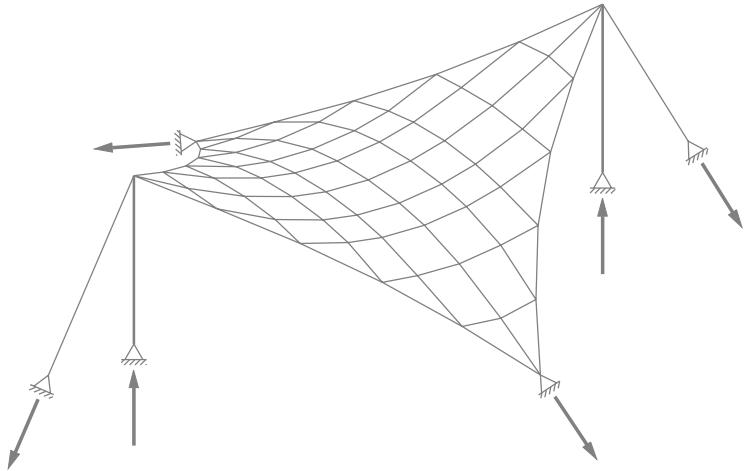





Ackermann und Partner, Schlaich Bergermann und Parter: Eishalle, München, 1983



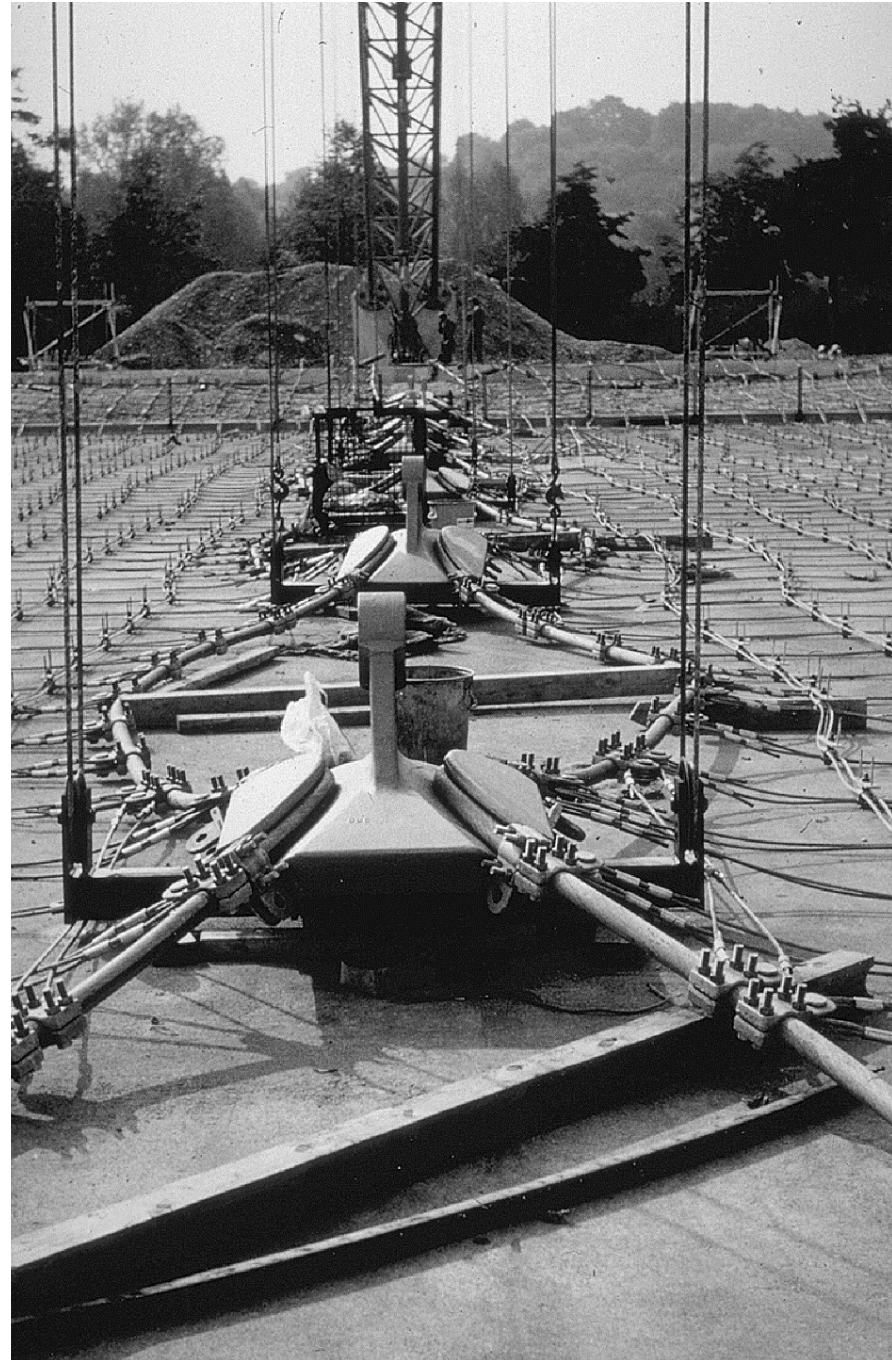

Ackermann und Partner, Schlaich Bergermann und Partner: Eishalle, München, 1983



Ackermann und Partner, Schlaich Bergermann und Parter: Eishalle, München, 1983





Ackermann und Partner, Schlaich Bergermann und Parter: Eishalle, München, 1983



*Types of tensioned roof systems*

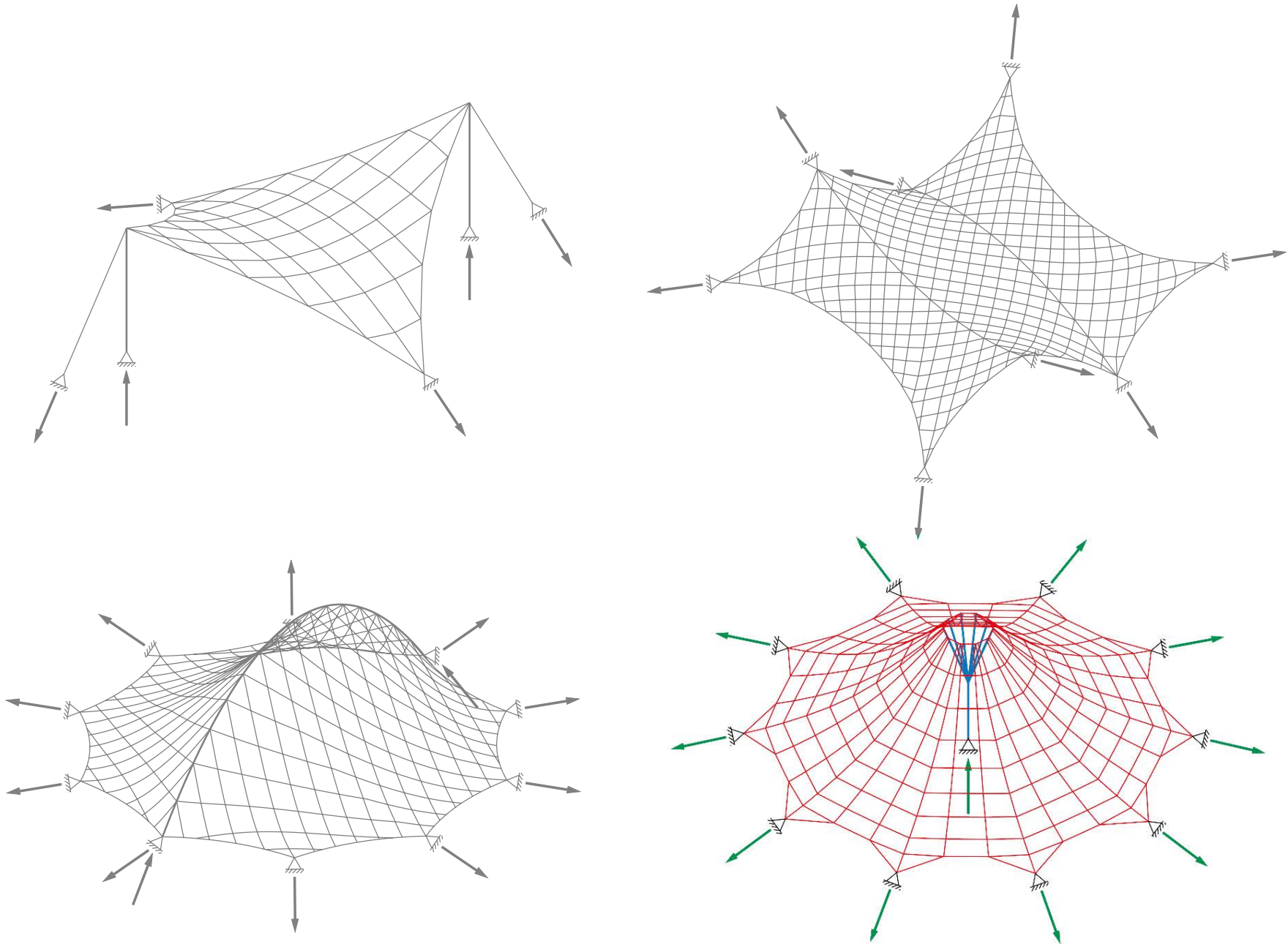





Zirkuszelt, Taupo



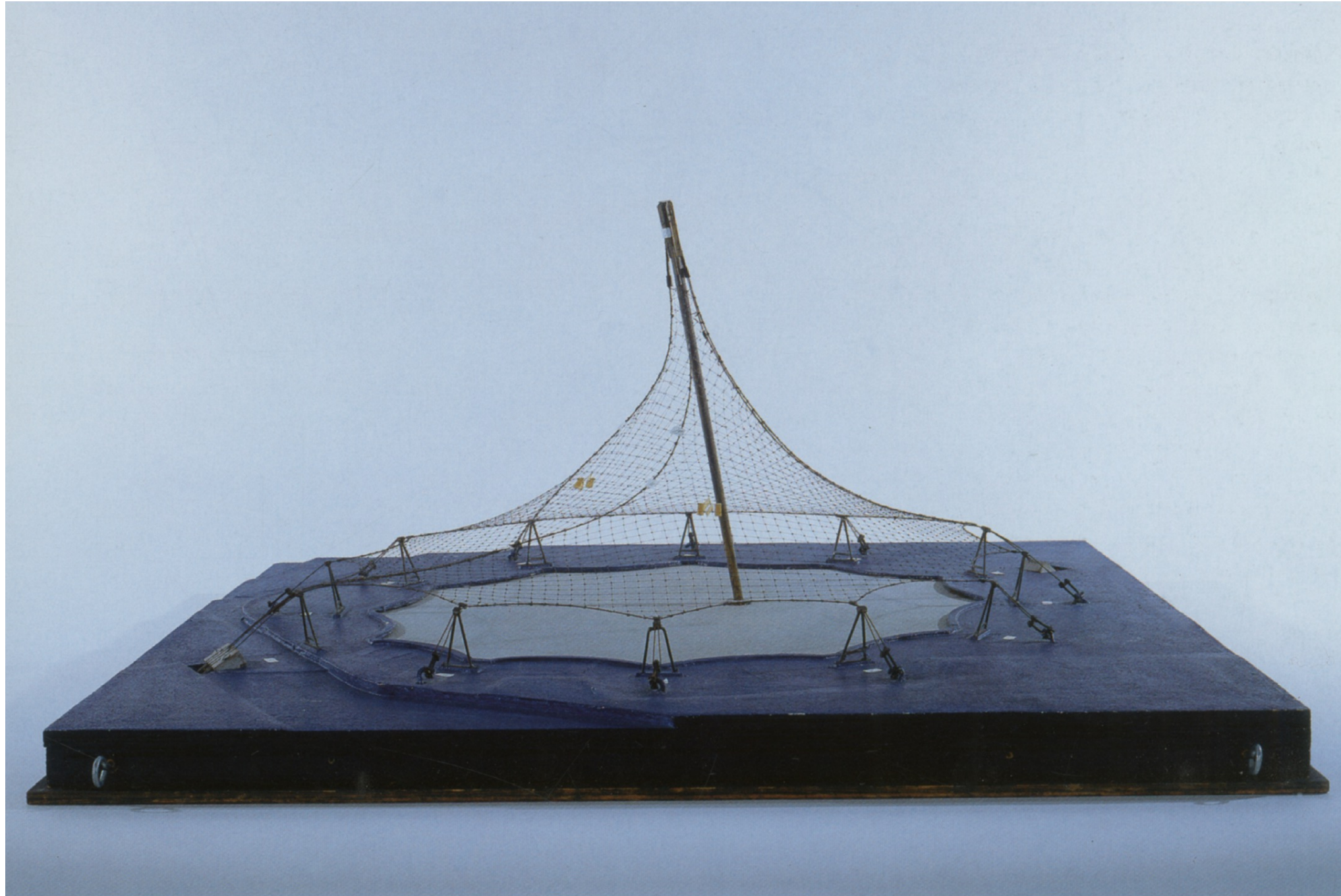

Frei Otto: Modell für das Institute for Lightweight Structures, Stuttgart, 1966





Frei Otto: Institute for Lightweight Structures, Stuttgart, 1966





Frei Otto: Institute for Lightweight Structures, Stuttgart, 1966





Frei Otto: Montreal Pavillon, Montreal, 1967



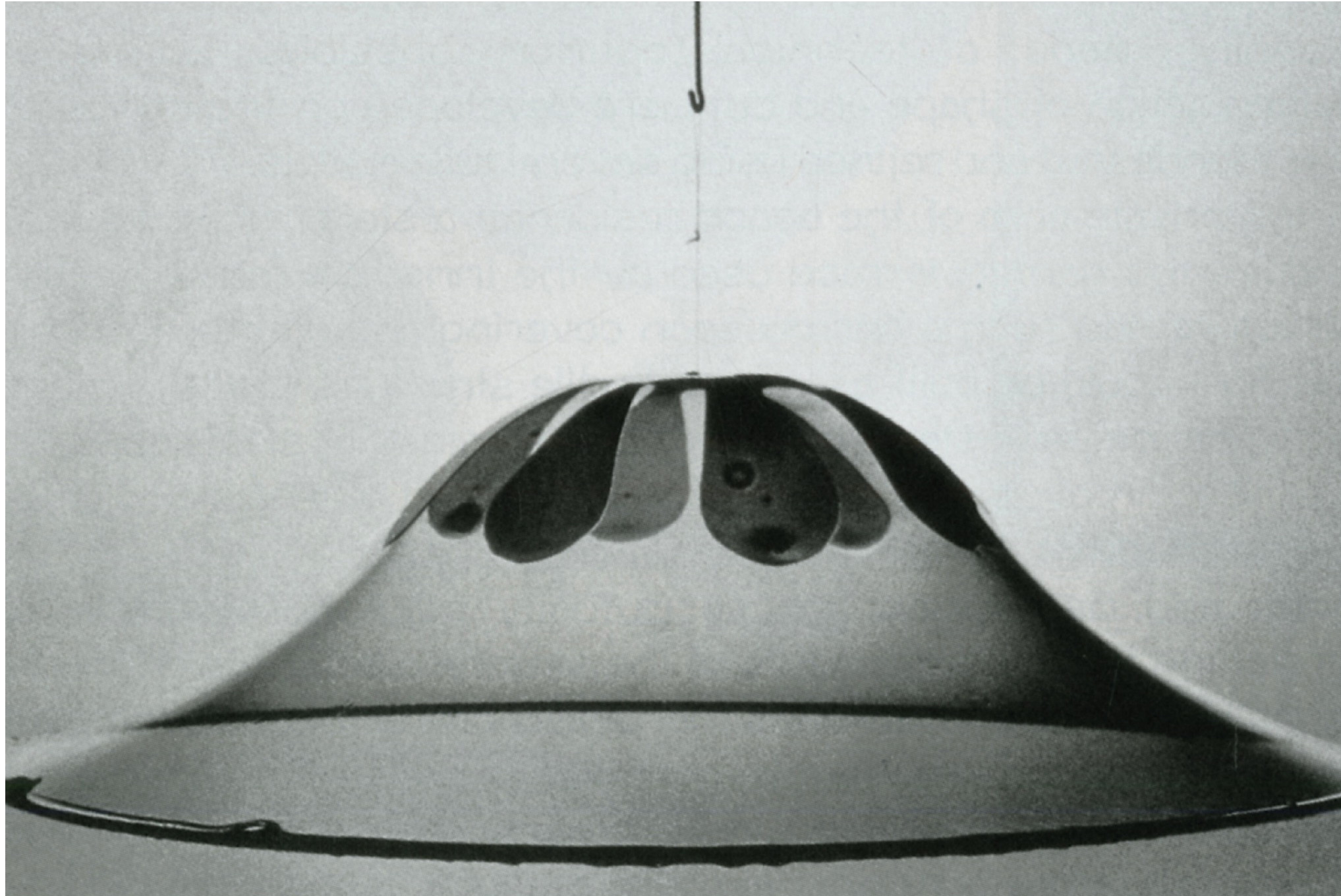

Frei Otto: Modell, Seifenfilm





Frei Otto: Buckelzelt, Aberdeen und Hyde Park, 1975





Ackermann und Partner, Schlaich Bergermann und Partner: Amt für Abfallwirtschaft, München, 1999





Ackermann und Partner, Schlaich Bergermann und Partner: Amt für Abfallwirtschaft, München, 1999



# Seilnetz- und Membranstrukturen

## *Cable-net and membrane structures*

Tragwirkung von Seilnetz- und Membranstrukturen

*Static behaviour of cable-net and membrane structures*

Frei Ottos physische Formfindungs-Experimente

*Frei Otto's physical form-finding experiments*

Arten von gespannten Dachkonstruktionen

*Types of tensioned roof systems*

>> **Pneumatische Membranstrukturen**

*Pneumatic membrane structures*



Lufthalle

*Air ball*



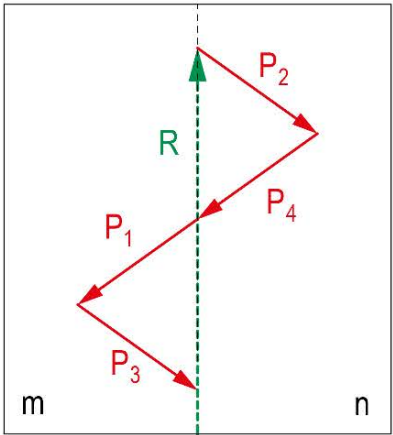
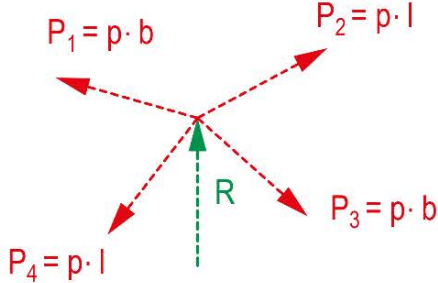
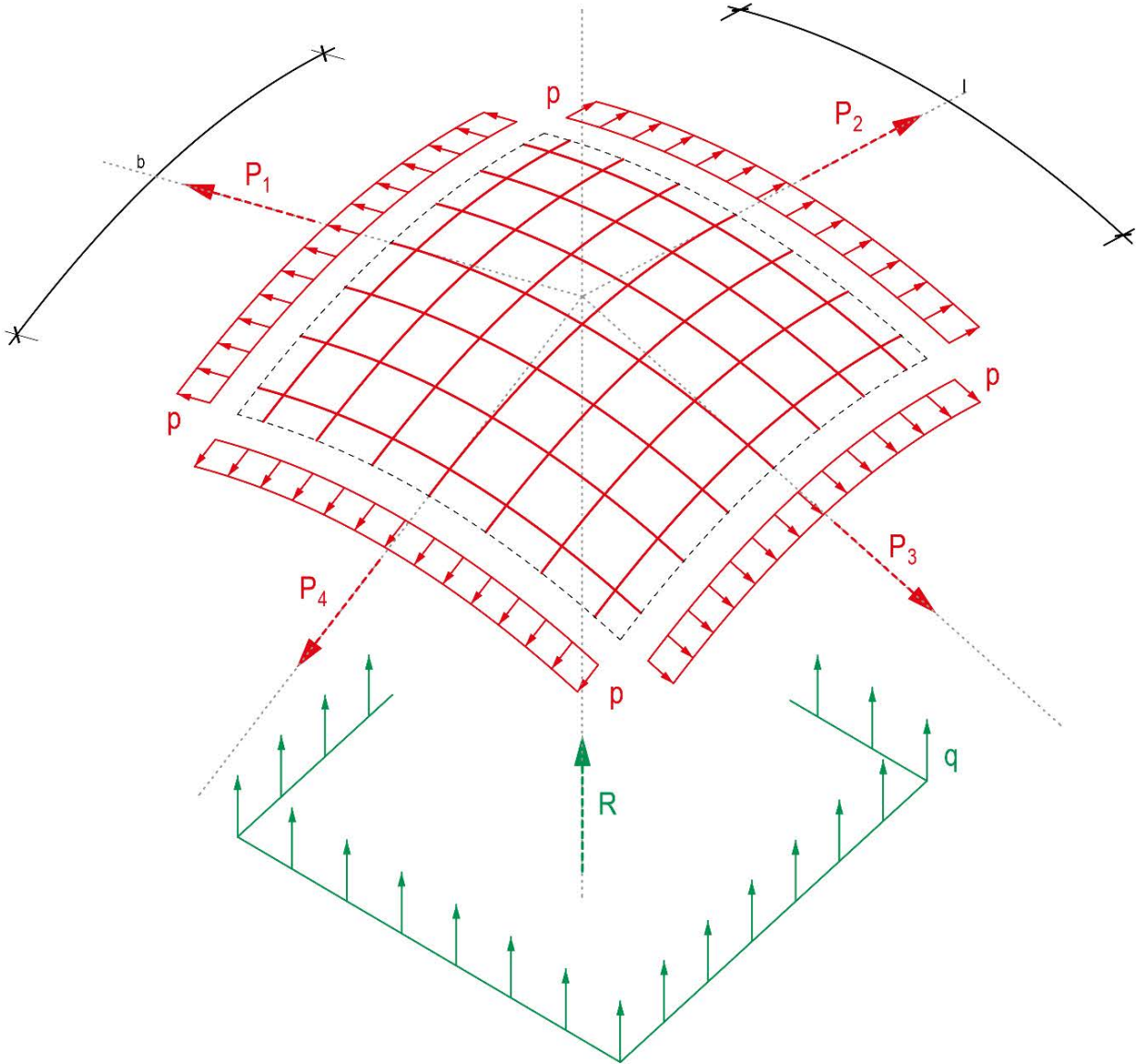





Erdstation, Raisting, Deutschland, 1964

